

Abrahams, M.J. "Movable Bridges."
Bridge Engineering Handbook.
Ed. Wai-Fah Chen and Lian Duan
Boca Raton: CRC Press, 2000

21

Movable Bridges

21.1 Introduction

21.2 Types of Movable Bridges

Bascule Bridges • Swing Spans • Vertical Lift Bridges

21.3 Structural Design

Design Criteria • Bridge Balance • Counterweights • Movable Bridge Decks • Vessel Collision • Seismic Design

21.4 Bridge Machinery

21.5 Bridge Operation, Power, and Controls

Bridge Operations • Bridge Power • Bridge Control

21.6 Traffic Control

Michael J Abrahams

Parsons Brinckerhoff Quade &
Douglas, Inc.

21.1 Introduction

Movable bridges have been an integral part of the U.S. transportation system, their development being in concert with that of (1) the development of the railroads and (2) the development of our highway system. While sometimes referred to as draw bridges, movable bridges have proved to be an economical solution to the problem of how to carry a rail line or highway across an active waterway. It is not surprising to learn that movable bridges are found most commonly in states that have low coastal zones such as California, Florida, Louisiana, and New Jersey, or a large number of inland waterways such as Michigan, Illinois, and Wisconsin.

Jurisdiction for movable bridges currently lies with the U.S. Coast Guard. In most instances, marine craft have priority, and the movable span must open to marine traffic upon demand. This precedence is reflected in the terms closed and open, used to describe the position of the movable span(s). A “closed” movable bridge has closed the waterway to marine traffic, while an “open” bridge has opened the waterway to marine traffic. Highway bridges are typically designed to remain in the closed position and only to be opened when required by marine traffic. However, movable railroad bridges can be designed to remain in either the open or closed position, depending on how frequently they are used by train traffic. The difference is important as different wind and seismic load design conditions are used to design for a bridge that is usually open vs. one that is usually closed.

The first specification for the design of movable bridges was published by the American Railway Engineering Association (AREA) in its 1922 *Manual of Railway Engineering* [1]. Until 1938 this specification was used to design both movable highway and railroad bridges, when the American Association of State Highway Officials published its *Standard Specifications for Movable Highway Bridges* [2]. Both specifications are very similar, but have remained separate. Today, movable railroad bridges are designed in accordance with the AREA Manual, Chapter 15, Part 6 [3], and movable

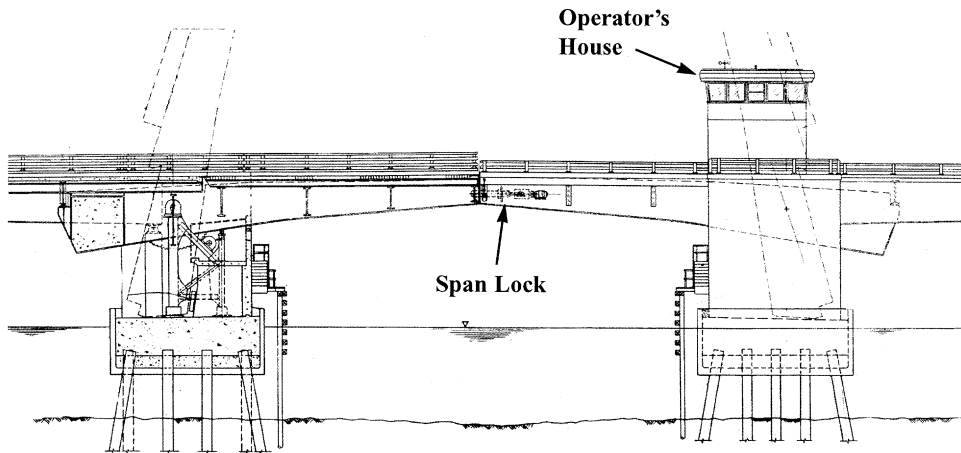

FIGURE 21.1 South Slough (Charleston) Bridge, Coos County, Oregon.

highway bridges are designed in accordance with the American Association of State Highway and Transportation Officials (AASHTO) *Standard Specifications for Movable Highway Bridges* [4]. These specifications primarily cover the mechanical and electrical aspects of a movable bridge; the structural design of the bridge is covered in other parts of the AREA Manual for railroad bridges or the AASHTO *Standard Specifications for Highway Bridges* [5].

21.2 Types of Movable Bridges

The three major categories of movable bridges are swing, bascule, and vertical lift. This list is not exclusive and there are other types, such as jackknife, reticulated, retracting, and floating that are not common and will not be described here. However, the reader should be aware that movable bridges can be crafted to suit specific site needs and are not restricted to the types discussed below.

21.2.1 Bascule Bridges

Bascule bridges are related to medieval drawbridges that protected castles and are familiar illustrations in schoolbooks. The function is the same; the bascule span leaf (or leaves if there are two) rotates from the horizontal (closed) position to the vertical (open) position to allow use of the waterway below. [Figure 21.1](#) illustrates a typical double-leaf deck-girder bascule bridge, the South Slough (Charleston) Bridge, Coos County, Oregon, which spans 126 ft (38.4 m) between trunnions.

This highway bridge includes a number of features. It is a trunnion type as the bascule span rotates about a trunnion. The counterweight, which is at the back end of the leaf and serves to balance the leaf about the trunnion, is placed outside of the pier so that it is exposed. This is advantageous in that it minimizes the width of the pier. Also note that the tail or back end of the leaf reacts against the flanking span to stop the span and to resist uplift when there is traffic (live load) on the span. There is a lock bar mechanism between the two leaves that transfers live-load shear between the leaves as the live load moves from one leaf to the other. The locks (also called center locks to distinguish them from end locks that are provided at the tail end of some bascule bridges) transfer shear only and allow rotation, expansion, and contraction to take place between the leaves. The bridge shown in [Figure 21.1](#) is operated mechanically, with drive machinery in each pier to raise and lower the leaves.

Another feature to note is the operator's house, also referred to as the control house. It is situated so that the operator has a clear view both up and down the roadway and waterway, which is required when the leaves are both raised and lowered. The lower levels of the operator's house typically house

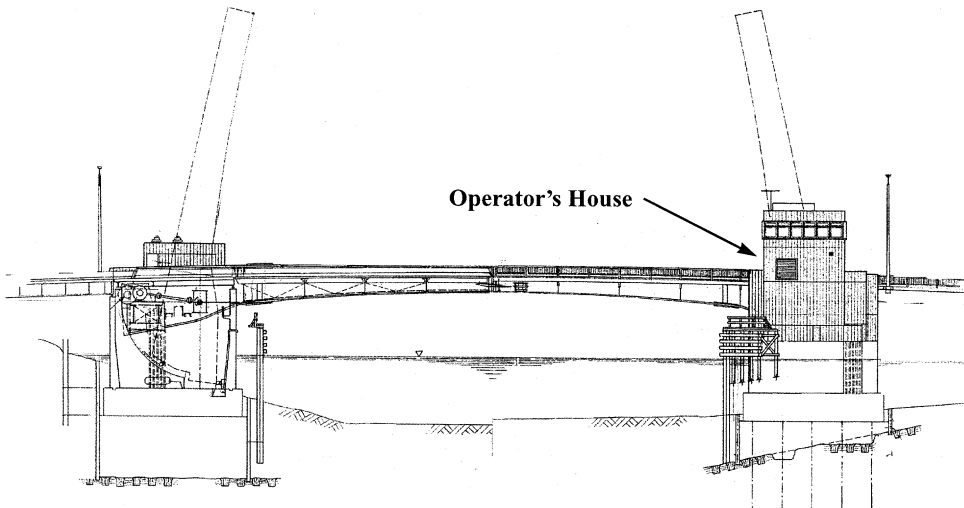

FIGURE 21.2 3rd Street Bridge, Wilmington, Delaware.

the electrical switchgear, emergency generator, bathroom, workshop, and storage space. This bridge has a free-standing fender system that is intended to guide shipping through the channel while protecting the pier from impact. Although not directly related to the bascule bridge, the use of precast footing form and tremie fill shown in the figure can be an excellent solution to constructing the pier as it minimizes the pier depth and avoids excavation at the bottom of the waterway.

Figure 21.2, the 3rd Street Bridge, Wilmington, Delaware, shows a through-girder double-leaf bascule span illustrating other typical bascule span design features. It has a center-to-center trunnion distance of 188 ft (57.3 m). For this bridge the tail or back end of the leaf, including the counterweight, is totally enclosed in the pier and the live-load reaction is located at the front wall of the pier. In addition, this bascule is shown with a mechanical drive. A larger pier is required to protect the enclosed counterweight. The advantage of an enclosed pier is that it allows the counterweight to swing below the waterline within the confines of the bascule pier pit. And, as can be seen, the bascule pier is constructed within a cofferdam. For this bridge there was not enough depth to place a full tremie seal so underwater tie-downs were used to tie the seal to the rock below. Also note the architectural detailing of the cast-in-place concrete substructure, was achieved using form liners. This was done because the bridge is located in a park and needed to be compatible with a parklike setting.

Figure 21.3, the Pelham Bay Bridge, New York, illustrates a single-leaf Scherzer rolling lift bridge or bascule railroad bridge, typical of many movable railroad bridges. The design was developed and patterned by William Scherzer in 1893 and is both simple and widely used. This is a through truss with a span of 81 ft 7 in. (24.9 m). Railroad bascule bridges are always single span, which is required by the AREA Manual, as the heavy live loads associated with heavy rail preclude a joint at midspan. This problem does not occur with light rail (trolley) live loads and combined highway/trolley double-leaf bascule bridges were frequently used in the 1920s. Also, railroad bascule bridges such as the one shown are usually through-truss spans, again due to the heavy rail live loads. This bridge has an overhead counterweight, a typical feature of Scherzer-type bridges. This allows the bridge to be placed relatively close to the water and permits a very simple pier. The track is supported by a steel girder and two simple open piers. As illustrated, the leaf rolls back on a track rather than pivoting about a trunnion. The advantage of this feature is that it is not restricted by the capacity of the trunnion shafts and it minimizes the distance between the front face of the pier and the navigation channel. As the span rotates, it rolls back away from the channel. The drive machinery is located on the moving leaf and typically uses a mechanically or hydraulically driven rack and

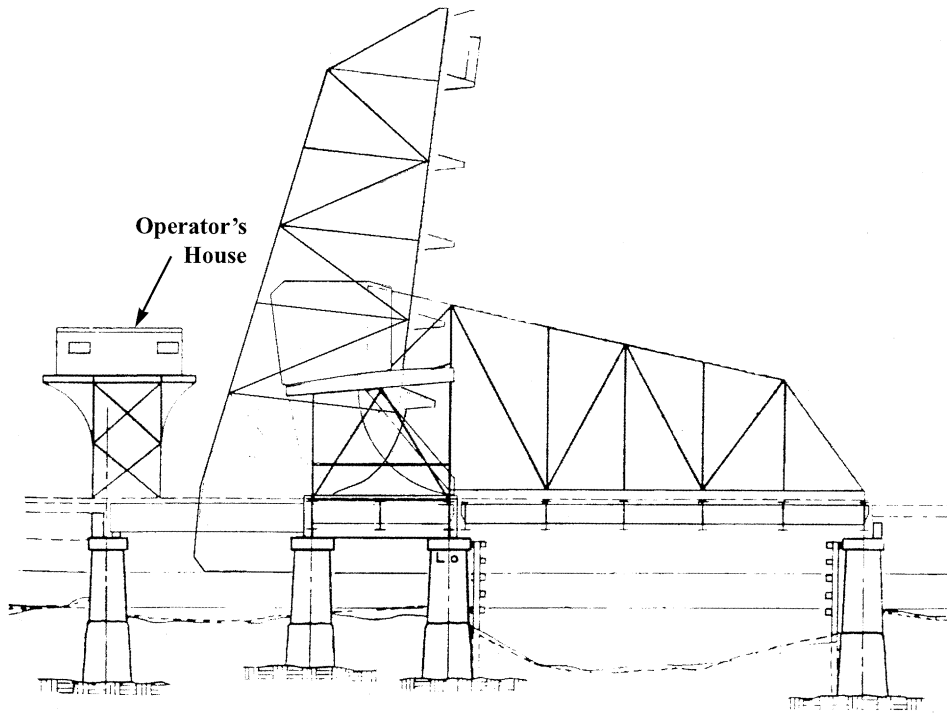

FIGURE 21.3 Pelham Bay Bridge, New York.

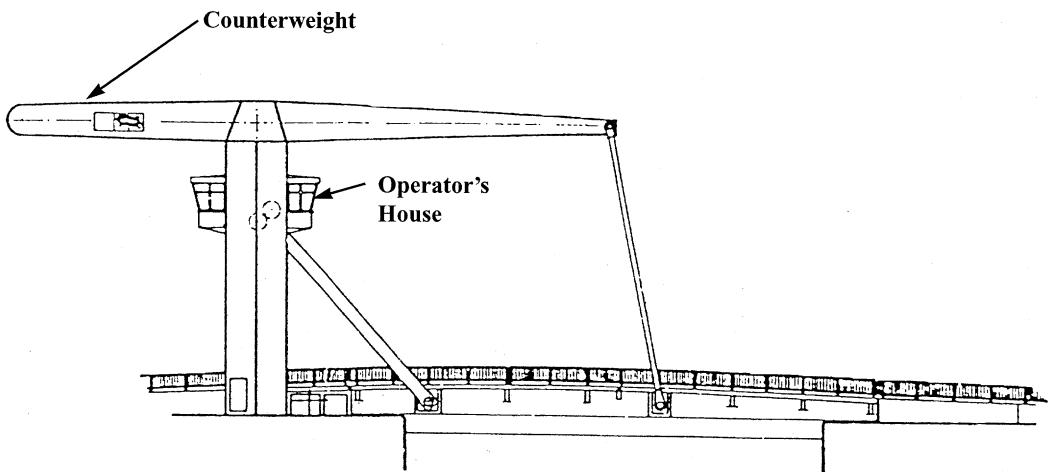

FIGURE 21.4 Manchester Road Bridge at the Canary Wharf, London.

pinion to move the span. The machinery must thus be able to operate as it rotates, and for hydraulic machinery this means the reservoir needs to be detailed accordingly. However, this is not always the case and designs have been developed that actuate the span with external, horizontally mounted hydraulic cylinders. The pier needs to be designed to accommodate the large moving load of the bascule leaf as it rolls back. Conversely, the reaction from the leaf in a trunnion-type span is concentrated in one location, simplifying the design of the pier. More-complicated bascule bridges with overhead counterweight designs have been developed where the counterweight is supported by a scissors-type frame and by trunnions that pivot.

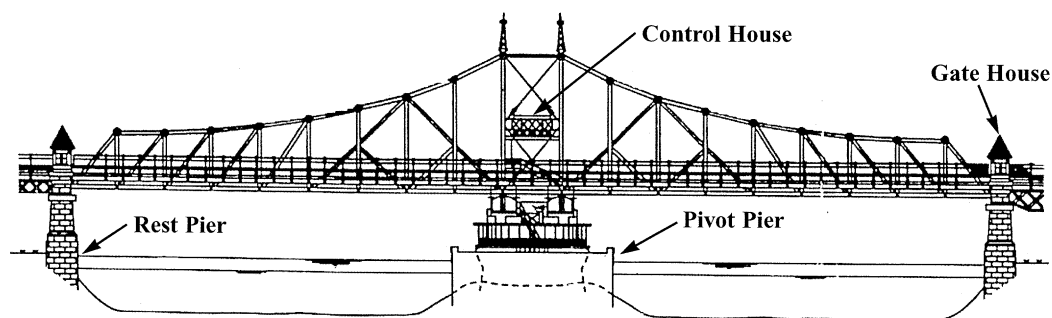

FIGURE 21.5 Macombs Dam Bridge over the Harlem River, New York City.

Figure 21.4, the Manchester Road Bridge at the Canary Wharf, London, illustrates a modern interpretation of an overhead counterweight bascule bridge. It has a span of 109 ft (33.2 m). In addition to being attractive, it is a very practical design with all of the structure above the roadway level, allowing the profile to be set as close to the waterline as desired. The design is not new and is found in many small hand-operated bridges in Holland, perhaps the most famous of which appears in Van Gogh’s 1888 painting *The Langlois Bridge*.

21.2.2 Swing Spans

Swing spans were widely used by the railroads. However, they only allowed a limited opening and the center pivot pier was often viewed as a significant impediment to navigation. The pivot pier could also require an elaborate, difficult-to-maintain, and expensive fender system. As a result, swing spans are infrequently used for movable spans. However, they can be a cost-effective solution, particularly for a double-swing span, and should be considered when evaluating options for a new movable bridge.

Figure 21.5 shows a typical through-truss swing span, the Macombs Dam Bridge over the Harlem River in New York City, constructed in 1895. This span is 415 ft (126.5 m) long. The large pivot pier in the middle of the channel illustrates the navigation issue with this design. The piers at either end of the swing span are referred to as the rest piers. By using a through truss, the depth of structure (the distance between the profile grade line and the underside of the structure) is minimized — thus minimizing the height and length of the approaches. The turning mechanism is located at the pivot pier and the entire dead load of the swing span is supported on the pivot pier. As the two arms of the swing span are equal, they are balanced. This bridge is operated with a mechanical drive that utilizes a rack-and-pinion system. There are live-load end lifts at the ends of the swing span that are engaged when the span is closed in order to allow the movable span to act as a two-span continuous bridge under live load. The end lifts, as the name suggests, lift the ends of the swing span, which are free cantilevers when the span operates. The operator’s house is typically located on the swing span within the truss but above the roadway, as this location provides good visibility. On older bridges one may also find tenders’ houses located at the ends of the swing span. These were for gate tenders who would stop traffic, manually close the traffic gates, and hold horses if necessary. The tenders have been replaced with automatic traffic signals and gates but, on this bridge, their houses remain.

Figure 21.6, the Potato Slough Bridge, San Joaquin County, California, illustrates a good example of a modern highway swing span. This bridge has a 310-ft (94.5-m) swing span that uses simple composite deck, steel girder construction. It is very economical on a square foot basis compared with a bascule or vertical lift bridge, due to its simplicity and lack of a large counterweight. One way of looking at this is that on a bascule or vertical lift bridge a large amount of structure is composed of the counterweight and its supports. These elements do not contribute to effective load-carrying area. The swing span back span, on the other hand, not only acts as a counterweight

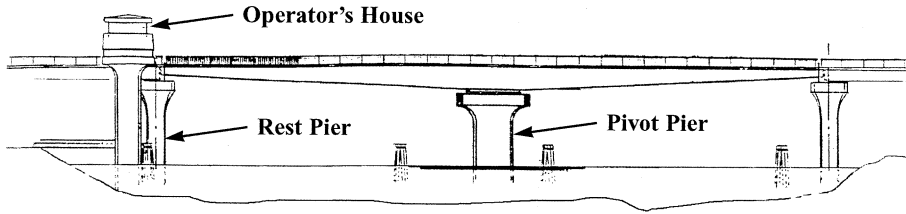

FIGURE 21.6 Potato Slough Bridge, San Joaquin County, California.

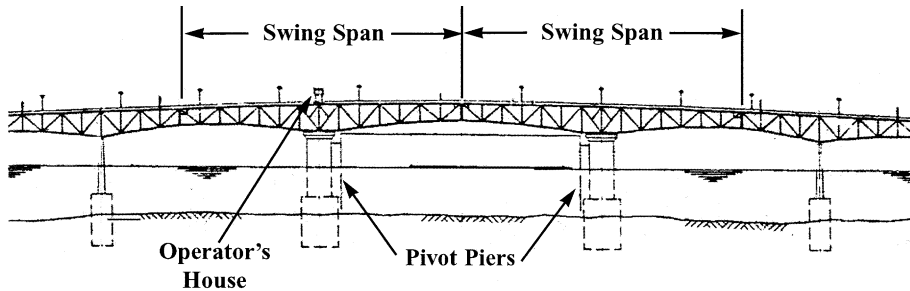

FIGURE 21.7 Coleman Bridge over the York River, Virginia.

but also carries traffic making for a more cost-effective solution. One disadvantage of the deck girder design is that it does not minimize the depth of construction, as does a through-truss or through-girder design. On this bridge the swing span is symmetrical and thus balanced. Nevertheless, some small counterweights may be required to correct any transverse imbalance. The operator's house is located in an adjacent independent structure, again in an area that provides good visibility upstream, downstream, and along the roadway. The pivot pier can accommodate switchgear and a generator. The roadway joints at the ends of the span are on a radius. These could also be detailed as beveled joints, provided that the span only needs to swing in one direction. However, some designers believe it is preferable to design a swing bridge to swing in either direction to allow the bridge to be opened away from oncoming marine traffic and to minimize damage if the structure is struck and needs to swing free.

Figure 21.7 illustrates the double-swing span Coleman Bridge across the York River in Virginia. The two swing spans are each 500 ft (152.4 m) long and provide a 420-ft (128.0-m) wide navigation channel, wide enough to accommodate the range of U.S. Navy vessels that traverse the opening. The bridge is a double-swing deck truss. At this site the river banks are relatively high, so the depth of structure was not a significant issue. Because the bridge is located adjacent to a national park, the low profile of a deck truss was a major advantage. The bridge uses hydraulic motors to drive the span, driving through a rack-and-pinion system similar to that used in large slewing excavators. Unlike the single-swing bridges above, there are lock bars at all three movable span joints. These are driven when the span is in the closed position and function in the same manner as lock bars between the leaves of a double-leaf bascule. There are wedges at each pivot pier to support the live load. As shown, the operator's house is located above one of the swing spans. The control equipment is located inside the operator's house and the generator and switchgear is located on the swing spans below deck. This bridge superstructure was replaced in 1996 and uses a lightweight concrete deck. The piers were constructed in 1952 when the bridge was first built using concrete-filled steel shell caissons that were placed by dredging through open wells.

Figure 21.8, the Tchefuncte River Bridge, Madisonville, Louisiana illustrates a bobtail swing, which is used where only a small channel is required. The structure is a through girder (this minimizes the depth of construction) with a main span of 160 ft (48.8 m). The 80-ft (24.4 m) long

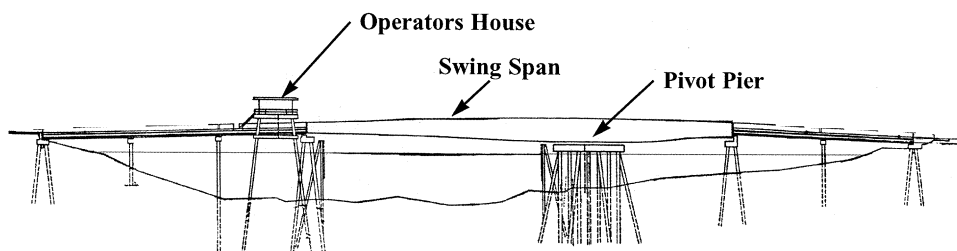

FIGURE 21.8 Tchefuncte River Bridge, Madisonville, Louisiana.

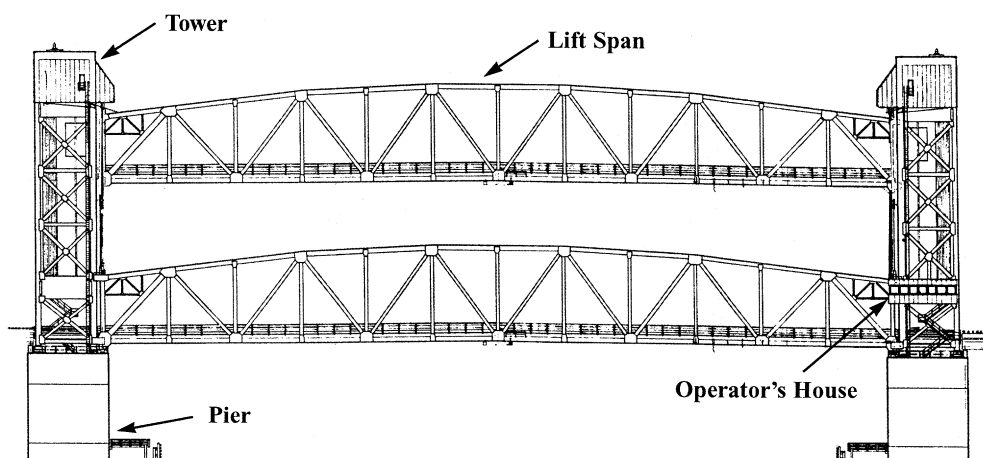

FIGURE 21.9 James River Bridge, Virginia.

bobtail end contains a concrete counterweight that balances the weight of the longer front span. This type of design is particularly well suited where the profile is near the waterline. A relatively simple foundation can support the swing span and no structure is required above deck level. This bridge is operated using hydraulic cylinders on the pivot pier. Girder swing spans tend to be flexible and need a wedge or end lift system that can lift the ends of the span and provide a live-load support when it is in the closed position.

21.2.3 Vertical Lift Bridges

Vertical lift bridges, the last of the three major types of movable bridges, are most suitable for longer spans, particularly for railroad bridges.

Figure 21.9 shows a through-truss highway lift span — the James River Bridge in Virginia — which has a span of 415 ft (126.5 m). The maximum span for this type of design to date is approximately 550 ft (167.7 m) long. The weight of the lift span is balanced by counterweights, one in each tower. Wire ropes that pass over sheaves in the towers are attached to the lift span at one end and the counterweight at the other. A secondary counterweight system is often required to balance the weight of the wire ropes as the span moves up and down and the weight of the wire ropes shifts from one side of the sheaves to the other.

Two types of drive systems are commonly employed, tower drive and span drive. A span drive places the drive machinery in the center of the lift span and, through drive shafts, operates a winch and hauling rope system to raise and lower the span. A tower drive — as the name implies — uses drive machinery in each tower to operate the span. The advantage of the span drive is that it ensures that the two ends lift together, whereas a tower drive requires coordinating the movement

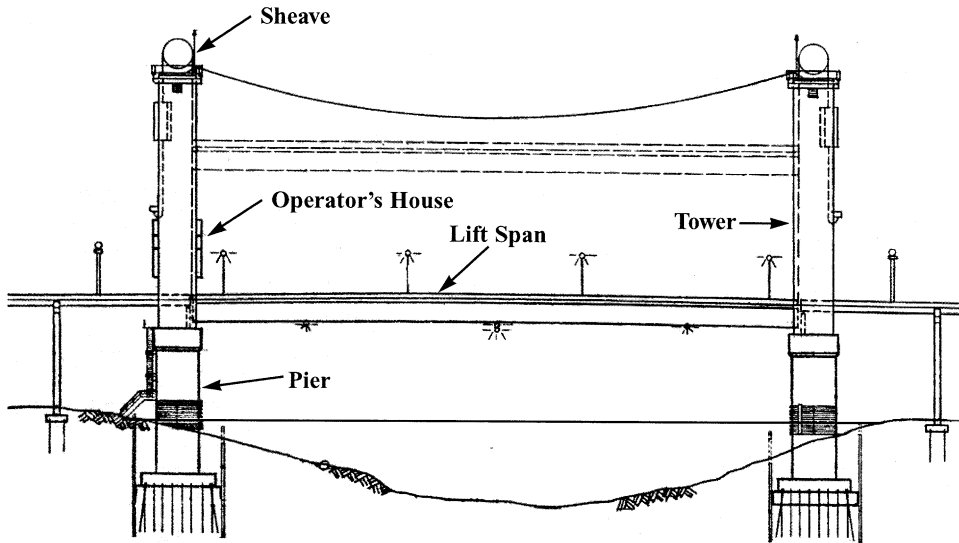

FIGURE 21.10 Danziger Bridge, New Orleans, Louisiana.

at each end. The disadvantages of the span drive are that it tends to be ugly and the lift span, ropes, sheaves, and counterweights must carry the additional weight of the operating machinery. Consequently, tower drives are favored on new bridges.

The machinery drive can be either mechanical or hydraulic. Guide wheels guide the span as it moves along the tower legs, and they must be detailed so as to allow expansion and contraction at one end of the lift span to accommodate changes in temperature. Span locks are used at each end of the lift span to ensure that it does not drift up when in the down (closed) position. If the bridge is normally in the open position, an additional set of span locks needs to be provided. As shown, the operator's house is located on one of the towers. For this bridge, the house partially wraps around the tower to provide good visibility of both the waterway and roadway.

Figure 21.10, the Danziger Bridge, New Orleans, is a vertical lift bridge that uses an orthotropic deck with steel box girders for the lift span and welded steel boxes for the tower. The lift span is 320 ft (97.6 m) long. While the depth of construction is greater than that of an equivalent through truss, the appearance is cleaner, the load to lift should be less and the height of the towers lower than that of an equivalent through truss. The foundations for both of these vertical lift bridges used deep cofferdam construction, which may be advantageous for longer spans because the mass and rigidity of such a foundation should be better able to resist the forces from collision with a large ship.

21.3 Structural Design

21.3.1 Design Criteria

In the closed positions movable bridges are designed for the same design conditions as fixed bridges. However, a movable bridge must also be designed for the following conditions. The load combinations described below are from the AASHTO Specifications [4], and are based on allowable stresses. Similar provisions apply to railroad bridges.

1. *Impact Loads:* Dead load plus 20%. This is applied to structural parts in which the member stress varies with the movement of the span. It is not combined with live-load stresses. For structural parts with stresses caused by machinery or forces applied for moving or stopping the span, 100% impact is used. For end floorbeams, live load plus 100% impact is used.

2. *Wind Loads*:
 - a. Movable Span Closed:
 - i. Structure to be designed as a fixed span.
 - b. Movable Span Open:
 - ii. When the movable span is normally left in the closed position, the structure is designed for 30 pounds per square foot (psf) (1.436 kPa) wind load on the structure, combined with dead load, and 20% of dead load to allow for impact, at 1.25 times the allowable unit stresses. For swing bridges, the design is also checked for 30 psf (1.436 kPa) wind load on one arm and 20 psf (0.958 kPa) wind load on the other arm.
 - iii. When the movable span is normally left in the open position, the structure is designed for 50 psf (2.394 kPa) wind load on the structure, combined with dead load, at 1.33 times allowable unit stresses. For swing bridges the design is also checked for 50 psf (2.394 kPa) wind load on one arm and 35 psf (1.676 kPa) wind load on the other arm, applied simultaneously).
3. *Ice/Snow Loads*: These are typically not considered in structural design but must be considered in designing the operating machinery.
4. *Bascule Bridges*: The stresses in the main and counterweight trusses or girders are checked for the following load cases:
 - a. Case I Dead load: Bridge open in any position
 - b. Case II Dead load: Bridge closed
 - c. Case III Dead load. Bridge closed with counterweights independently supported
 - d. Case IV Live load plus impact: Bridge closed with live loads thereon
5. *Swing Bridges*: The main trusses or girders are checked for the following load cases:
 - a. Case I Dead load: Bridge open, or closed with end wedges (lifts) not driven
 - b. Case II Dead load: Bridge closed, with its wedges lifted to give positive end reaction, equal to the reaction due to temperature plus 1.5 times the maximum negative reaction of the live load and impact, or the force required to lift the span 1 in. (25 mm) whichever is the greater
 - c. Case III Live load plus impact: Bridge closed, with one arm loaded and considered as a simple span, but with end wedges (lifts) not driven
 - d. Case IV Live load plus impact: Bridge closed and considered as a continuous structure
6. *Vertical Lift Bridges*: The main trusses or girders and towers are checked for the following load cases:
 - a. Case I Dead load: Bridge open
 - b. Case II Dead load: Bridge closed
 - c. Case III Dead load with bridge closed and counterweights independently supported (it should be noted that vertical lift bridges need to include provisions to support the counterweights independently)
 - d. Case IV. Bridge closed with live loads thereon

All of the above applies to the structural design of the moving span and its supports. For design of the operating machinery, there are other load cases contained in the AREA Manual [3] and the AASHTO Specifications [4].

21.3.2 Bridge Balance

Almost all movable bridges are counterweighted so that the machinery that moves the span only needs to overcome inertia, friction, wind, ice, and imbalance. It is prudent to design bridges with a healthy allowance for imbalance as the as-built conditions are never perfect, particularly over time. Recently, at least one bascule bridge and several lift spans have been designed without counterweights, relying instead on the force of the hydraulic machinery to move the span. While this saves the cost of the counterweight

and reduces the design dead loads, one needs to compare carefully the reduced construction costs against the present value of the added machinery costs and future annual electric utility demand and service costs (utility rates are based not only on how much energy is consumed but also on how much it costs the utility to be able to supply the energy on demand).

Counterweights are designed to allow for adjustment of the bridge balance, recognizing that during its lifetime, the weight and weight distribution of the bridge can change. The typical reasons for these changes are deck replacement, paint, repairs, or new span locks, among others. Typically, contract drawings show the configuration, estimated concrete volume, and location of the counterweights, but require that the contractor be responsible for balancing the span. This is reasonable as the designer does not know the final weight of the elements to be used, such as the size of the splice plates, the lock bar machinery, concrete unit weight, and other variables. Balance checks can be made during construction or retrofit using detailed calculations accounting for every item that contributes to the weight of the moving span. These calculations need to account for the location of the weight in reference to the horizontal and vertical global axes of the span and, for an asymmetrical span such as a swing span, the transverse axis. For bascule and vertical lift bridges, current practice is to attach strain gauges to the machinery drive shafts and measure the strain in the shafts as the span is actuated through a full cycle, thereby accurately determining the balance. Strain gauge balancing was developed for trunnion bascule type bridges [6,7]. The method has been extended to rolling lift bascule bridges as well as vertical lift bridges.

21.3.3 Counterweights

Figure 21.11 illustrates the typical counterweight configuration for a vertical lift bridge. Both the AREA Manual [3] and AASHTO Specifications [4] require that a pocket be provided in the counterweight for adjustment. The pockets are then partially filled with smaller counterweight blocks, which can be moved by hand to adjust the balance of the bridge. Counterweights are typically made up of a concrete surrounding a steel frame or a reinforced steel box that is filled with normal-weight concrete. Heavyweight concrete can be used to minimize the size of the counterweight. Punchings from bolt holes can be mixed in with concrete to increase its density or concrete can be made using heavyweight aggregate, although this is seldom done due to cost considerations. However, there is at least one vertical lift bridge where cast-iron counterweights were used because the counterweights needed to be as small as possible as they were concealed in the towers. If there is not enough space left for added blocks or if there are no longer any blocks available, counterweight adjustments can always be made by adding steel plates, shapes, or rails.

Figure 21.12 shows the results of a balance check of a rolling lift bridge. In this case, the bridge had been in operation for many years and the owner wanted to replace the timber ties with newer, heavier ties. As shown, the imbalance varied with the position of the span and in the open position the center of gravity was behind the center of rotation. It would be preferable to have all the imbalance on the span side, and to reduce the imbalance. One needs to be careful as an increased imbalance can have a chain reaction and cause an increase in the drive machinery and bridge power requirements.

In general, it is good practice to balance a span so that it is slightly too heavy for a bascule bridge and slightly span heavy for a vertical lift bridge, the idea being that the span will tend to stay closed under its own weight and will not bounce under live load (although once the span locks are engaged the span cannot rise). The amount of imbalance needs to be included in designing the bridge-operating machinery, so that it can tolerate the imbalance in combination with all the other machinery design loads.

21.3.4 Movable Bridge Decks

An important part of the design of movable bridges is to limit the moving dead load which affects the size of the counterweight, the overall size of the main structural members, and, to a lesser extent,

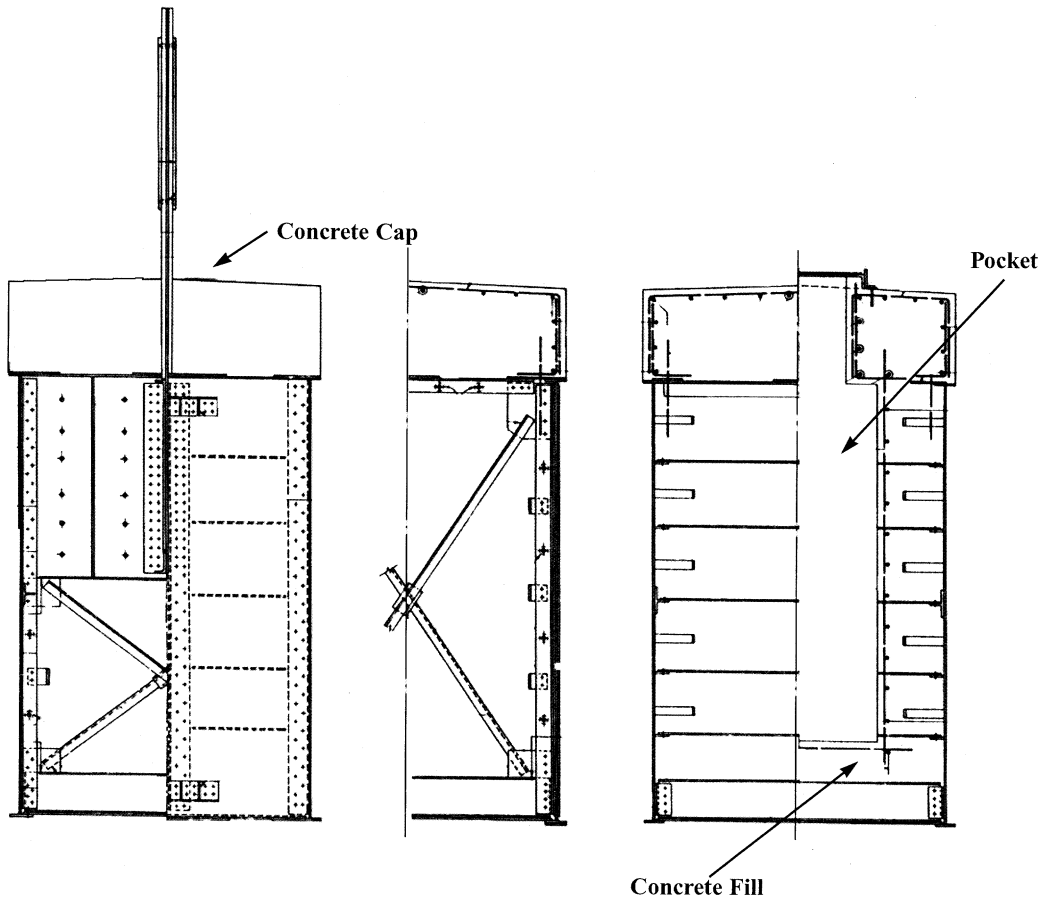

FIGURE 21.11 Typical counterweight configuration for a vertical lift bridge.

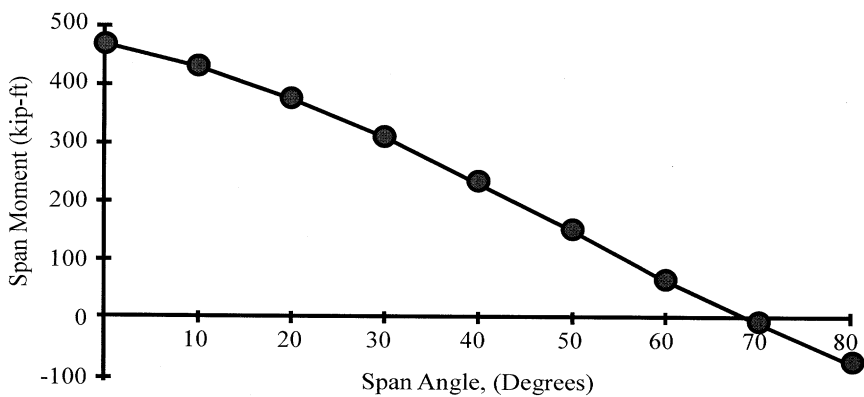

FIGURE 21.12 Results of balance check of a rolling lift bridge.

the machinery depending upon the type of movable bridge. For movable railroad bridges this is typically not a problem, as movable span decks are designed with open decks (timber ties on stringers) and the design live load is such a large part of the overall design load that the type of deck is not an issue. For highway bridges, however, the type of deck needs to be carefully selected to provide a minimum weight while providing an acceptable riding surface. Early movable spans

used timber decks, but they are relatively heavy and have poor traction and wear. Timber was replaced by open steel grid, which at 20 to 25 psf (98 to 122 kg/m²) was a good solution that is both lightweight and long wearing. In addition, the open grid reduced the exposed wind area, particularly for bascule bridges in the open position. However, with higher driving speeds, changes in tires and greater congestion, steel grid deck has become the source of accidents, particularly when wet or icy. Now most new movable bridge decks are designed with some type of solid surface. Depending on the bridge, this can be a steel grid partially filled with concrete or epoxy, an orthotropic deck, lightweight concrete, or the Exodermic system. Aluminum and composite decks are also now being developed and may prove to be a good solution. While orthotropic decks would seem to be a good solution, as the deck can be used as part of the overall structural system, they have not yet seen widespread use in new designs. The reader is referred to Chapters 14 and 24 for information on bridge decks.

21.3.5 Vessel Collision

Movable bridges are typically designed with the minimum allowable channel. As a result, vessel collision is an important aspect as there may be a somewhat higher probability of ship collision than with a fixed bridge with a larger span. There are two factors that are unique to movable bridges with regard to fender (and vessel collision) design. The first is that if a large vessel is transiting the crossing, the bridge will be in the open position and traffic will be halted away from the main span. As a result, the potential consequences of a collision are less than they would be with a fixed bridge ship collision. On the other hand, a movable bridge is potentially more vulnerable to misalignment or extensive damage than a fixed bridge. This is because not only are the spans supported by machinery, but movable spans by their very nature lack the continuity of a fixed bridge. There is no code to govern these issues, but they need to be considered in the design of a movable bridge. The configuration of the piers is an important aspect of this consideration. The reader is referred to Chapter 60, Vessel Collision Analysis and Design.

21.3.6 Seismic Design

The seismic design of movable bridges is also a special issue because they represent a large mass, which may include a large counterweight, supported on machinery that is not intended to behave in a ductile manner. In addition, the movable span is not joined to the other portions of the structure thus allowing it to respond in a somewhat independent fashion. The AREA Manual [3], Chapter 9 covers the seismic design of railroad bridges. However, these guidelines specifically exclude movable bridges. For movable highway bridges, the AASHTO *Standard Specification for Movable Highway Bridges* [4] requires that movable bridges that are normally in the closed position shall be designed for one half the seismic force in the open position. The interpretation of this provision is left up to the designer. The reader is referred to Part IV for an additional discussion of seismic investigation.

21.4 Bridge Machinery

Currently, bridge machinery is designed with either a mechanical or hydraulic drive for the main drive and usually a mechanical drive for the auxiliary machinery items such as span locks and wedges. This is true for all types of movable bridges and the choice of mechanical vs. hydraulic drive is usually based on a combination of owner preference and cost — although other factors may also be considered. Mechanical drives are typically simple configurations based on machinery design principles that were developed long before movable bridges, although now drives use modern enclosed speed reducers and bearings. Overall, these systems have performed very well with sometimes limited maintenance. More recently, hydraulic machinery has been introduced in movable bridge design and it has proved to be an effective solution, as the hydraulics can be closely matched

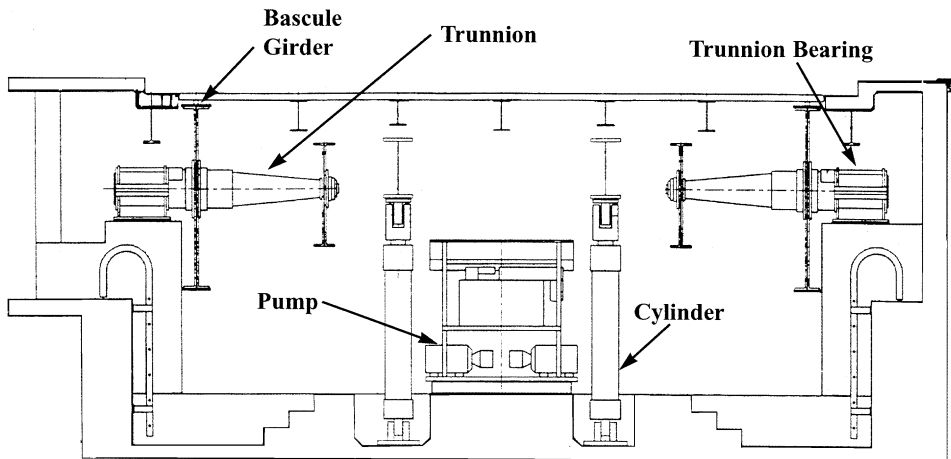

FIGURE 21.13 Section through a bascule pier showing girder trunnions and hydraulic cylinders.

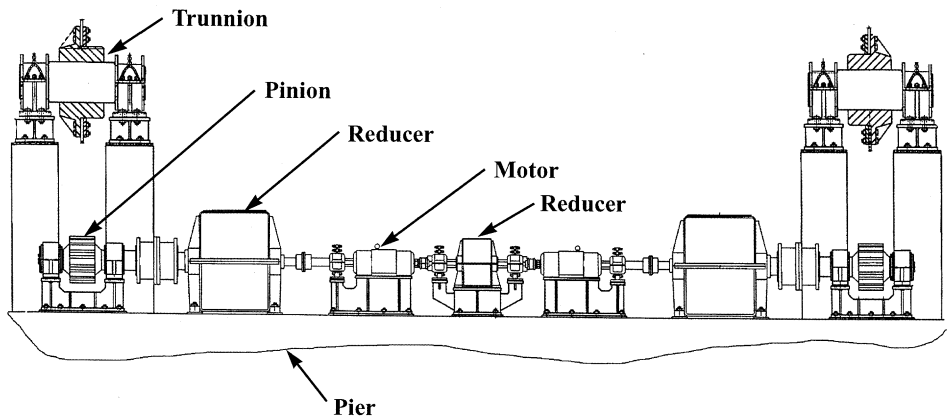

FIGURE 21.14 Section through a bascule pier that utilizes a mechanical drive.

to the power demands, which require good speed control over a wide range of power requirements. Also, there are many firms that furnish hydraulic machinery. However, the systems also require a more-specialized knowledge and maintenance practice than was traditionally the case with mechanical drives.

Figure 21.13 shows a section through a bascule pier illustrating the layout of the bascule girder trunnions (about which the bascule girders rotate) as well as the hydraulic cylinders used to operate the span. Typical design practice is to provide multiple cylinders so that one or more can be removed for maintenance while the span remains in operation. The cylinder end mounts incorporate spherical bearings to accommodate any misalignments. Note that the hydraulic power pack, consisting of a reservoir, motors, pumps, and control valves, is located between the cylinders. Typically redundant motors and pumps are used and the valves can be hand operated if the control system fails. As movable bridges are located in waterways, the use of biodegradable hydraulic fluids is favored in case of a leak or spill.

Figure 21.14 shows a similar section through a bascule pier that utilizes a mechanical drive. What is not shown is the rack attached to the bascule girder. Note the different arrangement here of the trunnions, with bearings on either side of the girders. The central reducer contains a differential, similar to the differential in a vehicle, that serves to equalize the torque in these two drive shafts. As shown, there are two drive motors and typically the span will be designed to operate with only

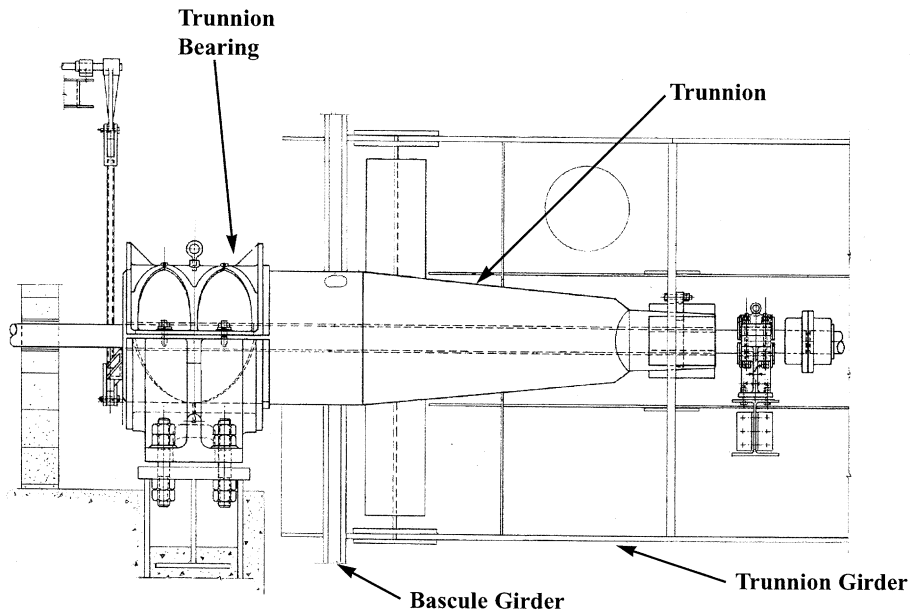

FIGURE 21.15 Trunnion and trunnion bearing.

one motor in operation either as a normal or emergency condition. Also note the extensive use of welded steel frames to support the machinery. It is important that they be stress relieved after assembly but prior to machining and that they be carefully detailed to avoid reentrant corners that could, in time, be a source of cracks.

Figure 21.15 is an illustration of a trunnion and trunnion bearing. The trunnions are fabricated from forged steel and, in this case, are supported on one end by a trunnion bearing and on the other by a trunnion girder that spans between the bascule girders. In this figure a sleeve-type trunnion bearing is shown. The use of sleeve bearings in this type of arrangement is not favored by some designers because of concern with uneven stress on the lining due to deformation of the trunnions and trunnion girder, particularly as the span rotates. Alternative solutions include high-capacity spherical roller bearings and large spherical plain bearings. The crank arrangement shown on the left side of the figure is associated with a position indicator.

Figure 21.16 shows a typical arrangement of the treads for a rolling lift bascule.

Figure 21.17 is a typical drive mechanism for a vertical lift bridge, with a tower drive. The drive is somewhat similar to that used for a bascule bridge except that the pinion drives the rack attached to a sheave rather than a rack attached to a bascule girder. Although a mechanical drive is shown, a similar arrangement could be accomplished with hydraulic motors.

Figure 21.18 is a typical welded sheave used for a vertical lift bridge. As shown, there are 16 rope grooves so this would be associated with a large vertical lift bridge. Typically there are four sheaves for a vertical lift bridge, one at each corner of the lift span. The trunnion bearing is not shown but would be similar to that shown in a bascule bridge trunnion. While sleeve bearings are commonly used, spherical type bearings are also considered to allow for trunnion flexure.

Figure 21.19 shows a span lock typically used between the leaves of a two-leaf bascule bridge. In this case a manufactured unit is illustrated. It incorporates a motor, brake, reducer, and lock bars. Alternative arrangements with a standard reducer are also used, although for this type of an installation the compactness and limited weight favor a one piece unit. It is important that provisions be included for replacement of the wearing surfaces in the lock bar sockets and realignment as they receive considerable wear.

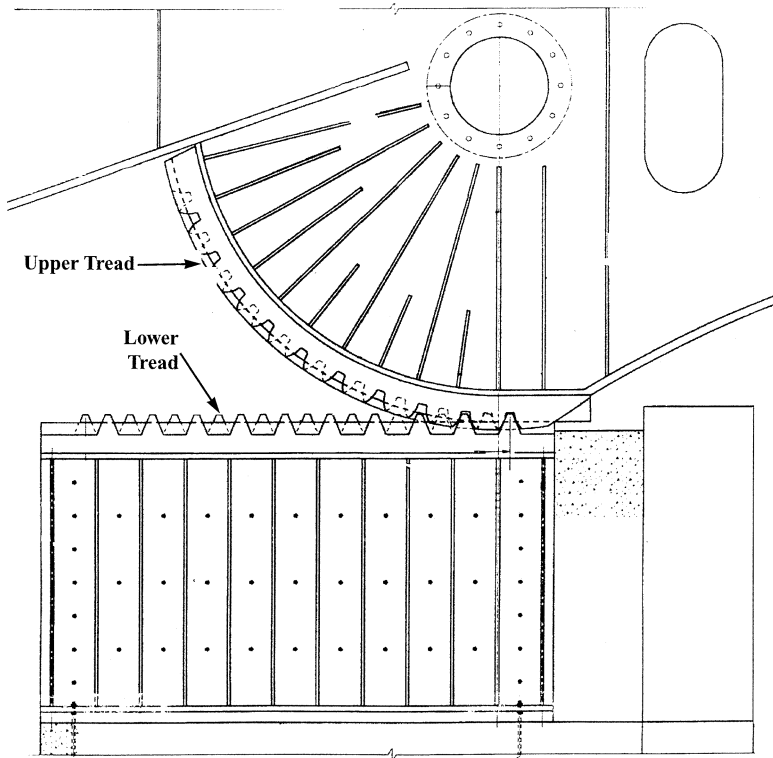

FIGURE 21.16 Treads for a rolling lift bascule.

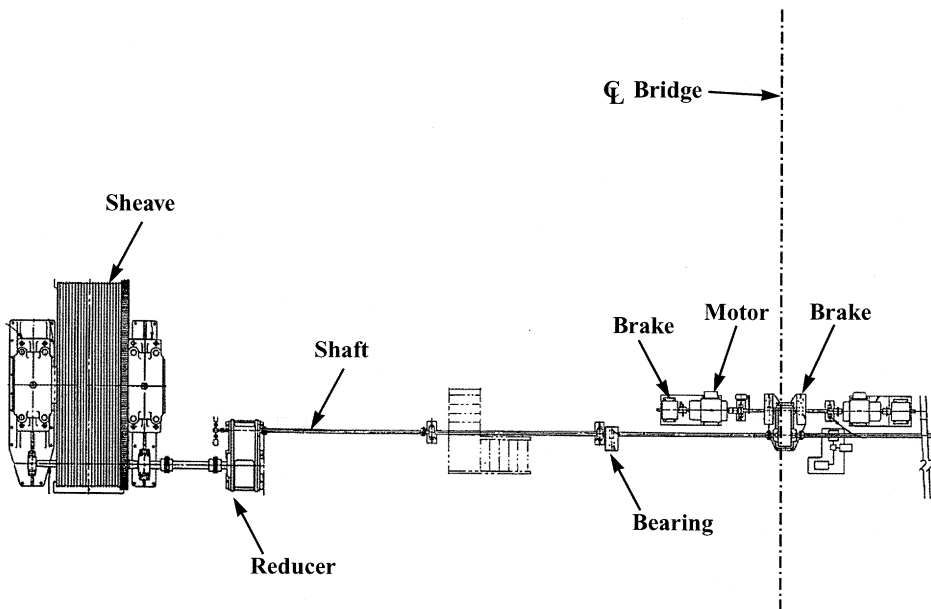

FIGURE 21.17 Drive mechanism for vertical lift bridge.

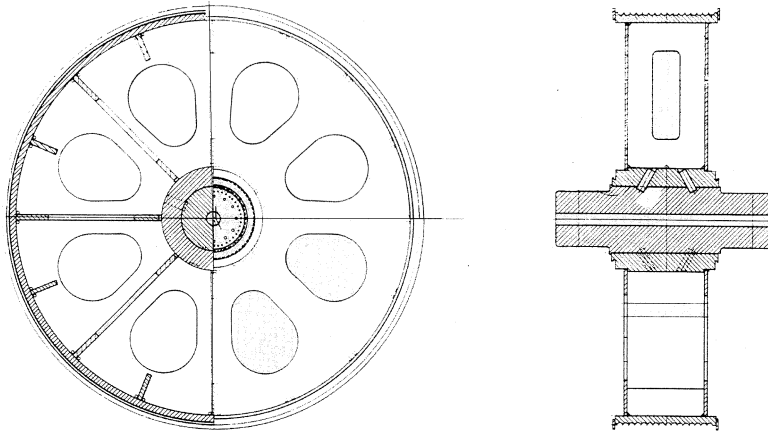

FIGURE 21.18 Welded sheave for a vertical lift bridge.

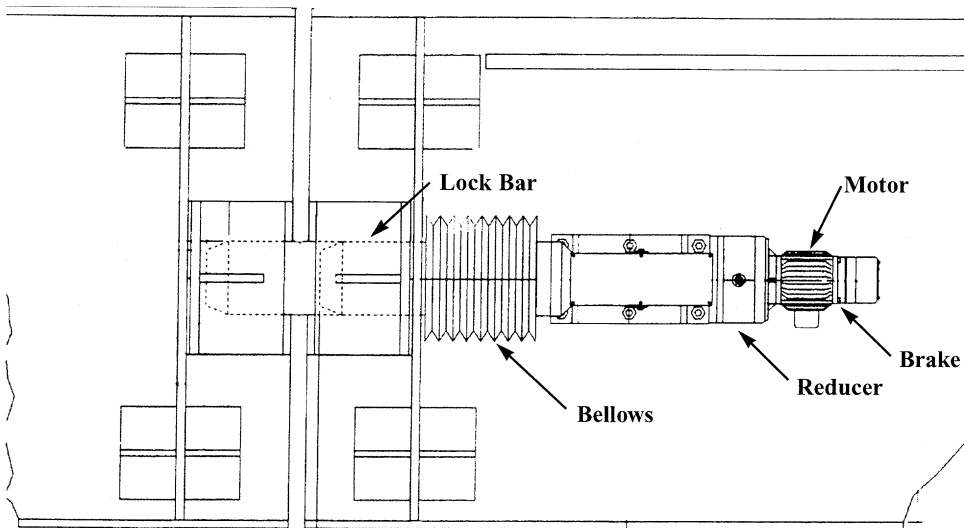
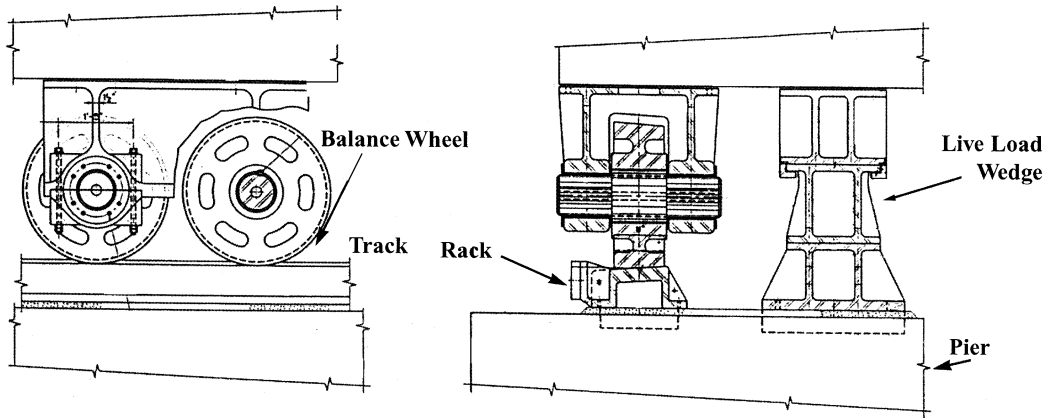

FIGURE 21.19 Span lock between leaves of a two-leaf bascule bridge.

Figures 21.20 and 21.21 show a pivot bearing, balance wheel, and live-load wedge arrangement typically used for a center pivot swing span. For highway bridges AASHTO states, “Swing bridges shall preferably be the center bearing type.” No such preference is indicated by AREA. The center pivot, which contains a bronze bearing disk, carries the dead load of the swing span. The balance wheels are only intended to accommodate unbalanced wind loads when the span moves so that they are adjusted to be just touching the roller track. The wedges are designed to carry the bridge live load and are retracted prior to swinging the span.

Figure 21.22 shows a rim-bearing-type swing span arrangement. Note that it is much more complicated than the center pivot arrangement shown above. The rollers must be designed to carry dead, live, and impact loads and, unlike the intermittent rollers used for a center pivot bridge, need to be placed in a continuous fashion all around the rim. The purpose of the center pivot is to keep the rollers centered, and for some bridges to carry a portion of the dead and live load. Figure 21.23 shows an end lift device used for a swing span.



Typical Balance Wheels

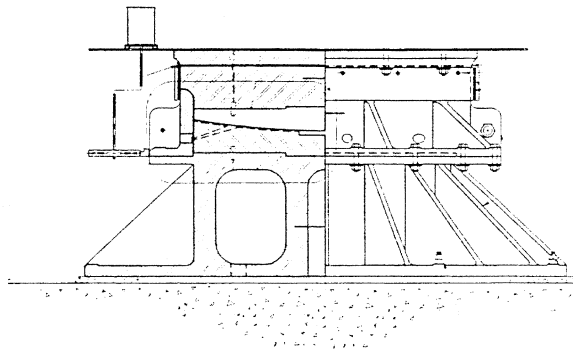

Pivot Bearing

FIGURE 21.20 Balance wheels and pivot bearing for a center pivot swing span.

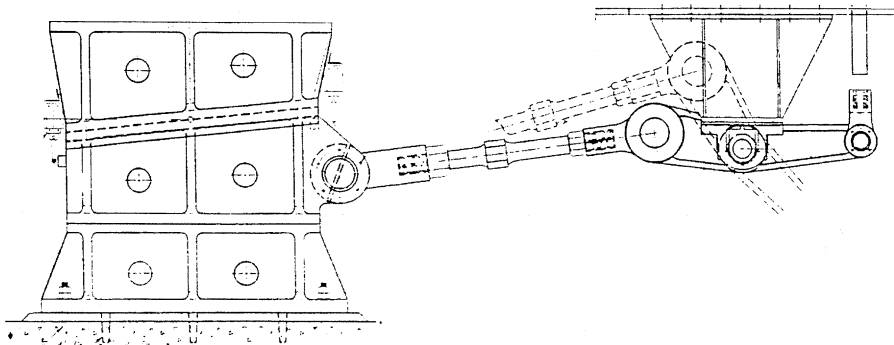

FIGURE 21.21 Live-load wedge arrangement for center pivot swing span.

Figure 21.24 shows a mechanical drive arrangement for a swing span, and similar arrangements can be adapted to both pivot and rim-bearing bridges. A common problem with this arrangement is the pinion attachment to the structural supports as very high forces can be induced in braking the swing span when stopping and these supports tend to be a maintenance problem. Figure 21.25

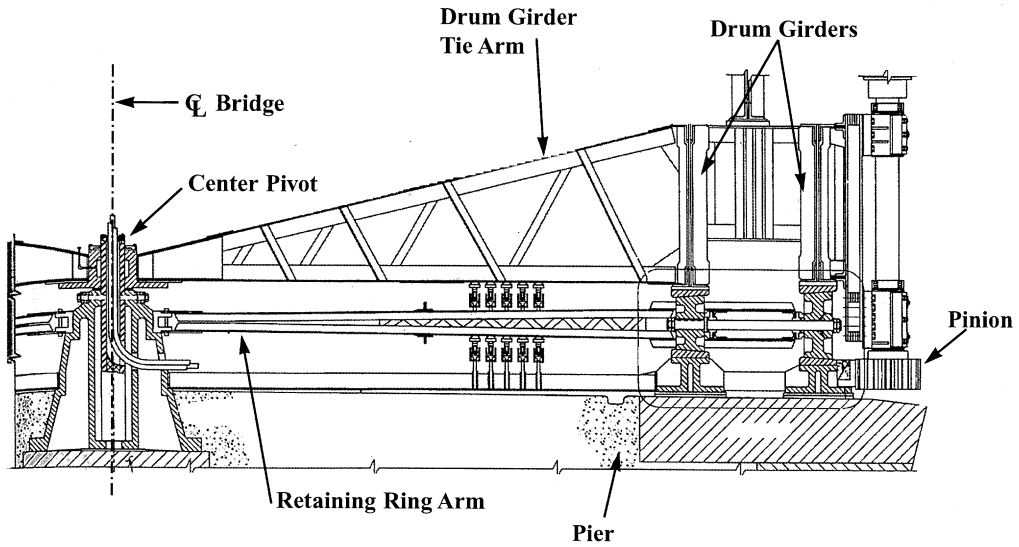

FIGURE 21.22 Rim-bearing swing span arrangement.

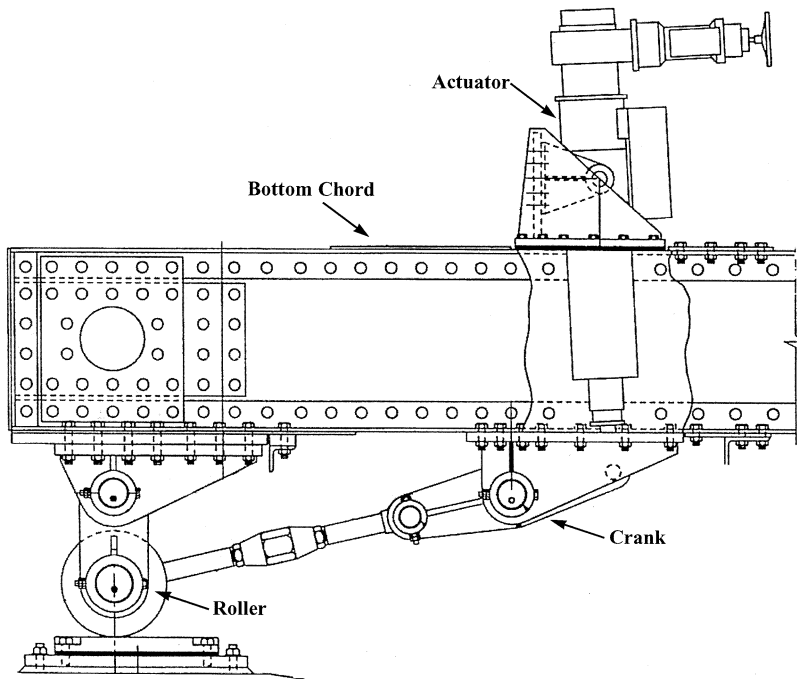

FIGURE 21.23 End lift device for a swing span.

illustrates one of four hydraulic drives from the Coleman Bridge. This drive has an eccentric ring mount so that the pinion/rack backlash can be adjusted.

Figure 21.26 shows a hydraulic drive for a swing span using hydraulic cylinders.

Figure 21.27 shows a typical air buffer. These are provided at the ends of the movable span. With modern control systems, particularly with hydraulics, buffers may not be required to assist in seating. For many years these were custom-fabricated but, if required, one can now utilize off-the-shelf commercial air or hydraulic buffers, as is shown here.

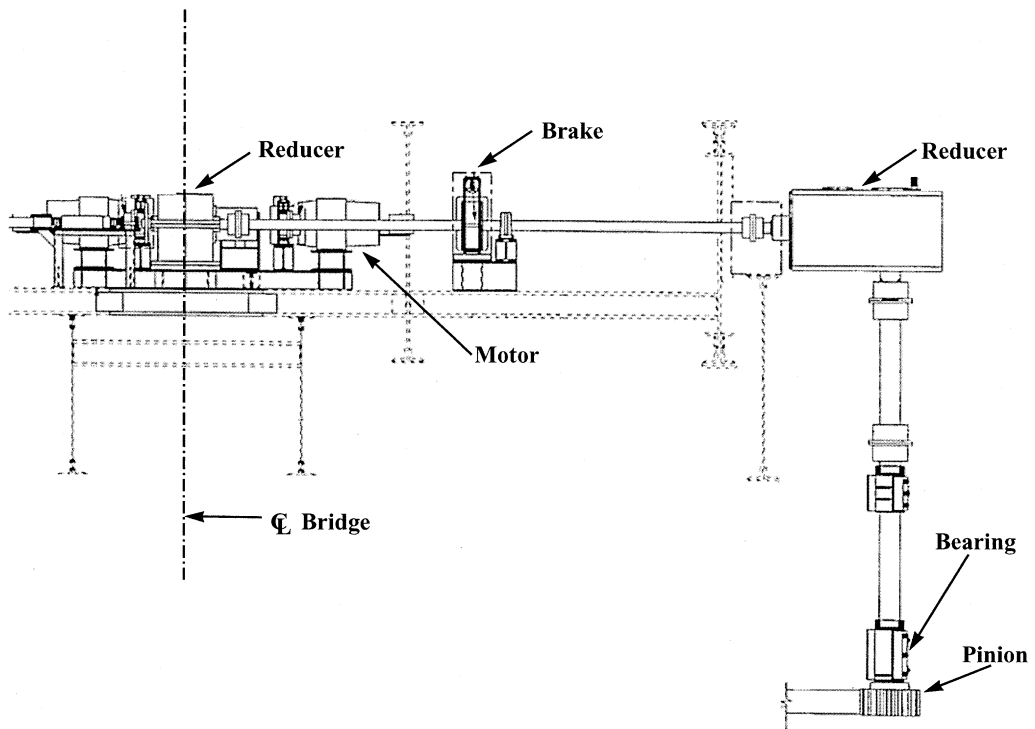

FIGURE 21.24 Mechanical drive arrangement for a swing span.

21.5 Bridge Operation, Power, and Controls

21.5.1 Bridge Operations

Movable bridges are designed to be operated following a set protocol, and this protocol is incorporated into the control system as a series of permissive interlocks. The normal sequence of operation is as follows:

Vessel signals for an opening, usually through a marine radio but it can be through a horn. For a highway bridge the operator sounds a horn, activates the traffic signals, halting traffic, lowers the roadway gates, then lowers the barrier gates. For a rail bridge the operator needs to get a permissive signal from the train dispatcher.

After the barrier gates are lowered, a permissive signal allows the operator to withdraw the locks and/or wedges and lifts and, once that is completed, to open the span. The vessel then can proceed through the opening. To close the bridge, the steps are reversed.

The controls are operated from a control desk and [Figure 21.28](#) shows a typical control desk layout. Note that the control desk includes a position indicator to demonstrate the movable span(s) position as well as an array of push buttons to control the operation. A general objective in designing such a desk is to have the position of the buttons mimic the sequence of operations. Typically, the buttons are lit to indicate their status.

21.5.2 Bridge Power

In the early years, when the streets of most cities had electric trolleys, movable bridges were operated on the 500 VDC trolley power. As the trolleys were removed, rectifiers were installed on the bridges to transform the utility company AC voltage to DC voltage. Many of the historical movable bridges

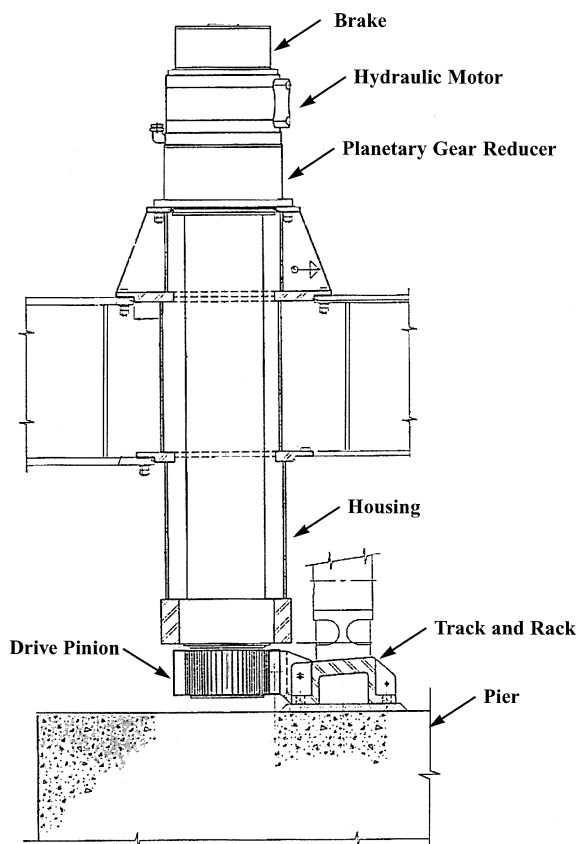
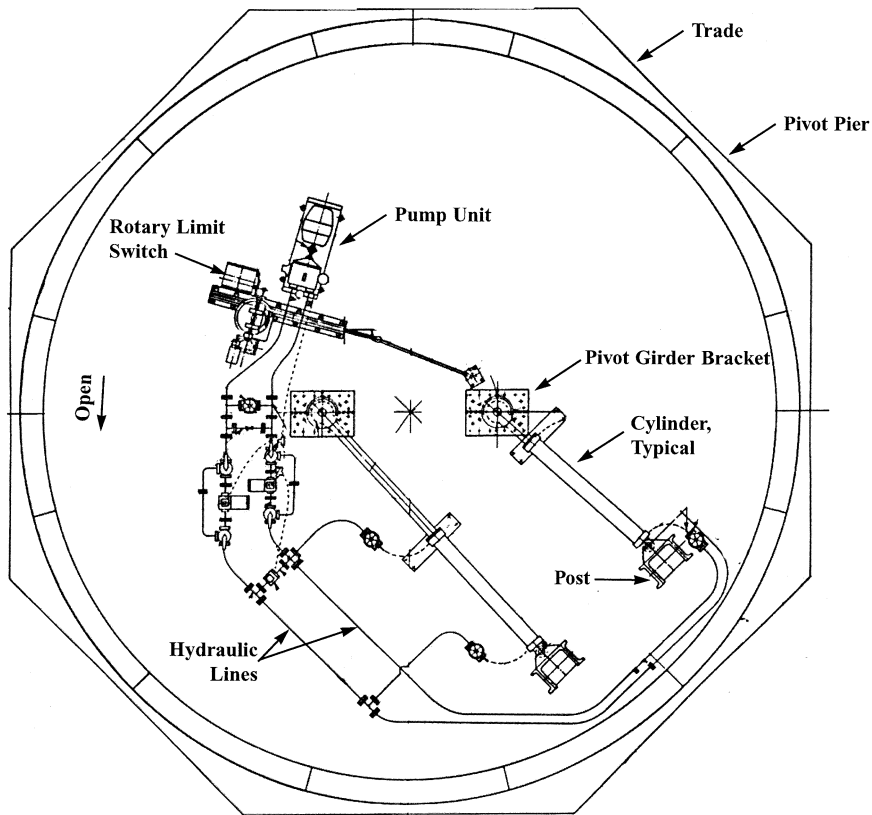

FIGURE 21.25 One of four hydraulic drives from the Coleman Bridge, York River, Virginia.

that are still operating on their original DC motors and drum switch/relay speed controls have these rectifiers. Most of the movable bridges that have been rehabilitated in recent years, but still retain the original DC motors, now have silicon controlled rectifier (SCR) controllers that use AC voltage input and produce a variable DC voltage output directly to the motor.

The most common service voltage for movable bridges is 480 Vac, 3 phase, although in some locations, the service is 240 or 208 Vac, 3 phase. Economics and the utility company policies are the primary determinant factors in what voltage is used. Electrical power, simplified, equals volts times amperes. Thus, for a given horsepower, the motor current at 480 V is one half of that at 240 V. The economics are obvious when one considers the motor frame size, motor controllers, electrical switching equipment, and conductors are all physically smaller for 480 V than for 240 V. However, some utility companies do not normally provide 480 V and they are not willing to maintain a single 480 V service without passing along substantial costs to the bridge owner. If these additional service costs exceed the savings of using 480-V motors and controls, 240-V service becomes more attractive.

The choice of one voltage over the other has no bearing on the cost of power for a movable bridge. Power is power and the rate per kilowatt-hour is the same regardless of voltage. A service cost factor that is sometimes overlooked is the demand charge that utility companies impose on very large intermittent loads. These charges are to offset the utility company cost of reserving power generation and transmission capability to serve the demands of a facility that is normally not online. These charges are based on the peak load, measured at the meter, over a period of, typically, 15 min. The charges are amortized over the year following the last highest reading and added to the billing for the actual amount of electrical power used. In the case of a bridge that has a very high power demand, even if it is opened only once or twice a year, the annual electrical costs are very



Plan View

FIGURE 21.26 Hydraulic drive for a swing span using hydraulic cylinders.

high because the owner has to pay for the demand capacity whether it is used or not. Referring to the earlier discussion on counterweights, it is very important that the design of the bridge is such that it is as energy efficient as possible.

Both AREA [3] and AASHTO [4] require a movable bridge to have an emergency means of operation should primary power be lost. Most bridges are designed with a backup engine driven generator and operate the bridge on the normal electrical motor drives. For safety and reliability, diesel engines are preferred by most bridge owners. Hand operation can be provided as backup for auxiliary devices such as locks, gates, and wedges.

However, there are many different types of backup systems, such as the following:

1. Internal combustion engines or air motors on emergency machinery that can be engaged when needed;
2. Smaller emergency electrical motors on emergency machinery to reduce the size of the emergency generator;
3. A receptacle for a portable emergency generator to reduce the capital investment for emergency power for several bridges, as well as other municipality-owned facilities.

21.5.3 Bridge Control

The predominant control system in use in newly constructed or rehabilitated movable bridges is the programmable logic controller (PLC). This is a computer-based system that has been adapted

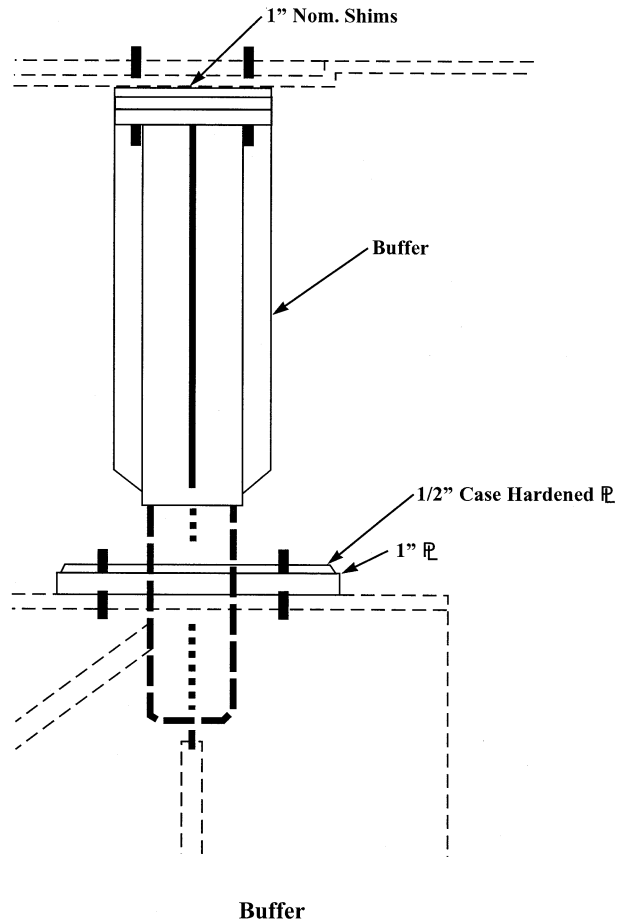

FIGURE 21.27 Typical air buffer.

from other industrial-type applications. The PLC offers the ability to automate the operation of a bridge completely. However, most agencies have used the PLC as a replacement for a relay-based system to reduce the cost of initial construction and to reduce the space required for the control system. Other common applications for the PLC include generation of alarm messages to help reduce time in troubleshooting and maintenance of the systems.

As an example of their widespread use, the New Jersey Department of Transportation has PLCs on all of its bridges and has a proactive training program for its operations and technical staff. However, not all states are using PLCs, as the Florida and Washington State Departments of Transportation are now returning to the relay-based systems because they do not have the technical staff to maintain the PLC.

A more recent development is the use of PLCs for remote operation. For example, the city of Milwaukee, Wisconsin has several bridges that are controlled remotely by means of computer modem links and closed-circuit TV. This reduces the staff to one tender per three bridges. The potential liability of this type of system needs to be carefully evaluated as the bridge operator may not be able to observe adequately all parts of the bridge when operating the span.

Environmental regulations have made the installation permits for submarine cables difficult to obtain. PLC and radio modems have been used in several states to replace the control wiring that would otherwise be in a submarine cable.

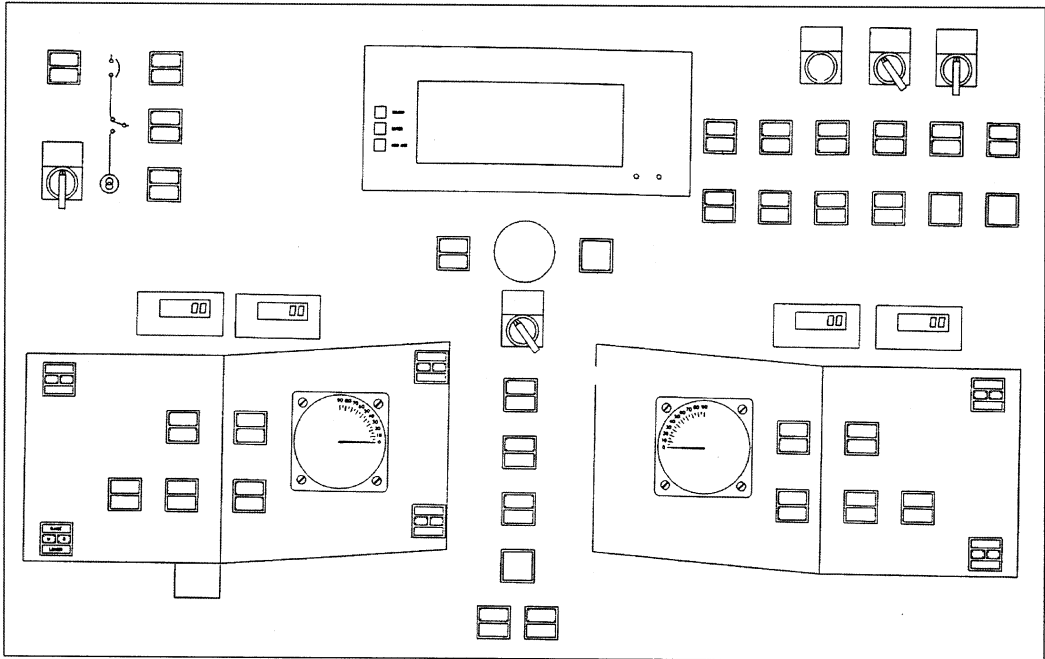

FIGURE 21.28 Layout of a typical control desk.

The selection of a drive system is performance oriented. Reliability and cost are key issues. The most common drives for movable bridges over that past 80 years have been DC and wound rotor AC motors with relays and drum switches. These two technologies remain the most common today although there have been many advances in DC and AC motor controls and the old systems are being rapidly replaced with solid-state drives.

The modern DC drives on movable bridges are digitally controlled, fully regenerative, four-quadrant, SCR motor controllers. In more general terms, this is a solid-state drive that provides infinitely variable speed and torque control in both forward and reverse directions. They have microprocessor programming that provides precise adjustment of operating parameters, and once a system is set up, it rarely needs to be adjusted. Programmable parameters include acceleration, deceleration, preset speeds, response rate, current/torque limit, braking torque, and sequence logic. This type of drive has been proved to provide excellent speed and torque control for bridge-operating conditions.

The wound rotor motor drive technology has also moved into digital control. The new SCR variable voltage controllers are in essence crane control systems. While they are not quite as sophisticated as the DC drives, they have similar speed and torque control capabilities. Most of the movable bridge applications have been retrofitted using the existing motors.

Adjustable frequency controllers (AFC) control speed by varying the frequency of the AC voltage and current to a squirrel cage induction motor. This type of drive has been used on movable bridges with some success but it is not well suited for this type of application. There are two primary reasons. First, this type of drive was designed for the control of pumps and fans, not high-inertia loads. Second, at low speeds, it does not provide sufficient braking torque to maintain control of an overhauling load. This is a significant concern when seating a span with an ice and snow load.

The first flux vector-controlled AFC has been in use on a movable bridge for approximately 6 years now. It is a somewhat sophisticated drive system that controls magnetic flux to create slip artificially and thus control torque at any speed including full-rated motor torque at zero speed.

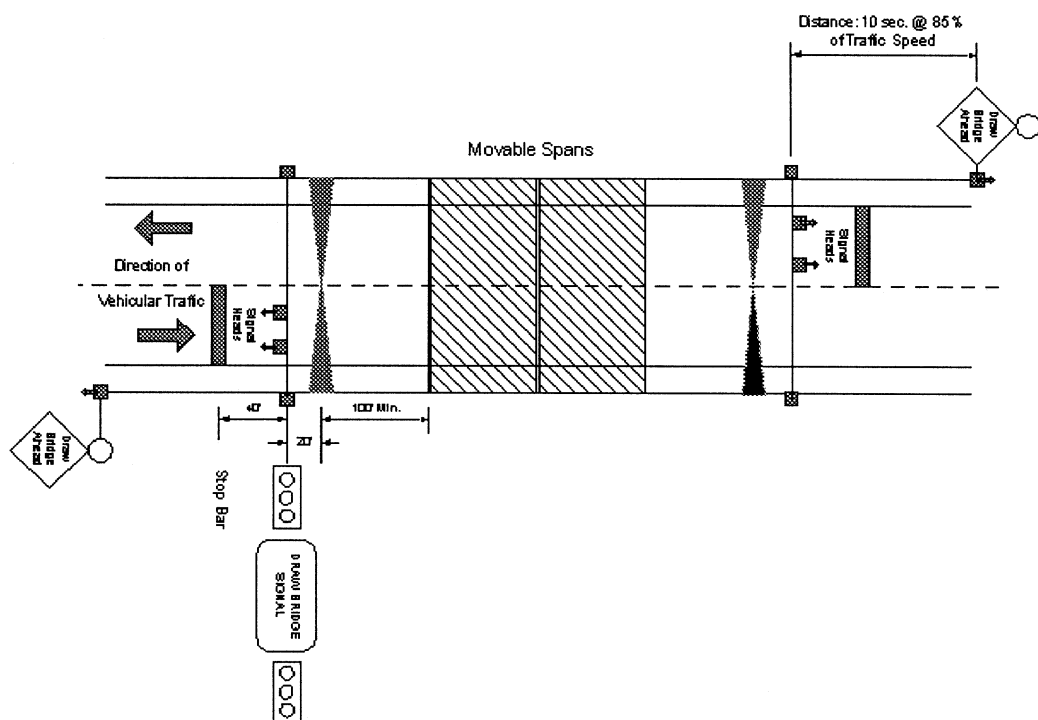

FIGURE 21.29 Typical layout of movable bridge signals and gates.

The drive controller uses input from a digital shaft encoder to locate the motor rotor position and then calculates how much voltage and current to provide to each motor lead. The drive is capable of 100% rated torque at zero speed which gives it excellent motion control at low speeds.

21.6 Traffic Control

Rail traffic control for movable railroad bridges involves interlocking the railroad signal system with the bridge-operating controls. For a movable bridge that is on a rail line that has third rail or catenary power, the interlocking must include the traction power system. In principle, the interlocking needs to be designed so that the railroad signals indicate that the track is closed and the power is deenergized prior to operating the span. However, the particulars of how this is accomplished depends upon the railroad in question and will not be addressed here. For a movable highway bridge, highway traffic control is governed by the AASHTO Movable Highway Bridge Specifications [4], as well as the Manual for Uniform Traffic Control Devices (MUTCD) [8]. Each owner may impose additional requirements but the Manual is typically used in the United States. As a minimum this will include a DRAWBRIDGE AHEAD warning sign, traffic signal, warning (or roadway) gates, and usually resistance (or barrier) gates. One possible arrangement is shown in Figure 21.29 for a two-leaf bascule bridge, note that there are no resistance gates. AASHTO [4] requires that a resistance gate (positive barrier) be placed prior to a movable span opening except where the span itself, such as a bascule leaf, blocks the opening.

For marine traffic, navigation lighting must follow the requirements of the Bridge Permit as approved by the U.S. Coast Guard. The permit typically follows the Coast Guard requirements as found in the U.S. Code of Federal Regulations 33, Part 118, Bridge Lighting and Other Systems [9]. These regulations identify specific types and arrangements for navigation lights depending upon the type of movable bridge.

References

1. American Railway Engineering Association, *Manual of Railway Engineering*, 1922.
2. American Association of State Highway Officials, *Standard Specifications for Movable Highway Bridges*, 1938.
3. *AREA Manual for Railway Engineering*, Chapter 15, Steel Structures, Part 6, Movable Bridges, 1997.
4. AASHTO, *Standard Specifications for Movable Highway Bridges*, 1988.
5. AASHTO, *Standard Specifications for Highway Bridges*, 16th Ed., 1996.
6. Ecalle, H., G. Brown, and P. Kocsis, Chicago type bascule balancing: a new technique, Technical Notes, *ASCE J. Struct. Div.*, 103(ST11), 2269–2272, November 1977.
7. Lu, Malvern, Jenkins, Allred and Biwas, Balancing of trunnion type bascule bridges, *ASCE J. Struct. Div.*, V. 108, (ST10), October 1982.
8. Federal Highway Administration, *Manual on Uniform Traffic Control Devices*.
9. U.S. Code of Federal Regulations 33, Part 118, Bridge Lighting and Other Systems.