

Harazaki, I., Suzuki, S., Okukawa, A. "Suspension Bridges."  
*Bridge Engineering Handbook.*  
Ed. Wai-Fah Chen and Lian Duan  
Boca Raton: CRC Press, 2000

# 18

## Suspension Bridges

---

Atsushi Okukawa

Shuichi Suzuki

Ikuro Harasaki

*Honshu-Shikoku Bridge Authority  
Japan*

### 18.1 Introduction

Origins • Evolution of Modern Suspension Bridges • Dimensions of Suspension Bridges in the World

### 18.2 Structural System

Structural Components • Types of Suspension Bridges • Main Towers • Cables • Suspended Structures • Anchorages

### 18.3 Design

General • Analytical Methods • Design Criteria • Wind-Resistant Design • Seismic Design • Main Towers • Cables • Suspended Structures

### 18.4 Construction

Main Towers • Cables • Suspended Structures

### 18.5 Field Measurement and Coatings

Loading Test • Field Observations • Coating Specification • Main Cable Corrosion Protection

## 18.1 Introduction

---

### 18.1.1 Origins

The origins of the suspension bridge go back a long way in history. Primitive suspension bridges, or simple crossing devices, were the forebears to today's modern suspension bridge structures. Suspension bridges were constructed with iron chain cables over 2000 years ago in China and a similar record has been left in India. The iron suspension bridge, assumed to have originated in the Orient, appeared in Europe in the 16th century and was developed in the 18th century. Although wrought iron chain was used as the main cables in the middle of the 18th century, a rapid expansion of the center span length took place in the latter half of the 19th century triggered by the invention of steel. Today, the suspension bridge is most suitable type for very long-span bridge and actually represents 20 or more of all the longest span bridges in the world.

### 18.1.2 Evolution of Modern Suspension Bridges

#### Beginning of the Modern Suspension Bridge

The modern suspension bridge originated in the 18th century when the development of the bridge structure and the production of iron started on a full-scale basis. Jacobs Creek Bridge was constructed by Finley in the United States in 1801, which had a center span of 21.3 m. The bridge's distinguishing feature was the adoption of a truss stiffening girder which gave rigidity to the bridge

to distribute the load through the hanger ropes and thus prevent excessive deformation of the cable. The construction of the Clifton Bridge with a center span of 214 m, the oldest suspension bridge now in service for cars, began in 1831 and was completed in 1864 in the United Kingdom using wrought iron chains.

### **Progress of the Center Span Length in the First Half of the 20th Century in the United States**

The aerial spinning method (AS method) used for constructing parallel wire cables was invented by Roebling during the construction of the Niagara Falls Bridge, which was completed in 1855 with a center span of 246 m. The technology was established in the Brooklyn Bridge, completed in 1883 with a center span of 486 m, where steel wires were first used. The Brooklyn Bridge, which is hailed as the first modern suspension bridge, was constructed across New York's East River through the self-sacrificing efforts of the Roebling family — father, son, and the daughter-in-law — over a period of 14 years.

In 1903, the Manhattan Bridge, with a center span of 448 m, and in 1909 the Williamsburg Bridge, with a center span of 488 m, were constructed on the upper reaches of the river. The first center span longer than 1000 m was the George Washington Bridge across the Hudson River in New York. It was completed in 1931 with a center span of 1067 m. In 1936, the San Francisco–Oakland Bay Bridge, which was twin suspension bridge with a center span of 704 m, and in 1937, the Golden Gate Bridge with a center span of 1280 m were constructed in the San Francisco Bay area.

In 1940, the Tacoma Narrows Bridge, with a center span of 853 m, the third longest in the world at that time, exhibited bending mode oscillations of up to 8.5 m with subsequent torsional mode vibrations. It finally collapsed under a 19 m/s wind just 4 months after its completion. After the accident, wind-resistant design became crucial for suspension bridges. The Tacoma Narrows Bridge, which was originally stiffened with I-girder, was reconstructed in 1950 with the same span length while using a truss-type stiffening girder.

The Mackinac Straits Bridge with a center span of 1158 m was constructed as a large suspension bridge comparable to the Golden Gate Bridge in 1956 and the Verrazano Narrows Bridge with a center span of 1298 m, which updated the world record after an interval of 17 years, was constructed in 1964.

### **New Trends in Structures in Europe from the End of World War II to the 1960s**

Remarkable suspension bridges were being constructed in Europe even though their center span lengths were not outstandingly long.

In the United Kingdom, though the Forth Road Bridge, with a center span of 1006 m, was constructed using a truss stiffening girder, the Severn Bridge, with a center span of 988 m, was simultaneously constructed with a box girder and diagonal hanger ropes in 1966. This unique design revolutionized suspension bridge technology. The Humber Bridge, with a center span of 1410 m, which was the longest in the world before 1997, was constructed using technology similar as the Severn Bridge. In Portugal, the 25 de Abril Bridge was designed to carry railway traffic and future vehicular traffic and was completed in 1966 with a center span of 1013 m.

In 1998, the Great Belt East Bridge with the second longest center span of 1624 m was completed in Denmark using a box girder.

### **Developments in Asia since the 1970s**

In Japan, research for the construction of the Honshu–Shikoku Bridges was begun by the Japan Society of Civil Engineers in 1961. The technology developed for long-span suspension bridges as part of the Honshu–Shikoku Bridge Project contributed first to the construction of the Kanmon Bridge, completed in 1973 with a center span of 712 m, then the Namhae Bridge, completed in 1973 in the Republic of Korea with a center span of 400 m, and finally the Hirado Bridge, completed in 1977 with a center span of 465 m.

The Innoshima Bridge, with a center span of 770 m, was constructed in 1983 as the first suspension bridge of the Honshu–Shikoku Bridge Project, followed by the Ohnaruto Bridge, which was designed to carry future railway traffic in addition to vehicular loads and was completed in 1985 with a center span of 876 m. The center route of the Honshu–Shikoku Bridge Project, opened to traffic in 1988, incorporates superior technology enabling the bridges to carry high-speed trains. This route includes long-span suspension bridges such as the Minami Bisan–Seto Bridge, with a center span of 1100 m, the Kita Bisan–Seto Bridge, with a center span of 990 m, and the Shimotsui–Seto Bridge with a center span of 910 m. The Akashi Kaikyo Bridge, completed in 1998 with the world longest center span of 1991 m, represents the accumulation of bridge construction technology to this day.

In Turkey, the Bosphorus Bridge, with a center span of 1074 m, was constructed in 1973 with a bridge type similar to the Severn Bridge, while the Second Bosphorus Bridge with a center span of 1090 m, called the Fatih Sultan Mehmet Bridge now, was completed in 1988 using vertical instead of diagonal hanger ropes.

In China, the Tsing Ma Bridge (Hong Kong), a combined railway and roadway bridge with a center span of 1377 m, was completed in 1997. The construction of long-span suspension bridges of 1000 m is currently considered remarkable, the Xi Ling Yangtze River Bridge with a center span of 900 m and the Jing Yin Yangtze River Bridge with a center span of 1385 m are now under construction [1]. Both suspension bridges have a box stiffening girder and concrete main towers. Besides these bridges, additional long-span suspension bridges are planned.

### 18.1.3 Dimensions of Suspension Bridges in the World

Major dimensions of long-span suspension bridges in the world are shown in [Table 18.1](#).

## 18.2 Structural System

---

### 18.2.1 Structural Components

The basic structural components of a suspension bridge system are shown in [Figure 18.1](#).

1. Stiffening girders/trusses: Longitudinal structures which support and distribute moving vehicle loads, act as chords for the lateral system and secure the aerodynamic stability of the structure.
2. Main cables: A group of parallel-wire bundled cables which support stiffening girders/trusses by hanger ropes and transfer loads to towers.
3. Main towers: Intermediate vertical structures which support main cables and transfer bridge loads to foundations.
4. Anchorages: Massive concrete blocks which anchor main cables and act as end supports of a bridge.

### 18.2.2 Types of Suspension Bridges

Suspension bridges can be classified by number of spans, continuity of stiffening girders, types of suspenders, and types of cable anchoring.

#### Number of Spans

Bridges are classified into single-span, two-span, or three-span suspension bridges with two towers, and multispan suspension bridges which have three or more towers ([Figure 18.2](#)). Three-span suspension bridges are the most commonly used. In multispan suspension bridges, the horizontal displacement of the tower tops might increase due to the load conditions, and countermeasures to control such displacement may become necessary.

**TABLE 18.1** Dimensions of Long-Span Suspension Bridges

No.	Bridge	Country	Year of Completion	Span Lengths (m)	Type	Remarks
1	Akashi Kaikyo	Japan	1998	960+1991+960	3-span, 2-hinged	
2	Great Belt East	Denmark	1998	535+1624+535	Continuous	
3	Humber	U.K.	1981	280+1410+530	3-span, 2-hinged	
4	Jing Yin Yangtze River	China <sup>a</sup>	(1999)	(336.5)+1385+(309.34)	Single-span	
5	Tsing Ma	China <sup>a</sup>	1997	455+1377 (+300)	Continuous	Highway+Railway
6	Verrazano Narrows	U.S.	1964	370.3+1298.5+370.3	3-span, 2-hinged	
7	Golden Gate	U.S.	1937	342.9+1280.2+342.9	3-span, 2-hinged	
8	Höga Kusten	Sweden	1997	310+1210+280	3-span, 2-hinged	
9	Mackinac Straits	U.S.	1957	548.6+1158.2+548.6	3-span, 2-hinged	
10	Minami Bisan–Seto	Japan	1988	274+1100+274	Continuous	Highway+Railway
11	Fatih Sultan Mehmet	Turkey	1988	(210+) 1090 (+210)	Single-span	
12	Bosphorus	Turkey	1973	(231+) 1074 (+255)	Single-span	
13	George Washington	U.S.	1931	185.9+1066.8+198.1	3-span, 2-hinged	
14	3rd Kurushima Kaikyo	Japan	1999	(260+) 1030 (+280)	Single-span	
15	2nd Kurushima Kaikyo	Japan	1999	250+1020 (+245)	2-span, 2-hinged	
16	25 de Abril	Portugal	1966	483.4+1012.9+483.4	Continuous	Highway+Railway
17	Forth Road	U.K.	1964	408.4+1005.8+408.4	3-span, 2-hinged	
18	Kita Bisan–Seto	Japan	1988	274+990+274	Continuous	Highway+Railway
19	Severn	U.K.	1966	304.8+987.6+304.8	3-span, 2-hinged	
20	Shimotsui–Seto	Japan	1988	230+940+230	Single-span with cantilever	Highway+Railway
21	Xi Ling Yangtze River	China <sup>a</sup>	1997	225+900+255	Single-span	
22	Hu Men Zhu Jiang	China <sup>a</sup>	1997	302+888+348.5	Single-span	
23	Ohnaruto	Japan	1985	93+330+876+330	3-span, 2-hinged	Highway+Railway
24	Second Tacoma Narrows	U.S.	1950	335.3+853.4+335.3	3-span, 2-hinged	
25	Askøy	Norway	1992	(173+) 850 (+173)	Single-span	
26	Innoshima	Japan	1983	250+770+250	3-span, 2-hinged	
27	Akinada	Japan	(2000)	255+750+170	3-span, 2-hinged	
28	Hakucho	Japan	1998	330+720+330	3-span, 2-hinged	
29	Angostura	Venezuela	1967	280+712+280	3-span, 2-hinged	
29	Kanmon	Japan	1973	178+712+178	3-span, 2-hinged	
31	San Francisco–Oakland Bay	U.S.	1936	356.9+704.1+353.6 353.6+704.1+353.6	3-span, 2-hinged	

<sup>a</sup> The People's Republic of China.

## Continuity of Stiffening Girders

Stiffening girders are typically classified into two-hinge or continuous types (Figure 18.3). Two-hinge stiffening girders are commonly used for highway bridges. For combined highway–railway bridges, the continuous girder is often adopted to ensure train runnability.

## Types of Suspenders

Suspenders, or hanger ropes, are either vertical or diagonal (Figure 18.4). Generally, suspenders of most suspension bridges are vertical. Diagonal hangers have been used, such as in the Severn Bridge, to increase the damping of the suspended structures. Occasionally, vertical and diagonal hangers are combined for more stiffness.

## Types of Cable Anchoring

These are classified into externally anchored or self-anchored types (Figure 18.5). External anchorage is most common. Self-anchored main cables are fixed to the stiffening girders instead of the anchorage; the axial compression is carried into the girders.

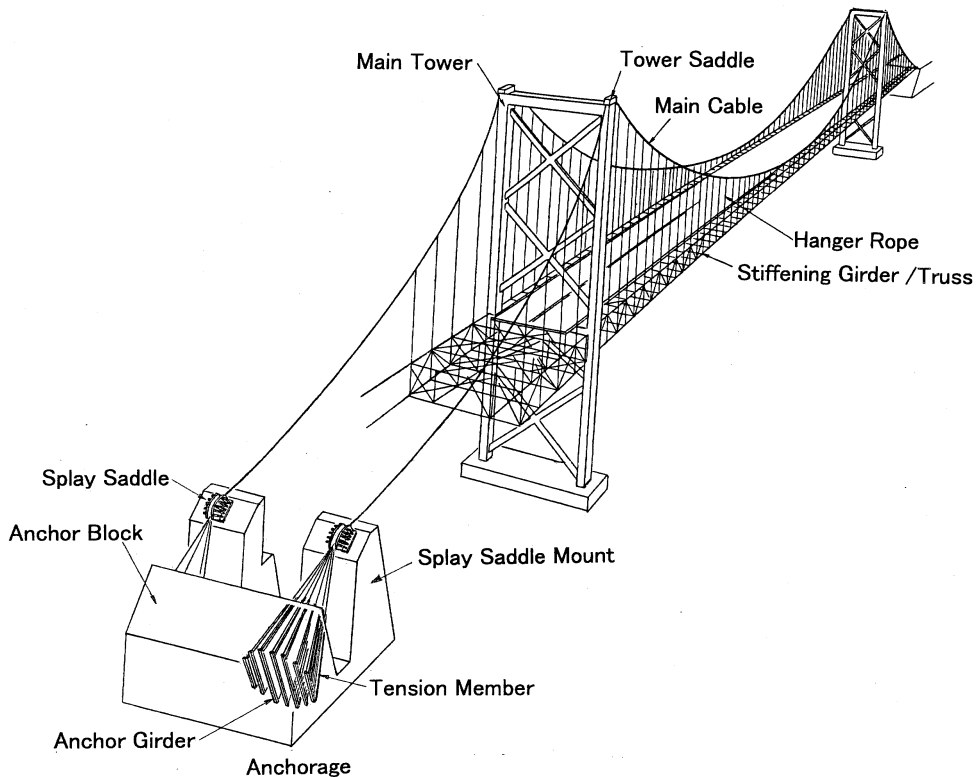

FIGURE 18.1 Suspension bridge components.

### 18.2.3 Main Towers

#### Longitudinal Direction

Towers are classified into rigid, flexible, or locking types (Figure 18.6). Flexible towers are commonly used in long-span suspension bridges, rigid towers for multispan suspension bridges to provide enough stiffness to the bridge, and locking towers occasionally for relatively short-span suspension bridges.

#### Transverse Direction

Towers are classified into portal or diagonally braced types (Table 18.2). Moreover, the tower shafts can either be vertical or inclined. Typically, the center axis of inclined shafts coincides with the centerline of the cable at the top of the tower. Careful examination of the tower configuration is important, in that towers dominate the bridge aesthetics.

### 18.2.4 Cables

In early suspension bridges, chains, eye-bar chains, or other material was used for the main cables. Wire cables were used for the first time in suspension bridges in the first half of the 19th century, and parallel-wire cables were adopted for the first time in the Niagara Falls Bridge in 1854. Cold-drawn and galvanized steel wires were adopted for the first time in the Brooklyn Bridge in 1883. This type has been used in almost all modern long-span suspension bridges. The types of parallel wire strands and stranded wire ropes that typically comprise cables are shown in Table 18.3. Generally, strands are bundled into a circle to form one cable. Hanger ropes might be steel bars, steel

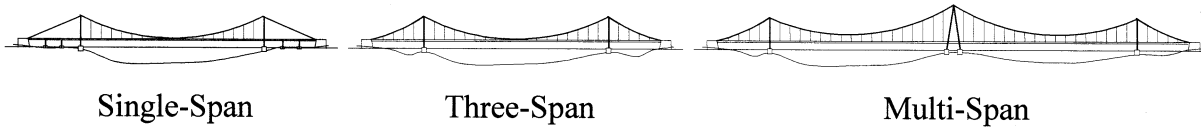

FIGURE 18.2 Types of suspension bridges.

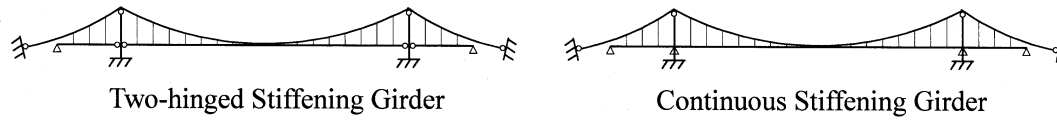

FIGURE 18.3 Types of stiffening girders.

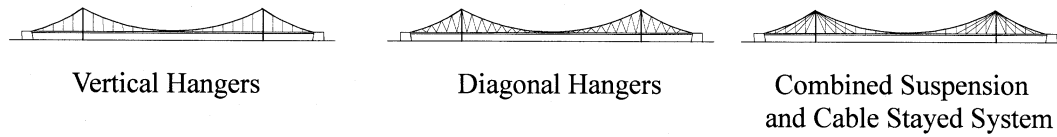

FIGURE 18.4 Types of suspenders.

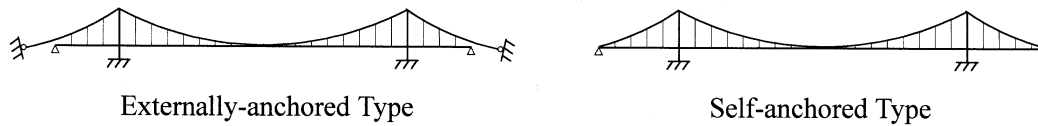

FIGURE 18.5 Types of cable anchoring

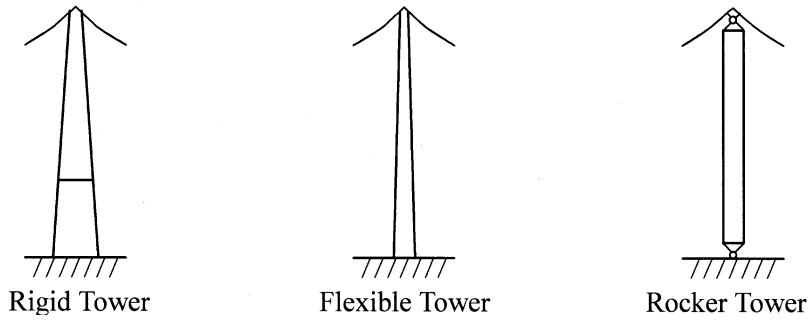

FIGURE 18.6 Main tower structural types.

TABLE 18.2 Types of Main Tower Skeletons

	Truss	Portal	Combined Truss and Portal
Shape			
Bridge	Akashi Kaikyo Forth Road	Great Belt East Humber	Golden Gate Second Tacoma Narrows

TABLE 18.3 Suspension Bridge Cable Types

Name	Shape of section	Structure	Bridge
Parallel Wire Strand		Wires are hexagonally bundled in parallel.	Brooklyn Humber Great Belt East Akashi Kaikyo
Strand Rope		Six strands made of several wires are closed around a core strand.	St.Johns
Spiral Rope		Wires are stranded in several layers mainly in opposite lay directions.	Little Belt Tancarville Wakato
Locked Coil Rope		Deformed wires are used for the outside layers of Spiral Rope.	Kvalsund Emmerich Älvsborg New Köln Rodenkirchen



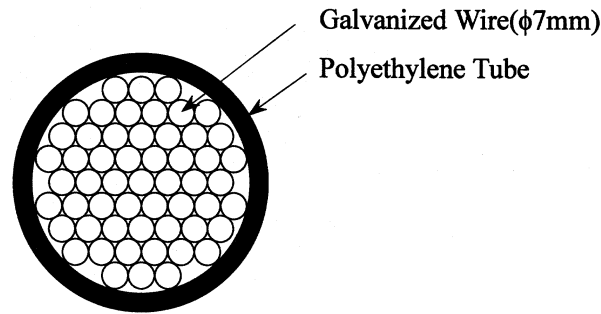

FIGURE 18.7 Parallel wire strands covered with polyethylene tubing.

rods, stranded wire ropes, parallel wire strands, and others. Stranded wire rope is most often used in modern suspension bridges. In the Akashi Kaikyo Bridge and the Kurushima Kaikyo Bridge, parallel wire strands covered with polyethylene tubing were used (Figure 18.7).

### 18.2.5 Suspended Structures

Stiffening girders may be I-girders, trusses, and box girders (Figure 18.8). In some short-span suspension bridges, the girders do not have enough stiffness themselves and are usually stiffened by storm ropes. In long-span suspension bridges, trusses or box girders are typically adopted. I-girders become disadvantageous due to aerodynamic stability. There are both advantages and disadvantages to trusses and box girders, involving trade-offs in aerodynamic stability, ease of construction, maintenance, and so on (details are in Section 18.3.8).

### 18.2.6 Anchorages

In general, anchorage structure includes the foundation, anchor block, bent block, cable anchor frames, and protective housing. Anchorages are classified into gravity or tunnel anchorage system as shown in Figure 18.9. Gravity anchorage relies on the mass of the anchorage itself to resist the tension of the main cables. This type is commonplace in many suspension bridges. Tunnel anchorage takes the tension of the main cables directly into the ground. Adequate geotechnical conditions are required.

## 18.3 Design

---

### 18.3.1 General

Naveir [2] was the first to consider a calculation theory of an unstiffened suspension bridge in 1823. Highly rigid girders were adopted for the suspended structure in the latter half of the 19th century because the unstiffened girders which had been used previously bent and shook under not much load. As a result, Rankine in 1858 [3] attempted to analyze suspension bridges with a highly rigid truss, followed by Melan, who helped complete the elastic theory, in which the stiffening truss was regarded as an elastic body. Ritter in 1877 [4], Lévy in 1886 [5], and Melan in 1888 [6] presented the deflection theory as an improved alternative to the elastic theory. Moisseiff realized that the actual behavior of a suspension bridge could not be explained by the elasticity theory in studies of the Brooklyn Bridge in 1901, and confirmed that the deflection theory was able to evaluate the deflection of that bridge more accurately. Moisseiff designed the Manhattan Bridge using the deflection theory in 1909. This theory became a useful design technique with which other long-span suspension bridges were successfully built [7]. Moreover, together with increasing the span length of the suspension bridge, horizontal loads such as wind load and vertical loads came to govern the design of the stiffening

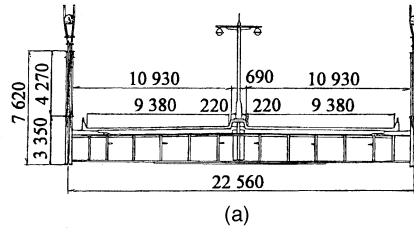

(a)

**I-girder**  
**(Bronx-Whitstone Bridge)**

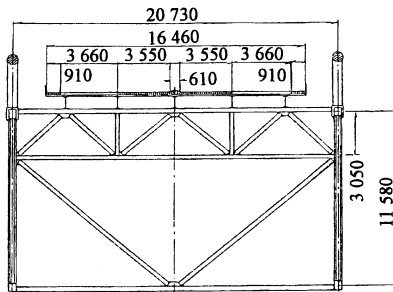

(b)

**Truss Girder**  
**(Mackinac Straits Bridge)**

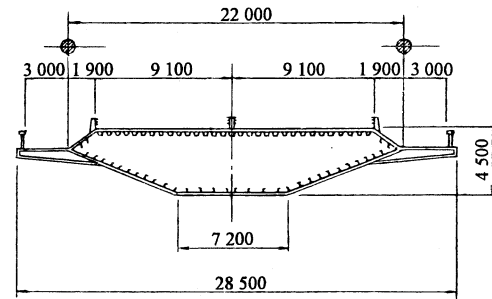

(c)

**Box Girder**  
**(Humber Bridge)**

**FIGURE 18.8** Types of stiffening girders.

girder. Moisseiff was among the first to establish the out-of-plane analysis method for suspension bridges [8].

Currently, thanks to rapid computer developments and the accumulation of matrix analysis studies on nonlinear problems, the finite deformation theory with a discrete frame model is generally used for the analysis of suspension bridges. Brotton [9,10] was the first to analyze the suspension bridge to be a plane structure in the matrix analysis and applied his findings to the analysis at erection stage for the Severn Bridge with good results. Saafan [11] and Tezcan's [12] thesis, which applied the general matrix deformation theory to the vertical in-plane analysis of a suspension bridge was published almost at the same time in 1966. The Newton-Raphson's method or original iteration calculation method may be used in these nonlinear matrix displacement analyses for a suspension bridge.

## 18.3.2 Analytical Methods

### Classical Theory

#### Elastic Theory and Deflection Theory

The elastic theory and the deflection theory are in-plane analyses for the global suspension bridge system. In the theories, the entire suspension bridge is assumed a continuous body and the hanger ropes are closely spaced. Both of these analytical methods assume:

- The cable is completely flexible.
- The stiffening girder is horizontal and straight. The geometric moment of inertia is constant.

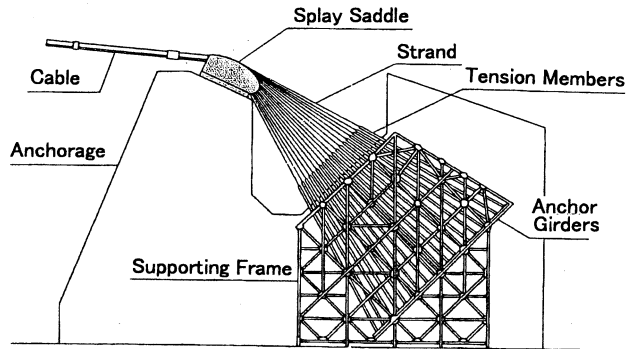

(a)

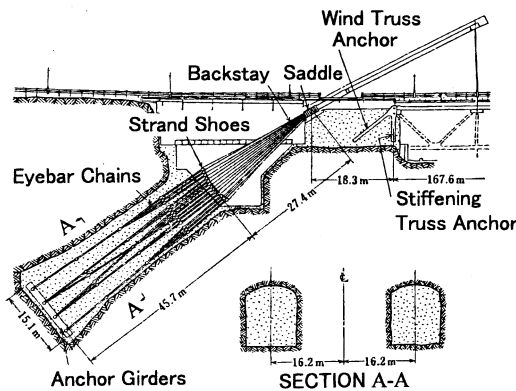

(b)

FIGURE 18.9 Types of anchorages. (a) Gravity, Akashi Kaikyo Bridge; (b) tunnel, George Washington Bridge.

- The dead load of the stiffening girder and the cables is uniform. The coordinates of the cable are parabolic.
- All dead loads are taken into the cables.

The difference between the two theories is whether cable deflection resulting from live load is considered. Figure 18.10 shows forces and deflections due to load in a suspension bridge. The bending moment,  $M(x)$ , of the stiffening girder after loading the live load is shown as follows:

Elastic Theory:

$$M(x) = M_0(x) - H_p y(x) \quad (18.1)$$

Deflection Theory:

$$M(x) = M_0(x) - H_p y(x) - (H_w + H_p) \eta(x) \quad (18.2)$$

where

$M_0(x)$  = bending moment resulting from the live load applied to a simple beam of the same span length as the stiffening girder

$y(x)$  = longitudinal position of the cable

$\eta(x)$  = deflection of the cable and the stiffening girder due to live load

$H_w, H_p$  = cable horizontal tension due to dead load and live load, respectively

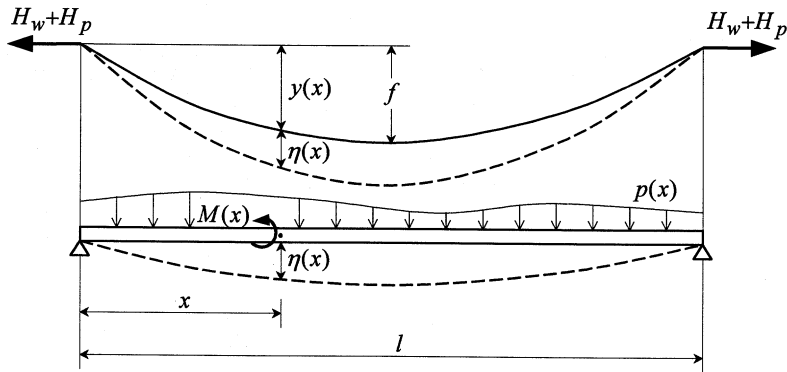

FIGURE 18.10 Deformations and forces of a suspension bridge.

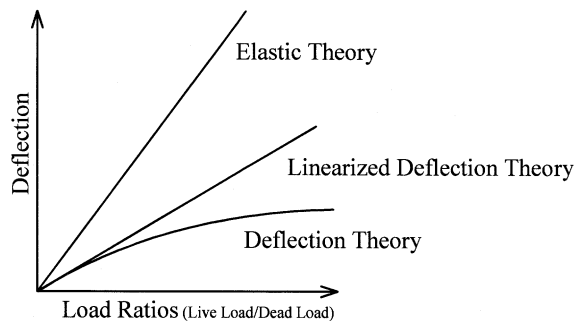

FIGURE 18.11 Deflection–load ratios relations among theories. (Source: Bleich, F. et al., *The Mathematical Theory of Vibrations in Suspension Bridges*, Bureau of Public Roads, Washington, D.C., 1950.)

It is understood that the bending moment of the stiffening girder is reduced because the deflection induced due to live load is considered in the last product of Eq. (18.2). Since the deflection theory is a nonlinear analysis, the principle of superposition using influence lines cannot be applied. However, because the intensity of live loads is smaller than that of dead loads for long-span suspension bridges, sufficient accuracy can be obtained even if it is assumed that  $H_w + H_p$  is constant under the condition of  $H_w \gg H_p$ . On that condition, because the analysis becomes linear, the influence line can be used. Figure 18.11 shows the deflection–load ratio relations among the elastic, deflection, and linearized deflection theories [13]. When the ratio of live load to dead load is small, linearized theory is especially effective for analysis. In the deflection theory, the bending rigidity of towers can be neglected because it has no significance for behavior of the entire bridge.

#### Out-of-Plane Analysis Due to Horizontal Loads

Lateral force caused by wind or earthquake tends to be transmitted from the stiffening girder to the main cables, because the girder has larger lateral deformation than the main cables due to difference of the horizontal loads and their stiffness. Moisseiff [8] first established the out-of-plane analysis method considering this effect.

#### Out-of-Plane Analysis of the Main Tower

Birdsall [14] proposed a theory on behavior of the main tower in the longitudinal direction. Birdsall's theory utilizes an equilibrium equation for the tower due to vertical and horizontal forces from the cable acting on the tower top. The tower shaft is considered a cantilevered beam with variable cross section, as shown in Figure 18.12. The horizontal load ( $F$ ) is obtained on the condition that the vertical load ( $R$ ), acting on the tower top, and the horizontal displacement ( $\Delta$ ) are calculated by using Steinman's generalized deflection theory method [15].

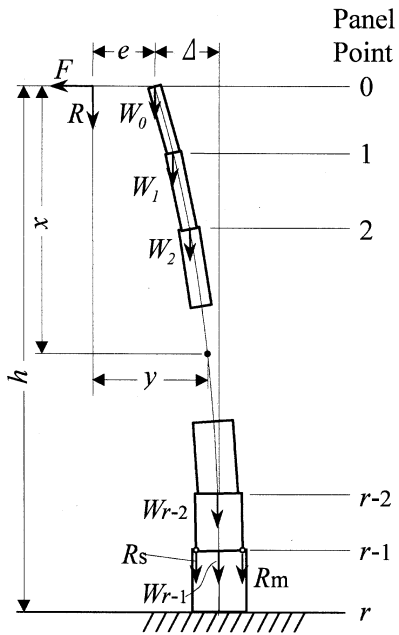

- $F$  :desired horizontal tower-top load
- $R$  :vertical external load on tower top
- $e$  :eccentricity of  $R$  with respect to the center line of the top of tower
- $\Delta$  :required deflection of tower top
- $W_0, W_1, \dots, W_{r-1}$ :parts of tower weight assumed to be concentrated at the panel points indicated by the subscripts
- $R_s, R_m$  :reactions on tower at roadway level

FIGURE 18.12 Analytical model of the main tower. (Source: Birdsall, B., *Trans. ASCE*, 1942. With permission.)

### Modern Design Method

#### Finite Deformation Method

With the development of the computer in recent years, finite displacement method on framed structures has come to be used as a more accurate analytical method. This method is used for plane analysis or space frame analysis of the entire suspension bridge structure. The frame analysis according to the finite displacement theory is performed by obtaining the relation between the force and the displacement at the ends of each element of the entire structural system. In this analytical method, the actual behavior of the bridge such as elongation of the hanger ropes, which is disregarded in the deflection theory, can be considered. The suspension bridges with inclined hanger ropes, such as the Severn Bridge, and bridges in the erection stage are also analyzed by the theory. While the relation between force and displacement at the ends of the element is nonlinear in the finite displacement theory, the linearized finite deformation theory is used in the analysis of the eccentric vertical load and the out-of-plane analysis; because the geometric nonlinearity can be considered to be relatively small in those cases.

#### Elastic Buckling and Vibration Analyses

Elastic buckling analysis is used to determine an effective buckling length that is needed in the design of the compression members, such as the main tower shafts. Vibration analysis is needed to determine the natural frequency and vibrational modes of the entire suspension bridge as part of the design of wind and seismic resistance. Both of these analyses are eigenvalue problems in the linearized finite deformation method for framed structures.

### 18.3.3 Design Criteria

#### Design Procedure

A general design procedure for a suspension bridge superstructure is shown in Figure 18.13. Most rational structure for a particular site is selected from the result of preliminary design over various alternatives. Then final detailed design proceeds.

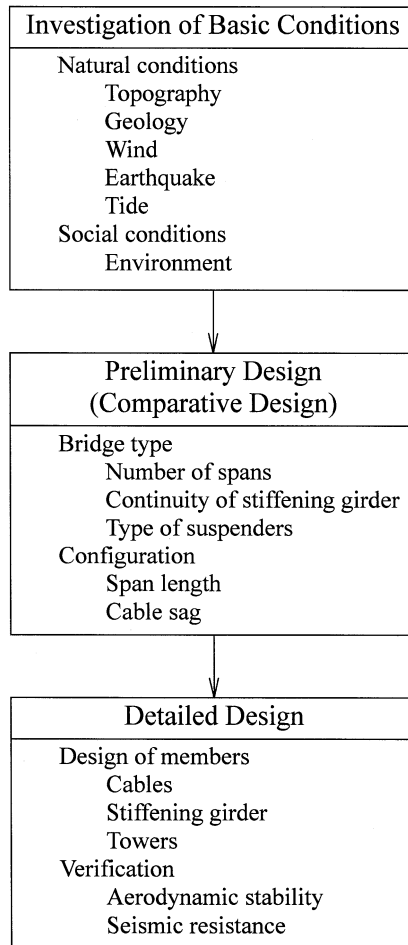

**FIGURE 18.13** Design procedure for the superstructure of a suspension bridge.

## Design Load

Design loads for a suspension bridge must take into consideration the natural conditions of the construction site, the importance of a bridge, its span length, and its function (vehicular or railway traffic). It is important in the design of suspension bridges to determine the dead load accurately because the dead load typically dominates the forces on the main components of the bridge. Securing structural safety against strong winds and earthquakes is also an important issue for long-span suspension bridges.

1. In the case of wind, consideration of the vibrational and aerodynamic characteristics is extremely important.
2. In the case of earthquake, assumption of earthquake magnitude and evaluation of energy content are crucial for bridges in regions prone to large-scale events.

Other design loads include effects due to errors in fabrication and erection of members, temperature change, and possible movement of the supports.

## Analysis Procedure

General procedure used for the design of a modern suspension bridge is as follows (Figure 18.14):

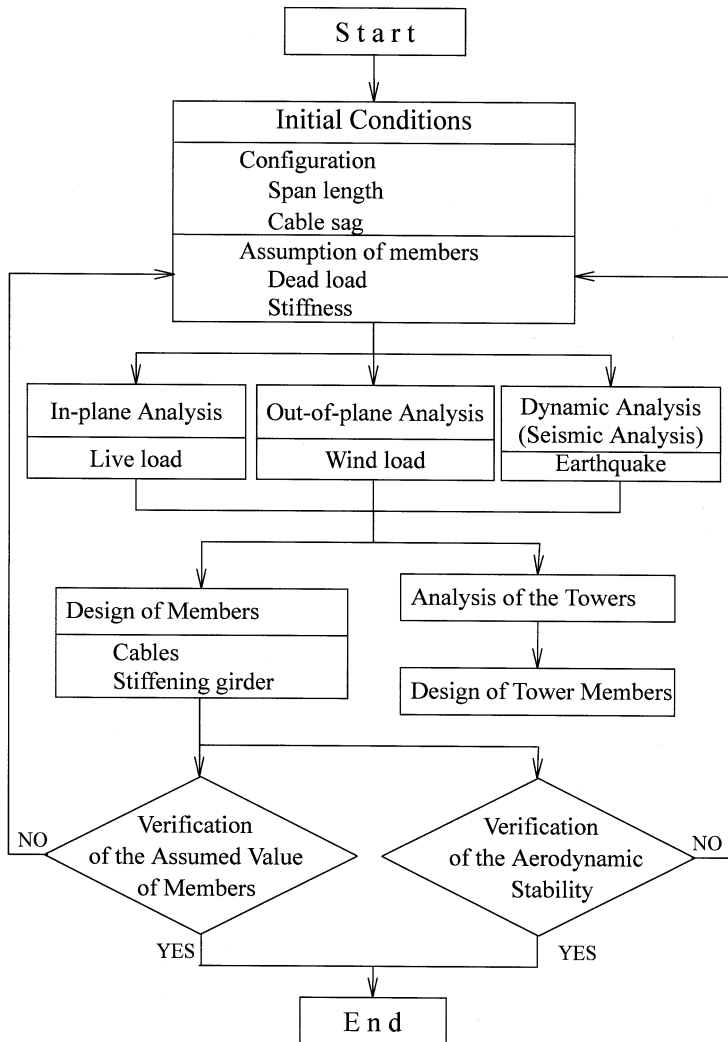

FIGURE 18.14 General procedure for designing a suspension bridge.

1. *Select Initial Configuration:* Span length and cable sag are determined, and dead load and stiffness are assumed.
2. *Analysis of the Structural Model:* In the case of in-plane analysis, the forces on and deformations of members under live load are obtained by using finite deformation theory or linear finite deformation theory with a two-dimensional model. In the case of out-of-plane analysis, wind forces on and deformations of members are calculated by using linear finite deformation theory with a three-dimensional model.
3. *Dynamic Response Analysis:* The responses of earthquakes are calculated by using response spectrum analysis or time-history analysis.
4. *Member Design:* The cables and girders are designed using forces obtained from previous analyses.
5. *Tower Analysis:* The tower is analyzed using loads and deflection, which are determined from the global structure analysis previously described.
6. *Verification of Assumed Values and Aerodynamic Stability:* The initial values assumed for dead load and stiffness are verified to be sufficiently close to those obtained from the detailed analysis. Aerodynamic stability is to be investigated through analyses and/or wind tunnel tests using dimensions obtained from the dynamic analysis.

## 18.3.4 Wind-Resistant Design

### General

In the first half of the 19th century, suspension bridges occasionally collapsed under wind loads because girders tended to have insufficient rigidity. In the latter half of the 19th century, such collapses decreased because the importance of making girders sufficiently stiff was recognized.

In the beginning of the 20th century, stiffening girders with less rigidity reappeared as the deflection theory was applied to long-span suspension bridges. The Tacoma Narrows Bridge collapsed 4 months after its completion in 1940 under a wind velocity of only 19 m/s. The deck of the bridge was stiffened with I-girders formed from built-up plates. The I-girders had low rigidity and aerodynamic stability was very inferior as shown in recent wind-resistant design. After this accident, wind tunnel tests for stiffening girders became routine in the investigation of aerodynamic stability. Truss-type stiffening girders, which give sufficient rigidity and combined partially with open deck grating, have dominated the design of modern suspension bridges in the United States.

A new type of stiffening girder, however, a streamlined box girder with sufficient aerodynamic stability was adopted for the Severn Bridge in the United Kingdom in 1966 [16,17]. In the 1980s, it was confirmed that a box girder, with big fairings (stabilizers) on each side and longitudinal openings on upper and lower decks, had excellent aerodynamic stability. This concept was adopted for the Tsing Ma Bridge, completed in 1997 [18]. The Akashi Kaikyo Bridge has a vertical stabilizer in the center span located along the centerline of the truss-type stiffening girder just below the deck to improve aerodynamic stability [19].

In the 1990s, in Italy, a new girder type has been proposed for the Messina Straits Bridge, which would have a center span of 3300 m [20]. The 60-m-wide girder would be made up of three oval box girders which support the highway and railway traffic. Aerodynamic dampers combined with wind screens would also be installed at both edges of the girder. Stiffening girders in recent suspension bridges are shown in Figure 18.15.

### Design Standard

Figure 18.16 shows the wind-resistant design procedure specified in the Honshu–Shikoku Bridge Standard [21]. In the design procedure, wind tunnel testing is required for two purposes: one is to verify the airflow drag, lift, and moment coefficients which strongly influences the static design; and the other is to verify that harmful vibrations would not occur.

### Analysis

Gust response analysis is an analytical method to ascertain the forced vibration of the structure by wind gusts. The results are used to calculate structural deformations and stress in addition to those caused by mean wind. Divergence, one type of static instability, is analyzed by using finite displacement analysis to examine the relationship between wind force and deformation. Flutter is the most critical phenomenon in considering the dynamic stability of suspension bridges, because of the possibility of collapse. Flutter analysis usually involves solving the motion equation of the bridge as a complex eigenvalue problem where unsteady aerodynamic forces from wind tunnel tests are applied.

### Wind Tunnel Testing

In general, the following wind tunnel tests are conducted to investigate the aerodynamic stability of the stiffening girder.

1. Two-Dimensional Test of Rigid Model with Spring Support: The aerodynamic characteristics of a specific mode can be studied. The scale of the model is generally higher than  $1/100$ .
2. Three-Dimensional Global Model Test: Test used to examine the coupling effects of different modes.



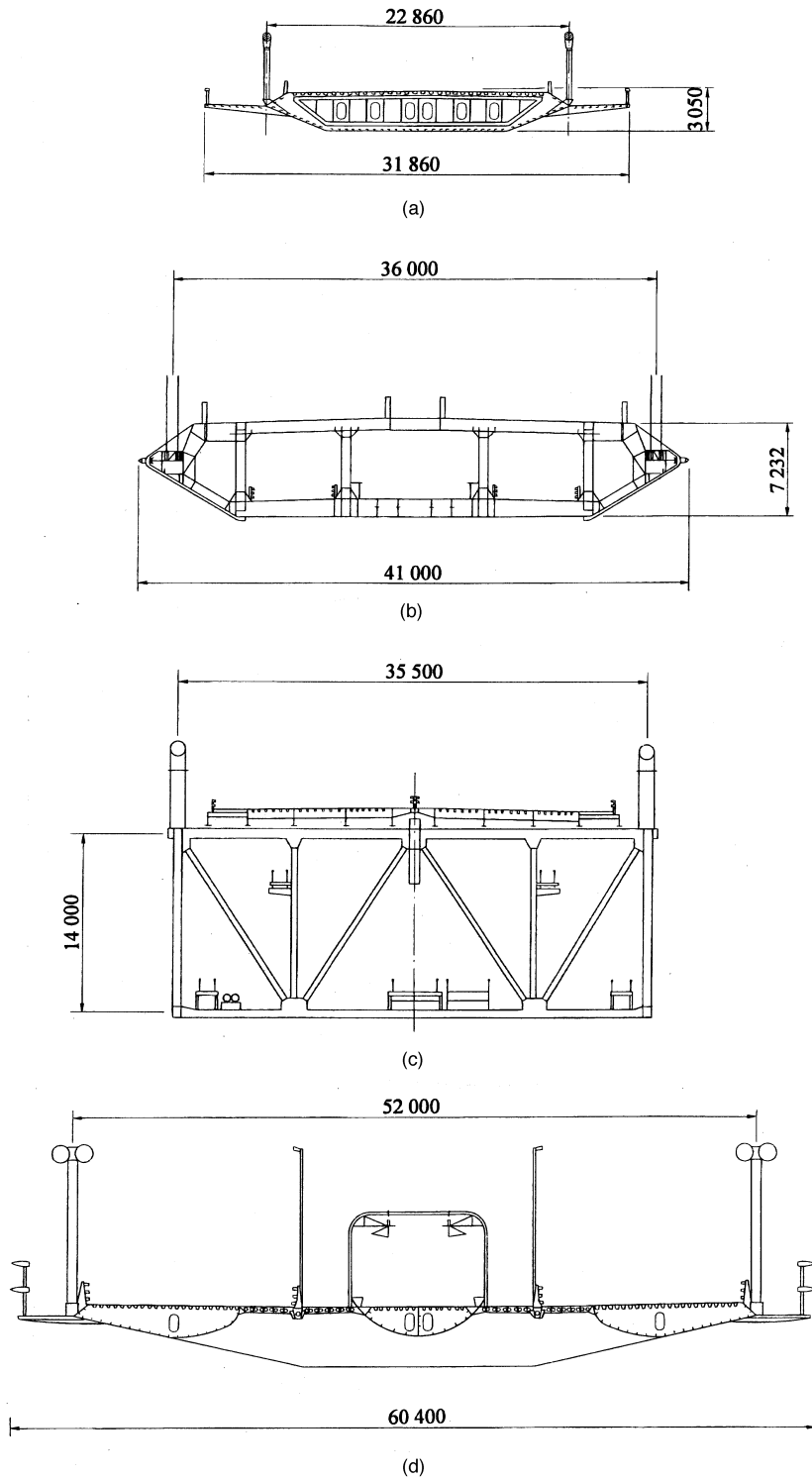

**FIGURE 18.15** Cross sections through stiffening girders. (a) Severn Bridge, (b) Tsing Ma Bridge; (c) Akashi Kaikyo Bridge, (d) Messina Straits Bridge.

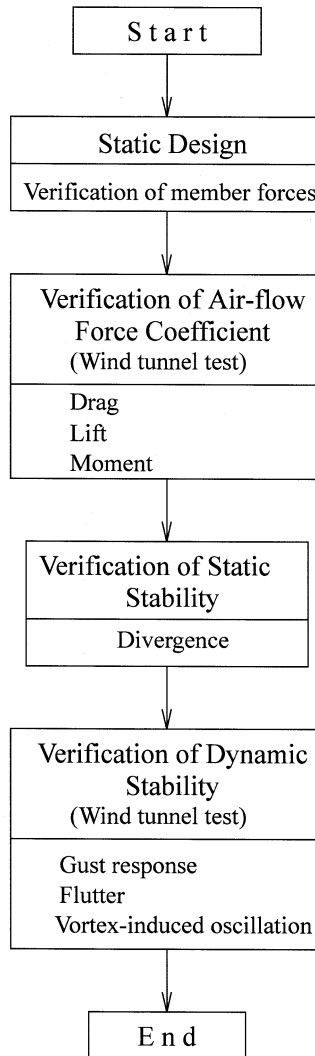

**FIGURE 18.16** Procedure for wind-resistant design. (Source: Honshu-Shikoku Bridge Authority, Wind-Resistant Design Standard for the Akashi Kaikyo Bridge, HSBA, Japan, 1990. With permission.)

For the Akashi Kaikyo Bridge, a global  $1/100$  model about 40 m in total length, was tested in a boundary layer wind tunnel laboratory. Together with the verification of the aerodynamic stability of the Akashi Kaikyo Bridge, new findings in flutter analysis and gust response analysis were established from the test results.

### Countermeasures against Vibration

Countermeasures against vibration due to wind are classified as shown in [Table 18.4](#).

1. *Increase Structural Damping*: Damping, a countermeasure based on structural mechanics, is effective in decreasing the amplitude of vortex-induced oscillations which are often observed during the construction of the main towers and so on. Tuned mass dampers (TMD) and tuned liquid dampers (TLD) have also been used to counter this phenomenon in recent years. Active mass dampers (AMD), which can suppress vibration amplitudes over a wider frequency band, have also been introduced.

**TABLE 18.4** Vibration Countermeasures

Category	Item	Countermeasures
Structural mechanics	Increase damping	TMD, <sup>a</sup> TLD, <sup>b</sup> AMD <sup>c</sup>
	Increase rigidity	Increase cross-sectional area of girder
	Increase mass	
Aerodynamic mechanics	Cross section	Streamlined box girder Open deck
	Supplements	Spoiler, Flap

<sup>a</sup> Tuned mass damper.

<sup>b</sup> Tuned liquid damper.

<sup>c</sup> Active mass damper.

2. *Increase Rigidity*: One way to increase rigidity is to increase the girder height. This is an effective measure for suppressing flutter.
3. *Aerodynamic Mechanics*: It may also be necessary to adopt aerodynamic countermeasures, such as providing openings in the deck, and supplements for stabilization in the stiffening girder.

### 18.3.5 Seismic Design

#### General

In recent years, there are no cases of suspension bridges collapsing or even being seriously damaged due to earthquakes. During construction of the Akashi Kaikyo Bridge, the relative location of four foundations changed slightly due to crustal movements in the 1995 Hyogo-ken Nanbu Earthquake. Fortunately, the earthquake caused no critical damage to the structures. Although the shear forces in the superstructure generated by a seismic load are relatively small due to the natural frequency of the superstructure being generally low, it is necessary to consider possible large displacements of the girders and great forces transferring to the supports.

#### Design Method

The superstructure of a suspension bridge should take into account long-period motion in the seismic design. A typical example of a seismic design is as follows. The superstructure of the Akashi Kaikyo Bridge was designed with consideration given to large ground motions including the long-period contribution. The acceleration response spectrum from the design standard is shown in [Figure 18.17 \[22\]](#). Time-history analysis was conducted on a three-dimensional global bridge model including substructures and ground springs.

### 18.3.6 Main Towers

#### General

Flexible-type towers have predominated among main towers in recent long-span suspension bridges. This type of tower maintains structural equilibrium while accommodating displacement and the downward force from the main cable. Both steel and concrete are feasible material. Major bridges like the Golden Gate Bridge and the Verrazano Narrows Bridge in the United States as well as the Akashi Kaikyo Bridge in Japan consist of steel towers. Examples of concrete towers include the Humber and Great Belt East Bridges in Europe and the Tsing Ma Bridge in China. Because boundary conditions and loading of main towers are straightforward in suspension bridge systems, the main tower can be analyzed as an independent structural system.

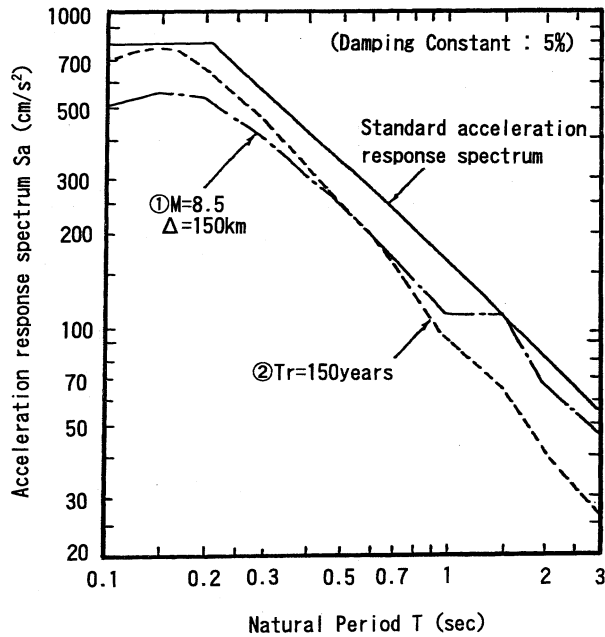

FIGURE 18.17 Design acceleration response spectrum. (Source: Honshu–Shikoku Bridge Authority, Seismic Design Standard for the Akashi Kaikyo Bridge, Japan, 1988. With permission.)

## Design Method

The design method for steel towers follows. The basic concepts for design of concrete towers are similar. For the transverse direction, main towers are analyzed using small deformation theory. This is permissible because the effect of cable restraint is negligible and the flexural rigidity of the tower is high. For the longitudinal direction, Birdsall's analysis method, discussed in Section 18.3.2, is generally used. However, more rigorous methods, such as finite displacement analysis with a three-dimensional model which allows analysis of both the transverse and longitudinal directions, can be used, as was done in the Akashi Kaikyo Bridge. An example of the design procedure for main towers is shown in Figure 18.18 [23].

## Tower Structure

The tower shaft cross section may be T-shaped, rectangular, or cross-shaped, as shown in Figure 18.19. Although the multicell made up of small box sections has been used for some time, cells and single cells have become noticeable in more recent suspension bridges.

The details of the tower base that transmits the axial force, lateral force, and bending moment into the foundation, are either of grillage (bearing transmission type) or embedded types (shearing transmission type), as shown in Figure 18.20. Field connections for the tower shaft are typically bolted joints. Large compressive forces from the cable act along the tower shafts. Tight contact between two metal surfaces acts together with bolted joint to transmit the compressive force across joints with the bearing stresses spread through the walls and the longitudinal stiffeners inside the tower shaft. This method can secure very high accuracy of tower configuration. Another type of connection detail for steel towers using tension bolts was used in the Forth Road Bridge, the Severn Bridge, the Bosphorus Bridge, and the first Kurushima Kaikyo Bridge (Figure 18.21).

### 18.3.7 Cables

#### General

Parallel wire cable has been used exclusively as the main cable in long-span suspension bridges. Parallel wire has the advantage of high strength and high modulus of elasticity compared with

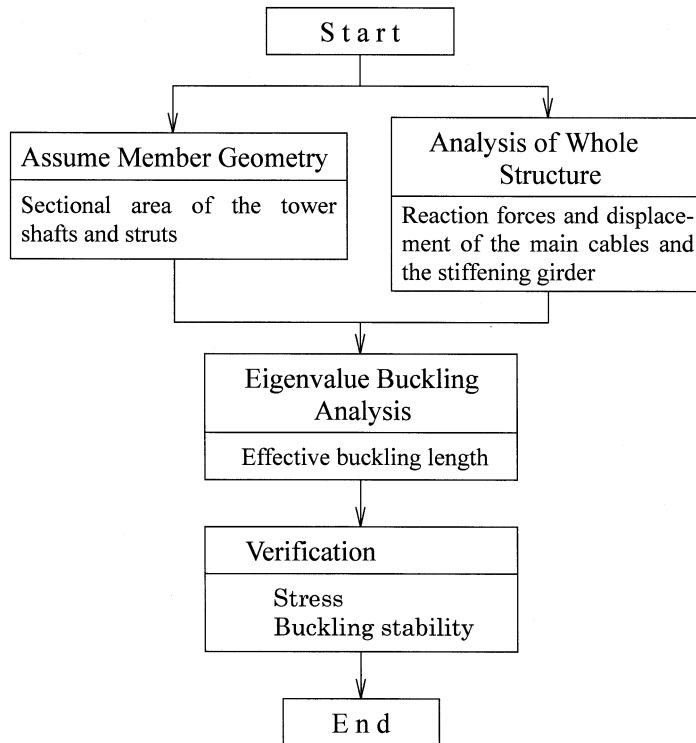

FIGURE 18.18 Design procedure for the main towers. (Source: Honshu–Shikoku Bridge Authority, Design Standard of the Main Tower for a Suspension Bridge, HSBA, Japan, 1984. With permission.)

stranded wire rope. The design of the parallel wire cable is discussed next, along with structures supplemental to the main cable.

### Design Procedure

Alignment of the main cable must be decided first (Figure 18.22). The sag–span ratios should be determined in order to minimize the construction costs of the bridge. In general, this sag–span ratio is around 1:10. However, the vibration characteristics of the entire suspension bridge change occasionally with changes in the sag–span ratios, so the influence on the aerodynamic stability of the bridge should be also considered. After structural analyses are executed according to the design process shown in Figure 18.14, the sectional area of the main cable is determined based on the maximum cable tension, which usually occurs at the side span face of the tower top.

### Design of Cable Section

The tensile strength of cable wire has been about  $1570 \text{ N/mm}^2$  ( $160 \text{ kgf/mm}^2$ ) in recent years. For a safety factor, 2.5 was used for the Verrazano Narrows Bridge and 2.2 for the Humber Bridge, respectively. In the design of the Akashi Kaikyo Bridge, a safety factor of 2.2 was used using the allowable stress method considering the predominant stress of the dead load. The main cables used a newly developed high-strength steel wire whose tensile strength is  $1770 \text{ N/mm}^2$  ( $180 \text{ kgf/mm}^2$ ) and the allowable stress was  $804 \text{ N/mm}^2$  ( $82 \text{ kgf/mm}^2$ ) which led to this discussion. Increase in the strength of cable wire over the years is shown in Figure 18.23. In the design of the Great Belt East Bridge which was done using limit state design methods, a safety factor of 2.0 was applied for the critical limit state [24]. Cable statistics of major suspension bridges are shown in Table 18.5.

### Supplemental Components

Figure 18.24 shows the supplemental components of the main cable.

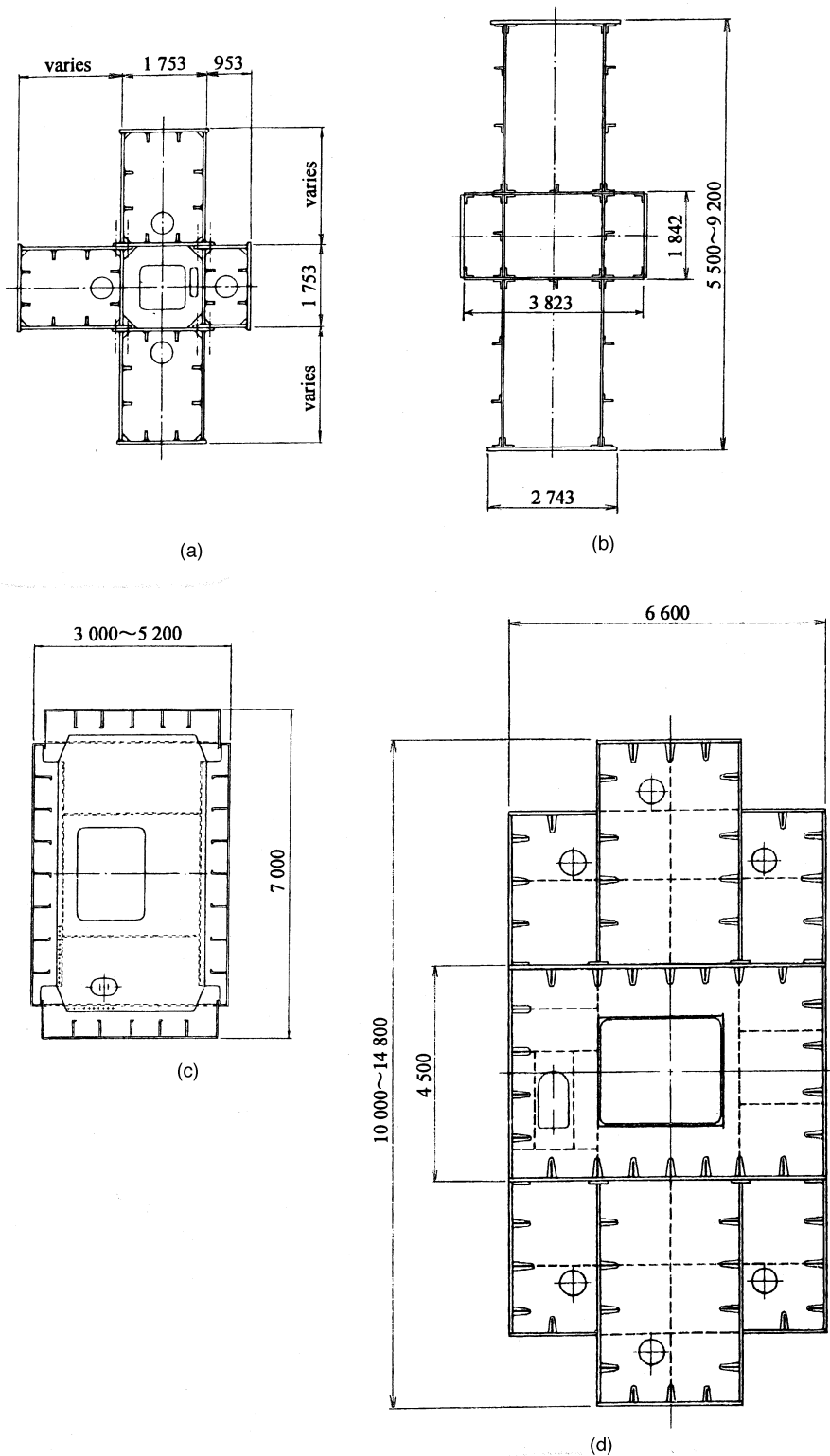

**FIGURE 18.19** Tower shaft section. (a) New Port Bridge, (b) 25de Abril Bridge, (c) Bosphorus Bridge, (d) Akashi Kaikyo Bridge.

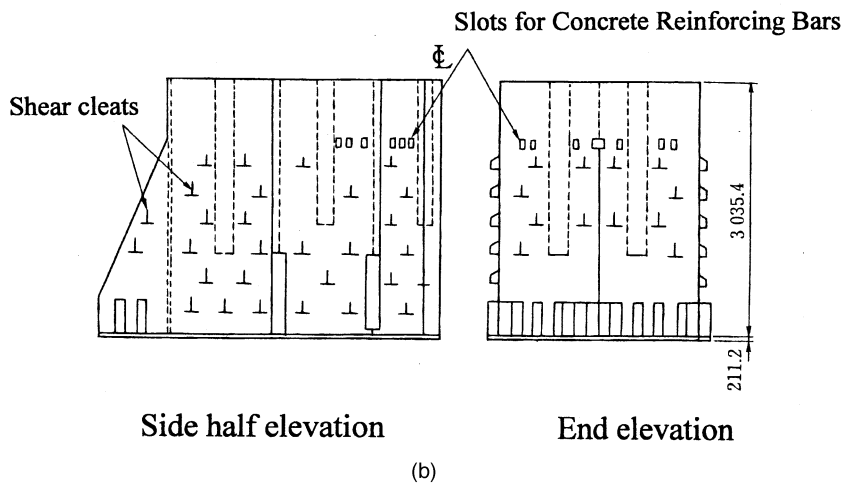
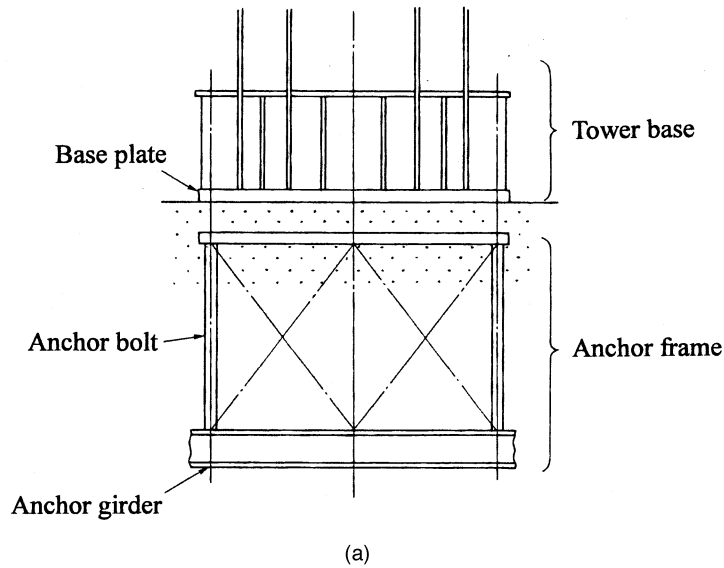

**FIGURE 18.20** Tower base. (a) Grillage structure (bearing — transmission type), Akashi Kaikyo Bridge; (b) embedded base (shearing transmission type), Bosphorus Bridge.

1. Cable strands are anchored in the cable anchor frame which is embedded into the concrete anchorage.
2. Hanger ropes are fixed to the main cable with the cable bands.
3. Cable saddles support the main cable at the towers and at the splay bents in the anchorages; the former is called the tower saddle and the latter is called the splay saddle.

### 18.3.8 Suspended Structures

#### General

The suspended structure of a suspension bridge can be classified as a truss stiffening girder or a box stiffening girder, as described in Section 18.3.4. Basic considerations in selecting girder types are shown in Table 18.6. The length of the bridge and the surrounding natural conditions are also factors.

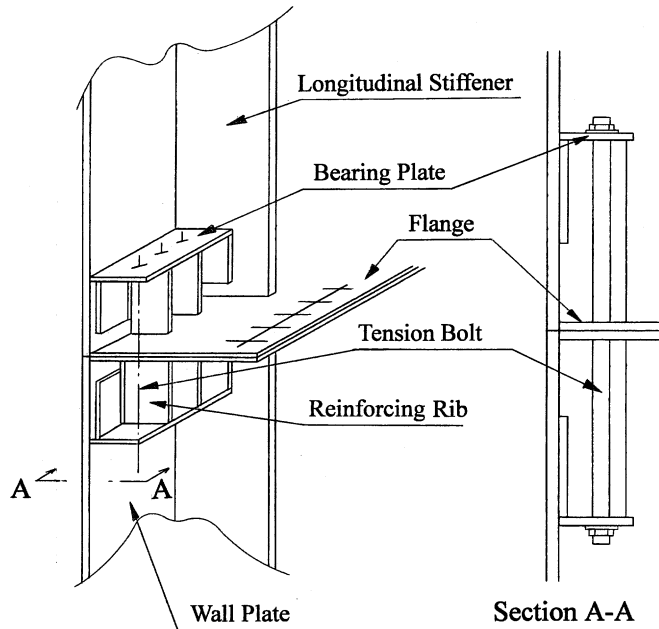
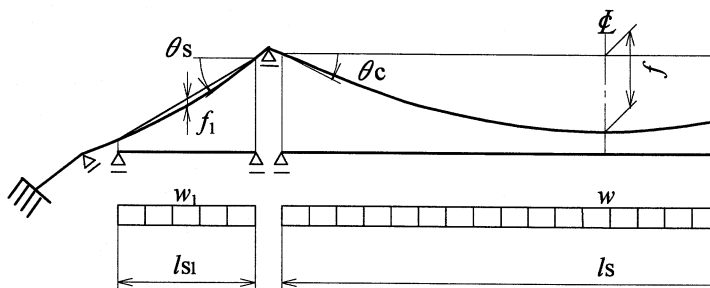

FIGURE 18.21 Connection using tension bolts. (First Kurushima Kaikyo Bridge, Bosphorus Bridge.)



- |                                       |  |
|---------------------------------------|--|
| $f$ : Center span sag                 | $\theta_c$ : Tangential angle of cable (Center span) |
| $f_1$ : Side span sag                 | $\theta_s$ : Tangential angle of cable (Side span)   |
| $w$ : Uniform dead load (Center span) | $l_s$ : Center span length                           |
| $w_1$ : Uniform dead load (Side span) | $l_{s1}$ : Side span length                          |

FIGURE 18.22 Configuration of suspension bridge.

## Design of the Stiffening Girder

### Basic Dimensions

The width of the stiffening girder is determined to accommodate carriageway width and shoulders. The depth of the stiffening girder, which affects its flexural and torsional rigidity, is decided so as to ensure aerodynamic stability. After examining alternative stiffening girder configurations, wind tunnel tests are conducted to verify the aerodynamic stability of the girders.

In judging the aerodynamic stability, in particular the flutter, of the bridge design, a bending–torsional frequency ratio of 2.0 or more is recommended. However, it is not always necessary to satisfy this condition if the aerodynamic characteristics of the stiffening girder are satisfactory.



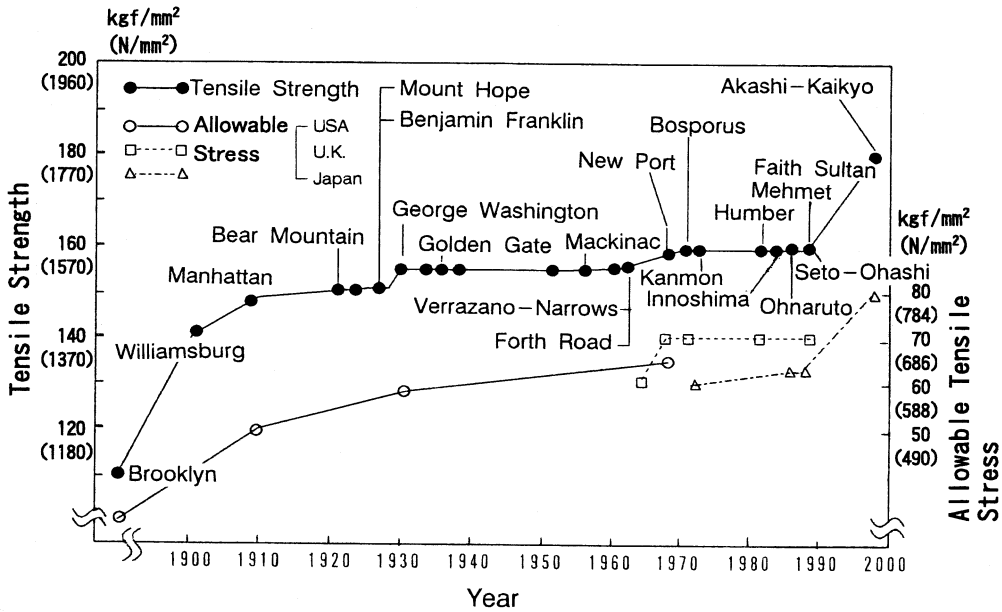

FIGURE 18.23 Increase in strength of cable wire. (Source: Honshu-Shikoku Bridge Authority, Akashi Kaikyo Bridge — Engineering Note, Japan, 1992. With permission.)

TABLE 18.5 Main Cable of Long-Span Suspension Bridges

No.	Bridge	Country	Year of Completion	Center Span Length (m)	Erection Method <sup>c</sup>	Composition of Main Cable <sup>d</sup>
1	Akashi Kaikyo	Japan	1998	1991	P.S.	127 × 290
2	Great Belt East	Denmark	1998	1624	A.S.	504 × 37
3	Humber	U.K.	1981	1410	A.S.	404 × 37
4	Jing Yin Yangtze River	China <sup>a</sup>	(1999) <sup>b</sup>	1385	P.S.	127 × 169(c/s), 177(s/s)
5	Tsing Ma	China <sup>a</sup>	1997	1377	A.S.	368 × 80 + 360 × 11 (c/s, Tsing Yi s/s) 368 × 80 + 360 × 11 + 304 × 6 (Ma Wan s/s)
6	Verrazano Narrows	U.S.	1964	1298.5	A.S.	428 × 61 × 2 cables
7	Golden Gate	U.S.	1937	1280.2	A.S.	452 × 61
8	Höga Kusten	Sweden	1997	1210	A.S.	304 × 37(c/s) 304 × 37 + 120 × 4(s/s)
9	Mackinac Straits	U.S.	1957	1158.2	A.S.	340 × 37
10	Minami Bisan-Seto	Japan	1988	1100	P.S.	127 × 271
11	Fatih Sultan Mehmet	Turkey	1988	1090	A.S.	504 × 32(c/s), 36(s/s)
12	Bosphorus	Turkey	1973	1074	A.S.	550 × 19
13	George Washington	U.S.	1931	1066.8	A.S.	434 × 61 × 2 cables
14	3rd Kurushima Kaikyo	Japan	1999 <sup>b</sup>	1030	P.S.	127 × 102
15	2nd Kurushima Kaikyo	Japan	1999 <sup>b</sup>	1020	P.S.	127 × 102
16	25 de Abril	Portugal	1966	1012.9	A.S.	304 × 37
17	Forth Road	UK	1964	1005.8	A.S.	(304~328) × 37
18	Kita Bisan-Seto	Japan	1988	990	P.S.	127 × 234
19	Severn	UK	1966	987.6	A.S.	438 × 19
20	Shimotsui-Seto	Japan	1988	940	A.S.	552 × 44

<sup>a</sup> The People's Republic of China.

<sup>b</sup> Under construction

<sup>c</sup> P.S.: prefabricated parallel wire strand method A.S.: aerial spinning erection method.

<sup>d</sup> Wire/strand × strand/cable.

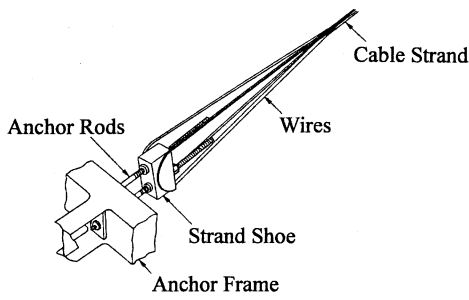

AS method

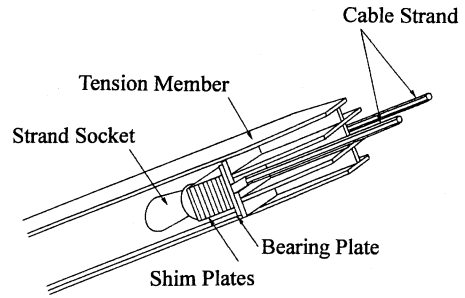

PS method

(a)

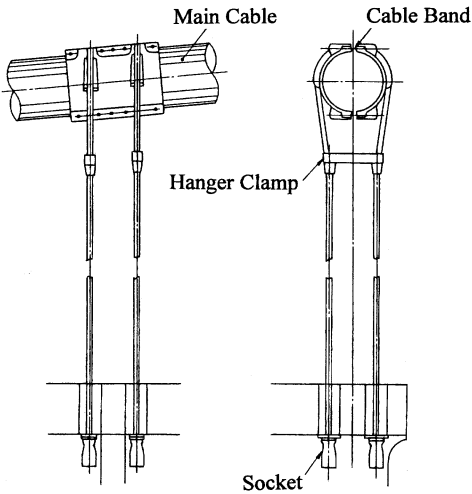

Bearing connection

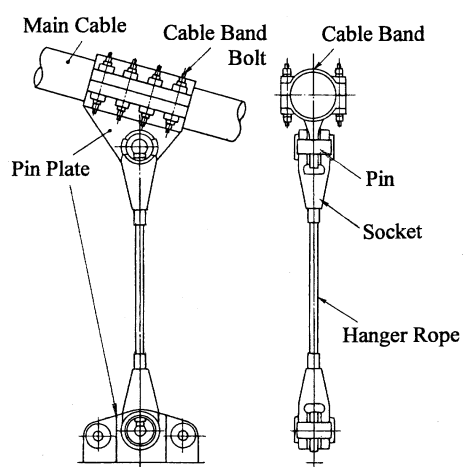

Pin plate connection

(b)

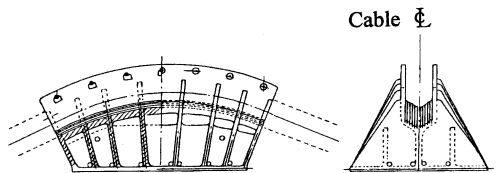

Side elevation

End elevation

Tower saddle

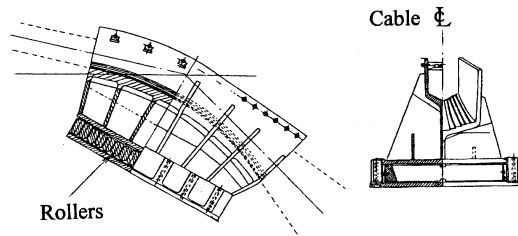

Side elevation

End elevation

Splay saddle

(c)

**FIGURE 18.24** Supplemental components of the main cable. (a) Strand anchorage of the anchor frame. (Source: Japan Society of Civil Engineers, *Suspension Bridge*, Japan, 1996. With permission.) (b) Hanger ropes. (Source: Japan Society of Civil Engineers, *Suspension Bridge*, Japan, 1996. With permission.) (c) Cable Saddles. (Source: Honshu-Shikoku Bridge Authority, *Design of a Suspension Bridge*, Japan, 1990. With permission.)

**TABLE 18.6** Basic Considerations in Selecting Stiffening Structure Types

Item	Truss Girder	Box Girder
Girder height	High	Low
Aerodynamic stability	Flutter should be verified	Vortex-induced oscillation tends to occur Flutter should be verified
Maintenance	Coating area is large	Coating area is small
Construction	Both plane section and section erection methods can be used	Only section erection method is permissible

### Truss Girders

The design of the sectional properties of the stiffening girder is generally governed by the live load or the wind load. Linear finite deformation theory is commonly applied to determine reactions due to live loads in the longitudinal direction, in which theory the influence line of the live load can be used. The reactions due to wind loads, however, are decided using finite deformation analysis with a three-dimensional model given that the stiffening girder and the cables are loaded with a homogeneous part of the wind load. Linearized finite deformation theory is used to calculate the out-of-plane reactions due to wind load because the change in cable tension is negligible.

### Box Girders

The basic dimensions of a box girder for relatively small suspension bridges are determined only by the requirements of fabrication, erection, and maintenance. Aerodynamic stability of the bridge is not generally a serious problem. The longer the center span becomes, however, the stiffer the girder needs to be to secure aerodynamic stability. The girder height is determined to satisfy the rigidity requirement. For the Second and Third Kurushima Kaikyo Bridges, the girder height required was set at 4.3 m based on wind tunnel tests. Fatigue due to live loads needs to be especially considered for the upper flange of the box girder because it directly supports the bridge traffic. The diaphragms support the floor system and transmit the reaction force from the floor system to the hanger ropes.

### Supplemental Components

Figure 18.25 shows supplemental components of the stiffening girder.

1. The stay ropes fix the main cable and the girder to restrict longitudinal displacement of the girder due to wind, earthquake, and temperature changes.
2. The tower links and end links support the stiffening girder at the main tower and the anchorages.
3. The wind bearings, which are installed in horizontal members of the towers and anchorages, prevent transverse displacement of the girders due to wind and earthquakes.
4. Expansion joints are installed at the main towers of two-hinged bridges and at the anchorages to absorb longitudinal displacement of the girder.

## 18.4 Construction

### 18.4.1 Main Towers

Suspension bridge tower supports the main cable and the suspended structure. Controlling erection accuracy to ensure that the tower shafts are perpendicular is particularly important. During construction, because the tower is cantilevered and thus easily vibrates due to wind, countermeasures for vibration are necessary. Recent examples taken from constructing steel towers of the Akashi Kaikyo Bridge and concrete towers of the Tsing Ma Bridge are described below.

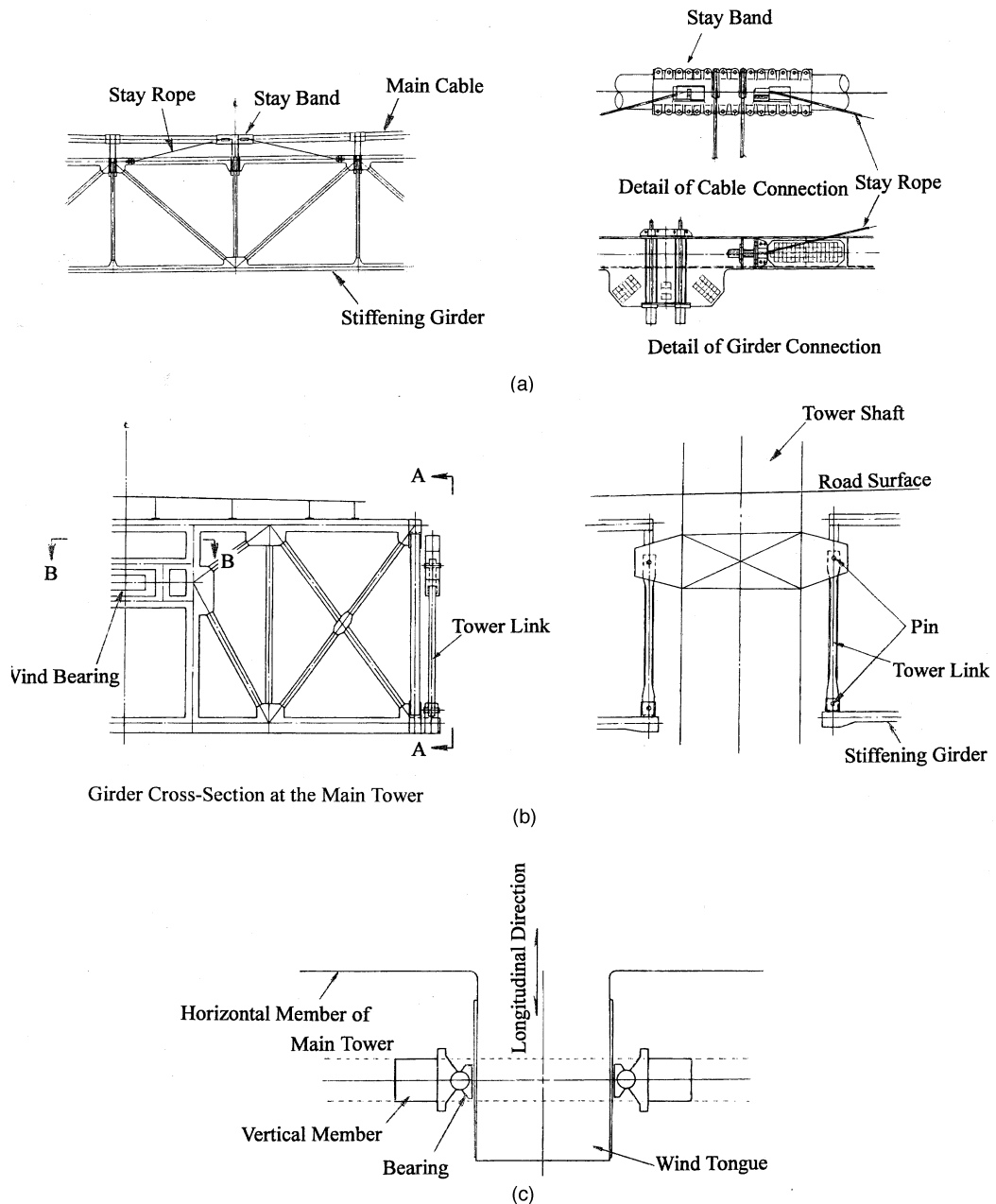

**FIGURE 18.25** Supplemental components of the stiffening girder. (a) Center stay; (b) tower link (Section A-A); (c) wind bearing (Section B-B). (Source: Honshu-Shikoku Bridge Authority, Design of a Suspension Bridge, Japan, 1990. With permission.)

### Steel Towers

Steel towers are typically either composed of cells or have box sections with rib stiffening plates. The first was used in the Forth Road Bridge, the 25 de Abril Bridge, the Kanmon Bridge, and most of the Honshu-Shikoku Bridges. The latter was applied in the Severn Bridge, the Bosphorus Bridge, the Fatih Sultan Mehmet Bridge, and the Kurushima Kaikyo Bridges. For the erection of steel towers,

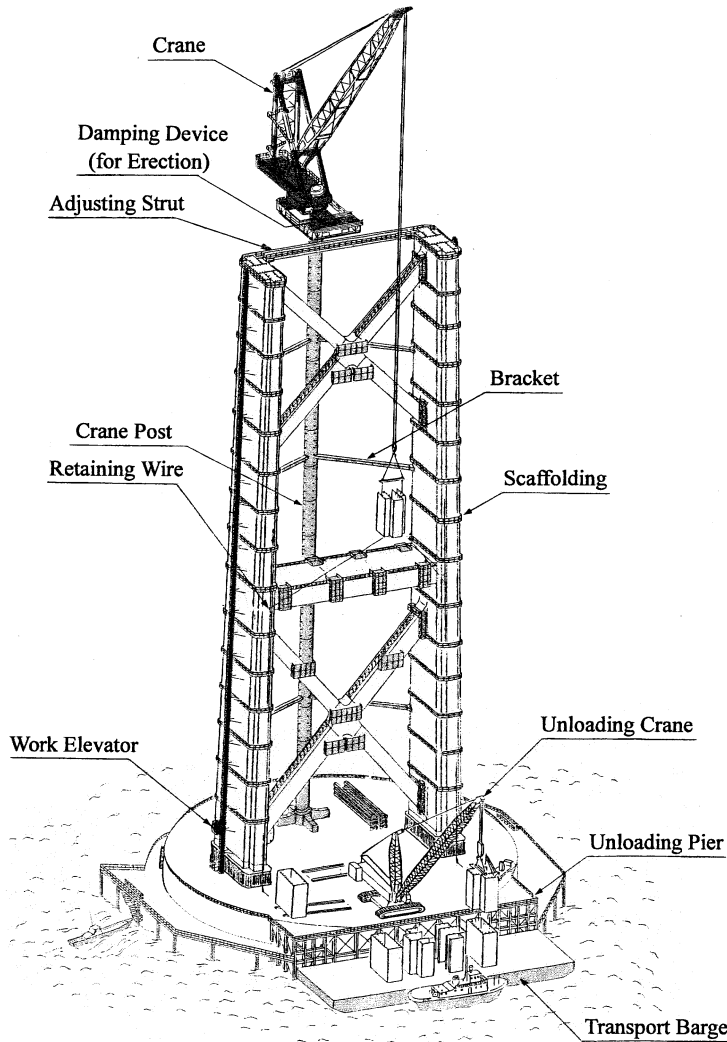

**FIGURE 18.26** Overview of main tower construction. (Source: Honshu–Shikoku Bridge Authority, Akashi Kaikyo Bridge — Engineering Note, Japan, 1992. With permission.)

floating, tower, and creeper traveler cranes are used. [Figure 18.26](#) shows the tower erection method used for the Akashi Kaikyo Bridge. The tower of the Akashi Kaikyo Bridge is 297 m high. The cross section consists of three cells with clipped corners (see [Figure 18.19](#)). The shaft is vertically divided into 30 sections. The sections were prefabricated and barged to the site. The base plate and the first section was erected using a floating crane. The remainder was erected using a tower crane supported on the tower pier. To control harmful wind-induced oscillations, TMD and AMD were installed in the tower shafts and the crane.

### Concrete Towers

The tower of the Tsing Ma Bridge is 206 m high, 6.0 m in width transversely, and tapered from 18.0 m at the bottom to 9.0 m at the top longitudinally. The tower shafts are hollow. Each main tower was slip-formed in a continuous around-the-clock operation, using two tower cranes and concrete buckets ([Figure 18.27](#)).



FIGURE 18.27 Tower erection for the Tsing Ma Bridge. (Courtesy of Mitsui Engineering & Shipbuilding Co., Ltd.)

## 18.4.2 Cables

### Aerial Spinning Method

The aerial spinning method (AS method) of parallel wire cables was invented by John A. Roebling and used for the first time in the Niagara Falls Bridge which was completed in 1855 with a center span of 246 m (Figure 18.28). He established this technology in the Brooklyn Bridge where steel wire was first used. Most suspension bridges built in the United States since Roebling's development of the AS method have used parallel wire cables. In contrast, in Europe, the stranded rope cable was used until the Forth Road Bridge was built in 1966.

In the conventional AS method, individual wires were spanned in free-hang condition, and the sag of each wire had to be individually adjusted to ensure all were of equal length. In this so-called sag-control method, the quality of the cables and the erection duration are apt to be affected by site working conditions, including wind conditions and the available cable-spinning equipment. It also requires a lot of workers to adjust the sag of the wires.

A new method, called the tension-control method, was developed in Japan (Figure 18.29). The idea is to keep the tension in the wire constant during cable spinning to obtain uniform wire lengths. This method was used on the Hirado, Shimotsui–Seto, Second Bosphorus, and Great Belt East Bridges (Figure 18.30). It does require adjustment of the individual strands even in this method.

### Prefabricated Parallel Wire Strand Method

Around 1965, a method of prefabricating parallel wire cables was developed to cut the on-site work intensity required for the cable spinning in the AS method. The prefabricated parallel wire strand method (PS method) was first used in the New Port Bridge. That was the first step toward further progress achieved in Japan in enlarging strand sections, developing high-tensile wire, and lengthening the strand.

## 18.4.3 Suspended Structures

There are various methods of erecting suspended structures. Typically, they have evolved out of the structural type and local natural and social conditions.

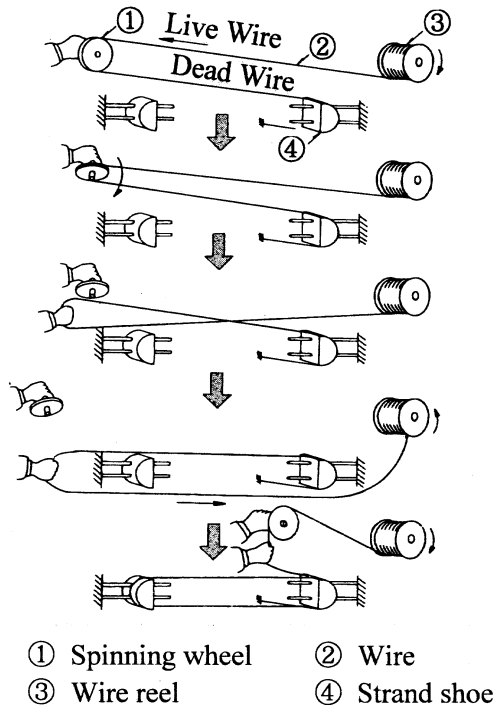

FIGURE 18.28 Operating principle of aerial spinning. (Source: Honshu–Shikoku Bridge Authority, Technology of Seto–Ohashi Bridge, Japan, 1989. With permission.)

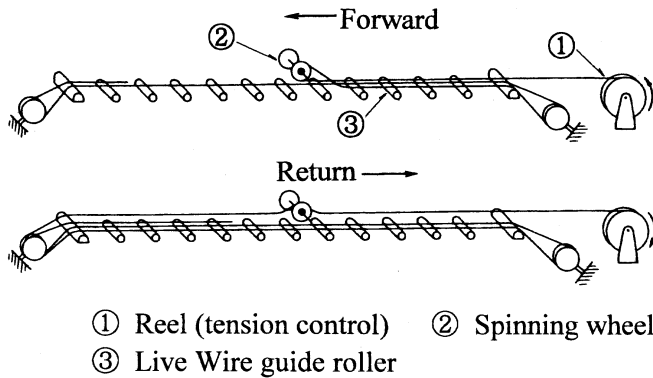

FIGURE 18.29 Operating principle of tension control method. (Source: Honshu–Shikoku Bridge Authority, Technology of Set–Ohashi Bridge, Japan, 1989. With permission.)

### Girder Block Connection Methods

The connections between stiffening girder section may be classified as one of two methods.

#### All Hinge Method

In this method the joints are loosely connected until all girder sections are in place in general. This method enables simple and easy analysis of the behavior of the girders during construction. Any temporary reinforcement of members is usually unnecessary. However, it is difficult to obtain enough aerodynamic stability unless structures to resist wind force are given to the joints which were used in the Kurushima Kaikyo Bridges, for example.



**FIGURE 18.30** Aerial spinning for the Shimotsui-Seto bridge. (Courtesy of Honshu-Shikoku Bridge Authority.)

#### Rigid Connection Method

In this method full-splice joints are immediately completed as each girder block is erected into place. This keeps the stiffening girder smooth and rigid, providing good aerodynamic stability and high construction accuracy. However, temporary reinforcement of the girders and hanger ropes to resist transient excessive stresses or controlled operation to avoid overstress are sometimes required.

#### Girder Erection Methods

Stiffening girders are typically put in place using either the girder-section method or cantilevering from the towers or the anchorages.

##### Girder-Section Method

The state of the art for the girder-section method with hinged connections is shown in [Figure 18.31](#). At the Kurushima Kaikyo Bridges construction sites, the fast and complex tidal current of up to 5 m/s made it difficult for the deck barges and tugboats to maintain their desired position for a long time. As a result, a self-controlled barge, able to maintain its position using computer monitoring, and a quick joint system, which can shorten the actual erection period, were developed and fully utilized.

##### Cantilevering Method

A recent example of the cantilevering method of girders on the Akashi Kaikyo Bridge is shown in [Figure 18.32](#). Preassembled panels of the stiffening girder truss were erected by extending the stiffening girders as a cantilever from the towers and anchorages. This avoided disrupting marine traffic, which would have been required for the girder-section method.

## 18.5 Field Measurement and Coatings

---

### 18.5.1 Loading Test

The purpose of loading tests is chiefly to confirm the safety of a bridge for both static and dynamic behavior. Static loading tests were performed on the Wakato, the Kanmon, and the President Mobutu





**FIGURE 18.31** Block erection method on the Kurushima Kaikyo Bridge. (Courtesy of Honshu–Shikoku Bridge Authority.)



**FIGURE 18.32** Cantilevering method in the Akashi Kaikyo Bridge. (Courtesy of Honshu–Shikoku Bridge Authority.)

Sese–Seko Bridges by loading heavy vehicles on the bridges. Methods to verify dynamic behavior include vibration tests and the measurement of micro-oscillations caused by slight winds. The former test is based on the measured response to a forced vibration. The latter is described in Section 18.5.2. Dynamic characteristics of the bridge, such as structural damping, natural frequency, and mode of vibration, are ascertained using the vibration test. As the real value of structural damping is difficult to estimate theoretically, the assumed value should be verified by an actual measurement. Examples of measured data on structural damping obtained through vibration tests are shown in [Table 18.7](#).

**TABLE 18.7** Structural Damping Obtained from Vibration Tests

Bridge	Center Span Length (m)	Logarithmic Decrement <sup>a</sup>
Minami Bisan–Seto	1100	0.020 ~ 0.096
Ohnaruto	876	0.033 ~ 0.112
Kanmon	712	0.016 ~ 0.062
Ohshima	560	0.017 ~ 0.180

<sup>a</sup> Structural damping.

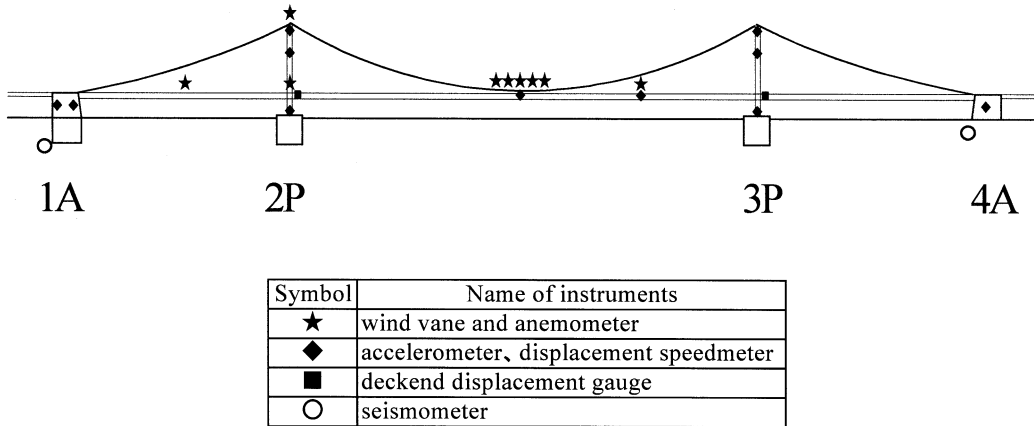

**FIGURE 18.33** Placement of measuring instruments in the Akashi Kaikyo Bridge. (Source: Abe, K. and Amano, K., Monitoring system of the Akashi Kaikyo Bridge, *Honshi Tech. Rep.*, 86, 29, 1998. With permission.)

## 18.5.2 Field Observations

Field observations are undertaken to verify such characteristics of bridge behavior as aerodynamic stability and seismic resistance, and to confirm the safety of the bridge. To collect the necessary data for certification, various measuring instruments are installed on the suspension bridge. Examples of measuring instruments used are given in [Figure 18.33](#) [25]. A wind vane and anemometer, which measure local wind conditions, and a seismometer, to monitor seismic activity, gather data on natural conditions. An accelerometer and a displacement speedometer are installed to measure the dynamic response of the structure to wind and earthquake loads. A deck end displacement gauge tracks the response to traffic loads. The accumulated data from these measuring instruments will contribute to the design of yet-longer-span bridges in the future.

## 18.5.3 Coating Specification

Steel bridges usually get a coating regimen which includes a rust-preventive paint for the base coat, and a long oil-base alkyd resin paint or chlorinated rubber resin paint for the intermediate and top coats. This painting regimen needs to be repeated at several-year intervals. Because long-span suspension bridges are generally constructed in a marine environment, which is severely corrosive, and have enormous painting surfaces, which need to be regularly redone, a heavy-duty coating method with long-term durability is required. The latest coating technology adopted for major suspension bridges is shown in [Table 18.8](#). Previous painting methods relied on oil-base anticorrosive paints or red lead anticorrosive paints for base coats with phthalic resin or aluminum paints as intermediate and top coats. The latest coating specification aimed at long-term durability calls for an inorganic zinc-enriched base

**TABLE 18.8** Coating Systems of Major Suspension Bridges

Country	Bridge	Year of Completion	Coating Specification
U.S.	George Washington	1931	Base: oil-based anticorrosive paint Top: phthalic resin paint
	San Francisco–Oakland Bay	1936	Base: red lead anticorrosive paint
	Golden Gate	1937	To: oil-modified phenolic resin aluminum paint
	Mackinac Straits	1957	Base: oil-based anticorrosive paint
Canada	Verrazano Narrows	1965	Top: phthalic resin paint
	Pierre La Porte	1970	Base: basic lead chromate anticorrosive paint Top: alkyd resin paint
Turkey	Bosphorus	1973	Base: zinc spraying Top: phenolic resin micaceous iron oxide paint
	Fatih Sultan Mehmet	1988	Base: organic zinc rich paint Intermediate: epoxy resin paint Intermediate: epoxy resin micaceous iron oxide paint Top: paint chlorinated rubber resin paint
U.K.	Forth Road	1964	Base: zinc spraying
	Severn	1966	Top: phenolic resin micaceous iron oxide paint
	Humber	1981	
Japan	Kanmon	1973	Base: zinc spraying Intermediate: micaceous iron oxide paint Top: chlorinated rubber resin paint
	Innoshima	1983	Base: hi-build inorganic zinc rich paint Intermediate: hi-build epoxy resin paint Top: polyurethane resin paint
	Akashi Kaikyo	1998	Base: hi-build inorganic zinc rich paint Intermediate: hi-build epoxy resin paint Intermediate: epoxy resin paint Top: fluororesin paint

paint, which is highly rust-inhibitive due to the sacrificial anodic reaction of the zinc, with an epoxy resin intermediate coat and a polyurethane resin or fluororesin top coat. Because the superiority of fluororesin paint for long-term durability and in holding a high luster under ultraviolet rays has been confirmed in recent years, it was used for the Akashi Kaikyo Bridge [26].

#### 18.5.4 Main Cable Corrosion Protection

Since the main cables of a suspension bridge are the most important structural members, corrosion protection is extremely important for the long-term maintenance of the bridge. The main cables are composed of galvanized steel wire about 5 mm in diameter with a void of about 20% which is longitudinally and cross-sectionally consecutive. Main cable corrosion is caused not only by water and ion invasion from outside, but also by dew resulting from the alternating dry and humid conditions inside the cable void. The standard corrosion protection system for the main cables ever since it was first worked out for the Brooklyn Bridge has been to use galvanized wire covered with a paste, wrapped with galvanized soft wires and then coated.

New approaches such as wrapping the wires with neoprene rubber or fiberglass acrylic or S-shaped deformed steel wires have also been attempted. A dehumidified air-injection system was developed and used on the Akashi Kaikyo Bridge [27]. This system includes wrapping to improve watertightness and the injection of dehumidified air into the main cables as shown in Figure 18.34. Examples of a corrosion protection system for the main cables in major suspension bridges are shown in Table 18.9.

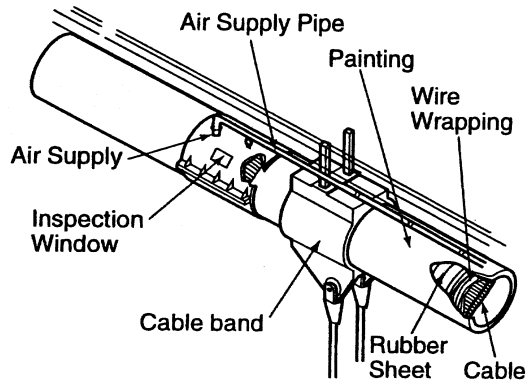

FIGURE 18.34 Dehumidified air-injection system for the main cables of the Akashi Kaikyo Bridge. (Courtesy of Honshu-Shikoku Bridge Authority.)

TABLE 18.9 Corrosion Protection Systems for Main Cable of Major Suspension Bridges

Bridge	Year of Completion	Erection Method	Cable			Wrapping
			Wire	Paste		
Brooklyn	1883	A.S.	Galvanized	Red lead paste		Galvanized wire
Williamsburg	1903	A.S.	— <sup>a</sup>	Red lead paste		Cotton duck + sheet iron coating
Golden Gate	1937	A.S.	Galvanized	Red lead paste		Galvanized wire
Chesapeake Bay II	1973	A.S.	Galvanized	—		Neoprene rubber
Verrazano Narrows	1964	A.S.	Galvanized	Red lead paste		Galvanized wire
Severn	1966	A.S.	Galvanized	Red lead paste		Galvanized wire
New Port	1969	A.S.	Galvanized	—		Glass-reinforced acrylic
Kanmon	1973	P.S.	Galvanized	Polymerized organic lead paste		Galvanized wire
Minami Bisan-Seto	1988	P.S.	Galvanized	Calcium plumbate contained polymerized organic lead paste		Galvanized wire
Hakucho	1998	P.S.	Galvanized	Aluminum triphosphate contained organic lead paste		Galvanized wire (S shape)
Akashi Kaikyo	1998	P.S.	Galvanized	—		Galvanized wire + rubber wrapping

<sup>a</sup> Coated with a raw linseed oil.

## References

1. Lu, J., Large Suspension Bridges in China, *Bridge Foundation Eng.*, 7, 20, 1996 [in Japanese].
2. Navier, M., *Papport et Mémoire sur les Ponts Suspendus*, de l'Imprimerie Royale, Paris, 1823.
3. Rankine, W. J. M., *A Manual of Applied Mechanics*, 1858.
4. Ritter, W., *Versteifungsfachwerke bei Bogen und Hängebrücken*, *Z. bauwesen*, 1877.
5. Lévy, M., *Mémoire sur le calcul des ponts suspendus rigides*, *Ann. Ponts Chaussées*, 1886.
6. Melan, J., *Theorie der eisernen Bogenbrücken und der Hängebrücken*, *Handb. Ingenieurwissensch.*, 1888.
7. Moisseiff, L. S., The towers, cables and stiffening trusses of the bridge over the Delaware River between Philadelphia and Camden, *J. Franklin Inst.*, Oct., 1925.

8. Moisseiff, L. S. and Lienhard, F., Suspension bridge under the action of lateral forces, *Trans. ASCE*, 58, 1933.
9. Brotton, D. M., Williamson, N. M., and Millar, M., The solution of suspension bridge problems by digital computers, Part I, *Struct. Eng.*, 41, 1963.
10. Brotton, D. M., A general computer programme for the solution of suspension bridge problems, *Struct. Eng.*, 44, 1966.
11. Saafan, A. S., Theoretical analysis of suspension bridges, *Proc. ASCE*, 92, ST4, 1966.
12. Tezcan, S. S., Stiffness analysis of suspension bridges by iteration, in *Symposium on Suspension Bridges*, Lisbon, 1966.
13. Bleich, F., McCullough, C. B., Rosecrans, R., and Vincent, G. S., The Mathematical Theory of Vibration in Suspension Bridges, Department of Commerce, *Bureau of Public Roads*, Washington, D.C., 1950.
14. Birdsall, B., The suspension bridge tower cantilever problem, *Trans. ASCE*, 1942.
15. Steinman, D. B., A generalized deflection theory for suspension bridges, *Trans. ASCE*, 100, 1935.
16. Walshe, D. E. et al., A Further Aerodynamic Investigation for the Proposed Severn River Suspension Bridge, 1966.
17. Roberts, G., Severn Bridge, Institution of Civil Engineers, London, 1970.
18. Simpson, A. G., Curtis, D. J., and Choi, Y.-L., Aeroelastic aspects of the Lantau fixed crossing, Institution of Civil Engineers, London, 1981.
19. Ohashi, M., Miyata, T., Okauchi, I., Shiraishi, N., and Narita, N., Consideration for Wind Effects on a 1990 m Main Span Suspension Bridge, Pre-report 13th Int. Congress IABSE, 1988, 911.
20. Diana, G., Aeroelastic study of long span suspension bridges, the Messina Crossing, ASCE Structures Congress '93, Irvine, CA, 1993.
21. Honshu-Shikoku Bridge Authority, Wind-Resistant Design Standard for the Akashi Kaikyo Bridge, HSBA, Japan, 1990 [in Japanese].
22. Kashima, S., Yasuda, M., Kanazawa, K., and Kawaguchi, K., Earthquake Resistant Design of Akashi Kaikyo Bridge, paper presented as Third Workshop on Performance and Strengthening of Bridge Structures, Tsukuba, 1987.
23. Honshu-Shikoku Bridge Authority, Design Standard of the Main Tower for a Suspension Bridge, HSBA, Japan, 1984 [in Japanese].
24. Petersen, A. and Yamasaki, Y., Great Belt Bridge and design of its cable works, *Bridge Foundation Eng.*, 1, 18, 1994 [in Japanese].
25. Abe, K. and Amano, K., Monitoring System of the Akashi Kaikyo Bridge, *Honshi Technical Report*, 86, 29, 1998 [in Japanese].
26. Honshu-Shikoku Bridge Authority, Steel Bridges Coating Standards of Honshu-Shikoku Bridge, HSBA, Japan, 1990 [in Japanese].
27. Ito, M., Saeki, S., and Tatsumi, M., Corrosion protection of bridge cables: from Japanese experiences, in *Proceedings of the International Seminar on New Technologies for Bridge Management*, IABSE, Seoul, 1996.