

LRFD Design Example for Steel Girder Superstructure Bridge

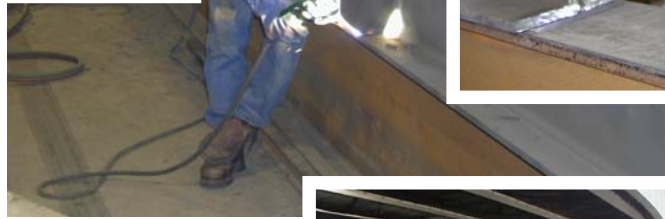

NATIONAL HIGHWAY INSTITUTE

Training Solutions for Transportation Excellence

Prepared for

**FHWA / National Highway Institute
Washington, DC**

US Units

Prepared by

**Baker
ChallengeUs.**

**Michael Baker Jr Inc
Moon Township,
Pennsylvania**

**Development of a Comprehensive Design
Example for a Steel Girder Bridge
with Commentary**

**Design Process Flowcharts for
Superstructure and Substructure Designs**

**Prepared by
Michael Baker Jr., Inc.**

November 2003

1. Report No. FHWA NHI - 04-041	2. Government Accession No.	3. Recipient's Catalog No.	
4. Title and Subtitle LRFD Design Example for Steel Girder Superstructure Bridge with Commentary		5. Report Date December 2003	
		6. Performing Organization Code	
7. Author (s) Raymond A. Hartle, P.E., Kenneth E. Wilson, P.E., S.E., William A. Amrhein, P.E., S.E., Scott D. Zang, P.E., Justin W. Bouscher, E.I.T., Laura E. Volle, E.I.T.		8. Performing Organization Report No. B25285 001 0200 HRS	
9. Performing Organization Name and Address Michael Baker Jr., Inc. Airside Business Park, 100 Airside Drive Moon Township, PA 15108		10. Work Unit No. (TRAIS)	
		11. Contract or Grant No. DTFH61-02-D-63001	
12. Sponsoring Agency Name and Address Federal Highway Administration National Highway Institute (HNHI-10) 4600 N. Fairfax Drive, Suite 800 Arlington, Virginia 22203		13. Type of Report and Period Covered Final Submission August 2002 - December 2003	
		14. Sponsoring Agency Code	
15. Supplementary Notes Baker Principle Investigator: Raymond A. Hartle, P.E. Baker Project Managers: Raymond A. Hartle, P.E. and Kenneth E. Wilson, P.E., S.E. FHWA Contracting Officer's Technical Representative: Thomas K. Saad, P.E. Team Leader, Technical Review Team: Firas I. Sheikh Ibrahim, Ph.D., P.E.			
16. Abstract <p>This document consists of a comprehensive steel girder bridge design example, with instructional commentary based on the <i>AASHTO LRFD Bridge Design Specifications</i> (Second Edition, 1998, including interims for 1999 through 2002). The design example and commentary are intended to serve as a guide to aid bridge design engineers with the implementation of the <i>AASHTO LRFD Bridge Design Specifications</i>, and is offered in both US Customary Units and Standard International Units.</p> <p>This project includes a detailed outline and a series of flowcharts that serve as the basis for the design example. The design example includes detailed design computations for the following bridge features: concrete deck, steel plate girder, bolted field splice, shear connectors, bearing stiffeners, welded connections, elastomeric bearing, cantilever abutment and wingwall, hammerhead pier, and pile foundations. To make this reference user-friendly, the numbers and titles of the design steps are consistent between the detailed outline, the flowcharts, and the design example.</p> <p>In addition to design computations, the design example also includes many tables and figures to illustrate the various design procedures and many AASHTO references. AASHTO references are presented in a dedicated column in the right margin of each page, immediately adjacent to the corresponding design procedure. The design example also includes commentary to explain the design logic in a user-friendly way. Additionally, tip boxes are used throughout the design example computations to present useful information, common practices, and rules of thumb for the bridge designer. Tips do not explain what must be done based on the design specifications; rather, they present suggested alternatives for the designer to consider. A figure is generally provided at the end of each design step, summarizing the design results for that particular bridge element.</p> <p>The analysis that served as the basis for this design example was performed using the AASHTO Opis software. A sample input file and selected excerpts from the corresponding output file are included in this document.</p>			
17. Key Words Bridge Design, Steel Girder, Load and Resistance Factor Design, LRFD, Concrete Deck, Bolted Field Splice, Hammerhead Pier, Cantilever Abutment, Wingwall, Pile Foundation		18. Distribution Statement This report is available to the public from the National Technical Information Service in Springfield, Virginia 22161 and from the Superintendent of Documents, U.S. Government Printing Office, Washington, D.C. 20402.	
19. Security Classif. (of this report) Unclassified	20. Security Classif. (of this page) Unclassified	21. No. of Pages 644	22. Price

This page intentionally left blank

ACKNOWLEDGEMENTS

We would like to express appreciation to the Illinois Department of Transportation, Washington State Department of Transportation, and Mr. Mike Grubb, BSDI, for providing expertise on the Technical Review Committee.

We would also like to acknowledge the contributions of the following staff members at Michael Baker Jr., Inc.:

Tracey A. Anderson
Jeffrey J. Campbell, P.E.
James A. Duray, P.E.
John A. Dziubek, P.E.
David J. Foremsky, P.E.
Maureen Kanfoush
Herman Lee, P.E.
Joseph R. McKool, P.E.
Linda Montagna
V. Nagaraj, P.E.
Jorge M. Suarez, P.E.
Scott D. Vannoy, P.E.
Roy R. Weil
Ruth J. Williams

Table of Contents

1. Flowcharting Conventions

2. Flowcharts

Main Flowchart

Chart 1 - General Information

Chart 2 - Concrete Deck Design

Chart 3 - Steel Girder Design

Chart 4 - Bolted Field Splice Design

Chart 5 - Miscellaneous Steel Design

Chart 6 - Bearing Design

Chart 7 - Abutment and Wingwall Design

Chart 8 - Pier Design

Chart P - Pile Foundation Design

Flowcharting Conventions

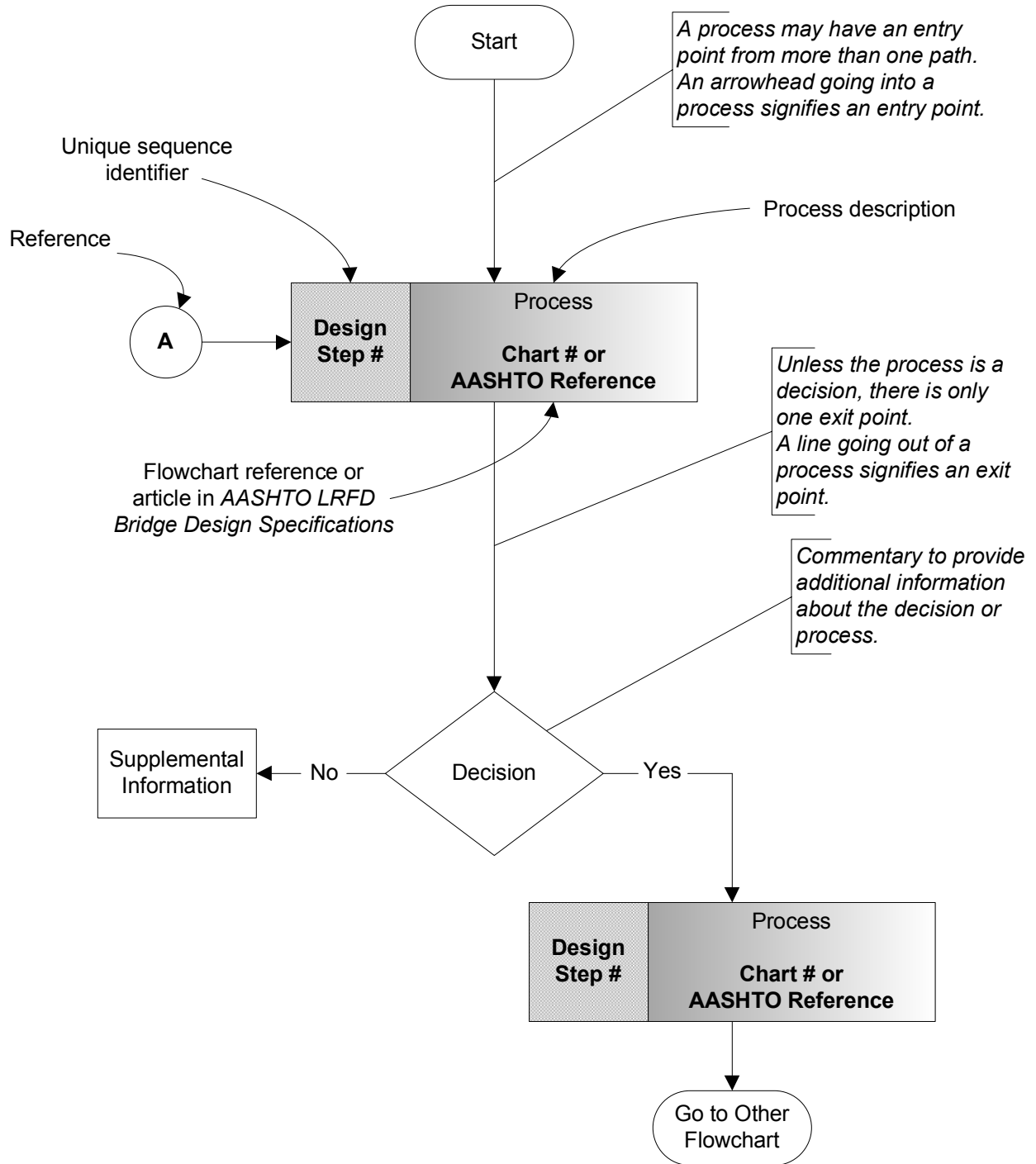

Main Flowchart

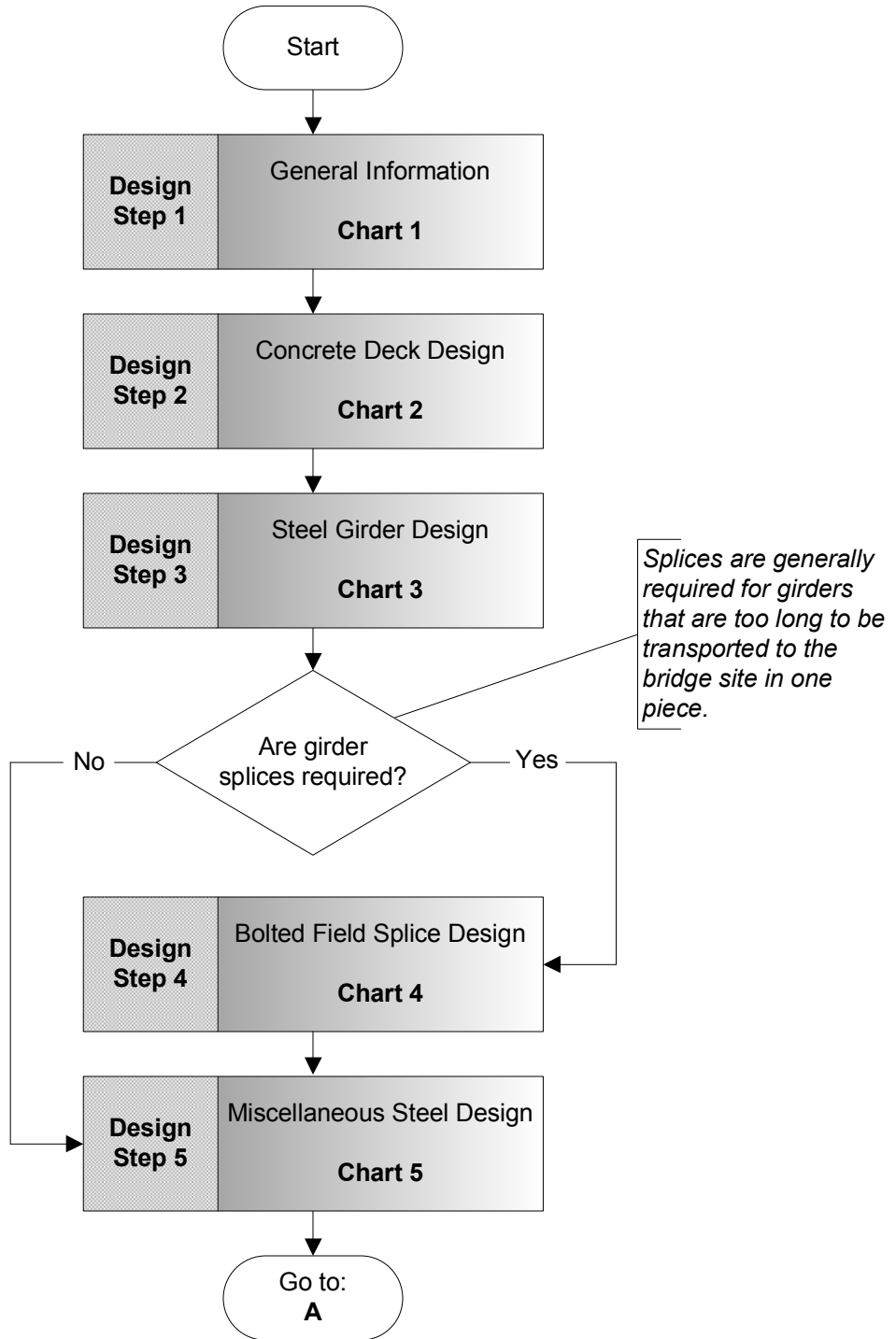

Main Flowchart (Continued)

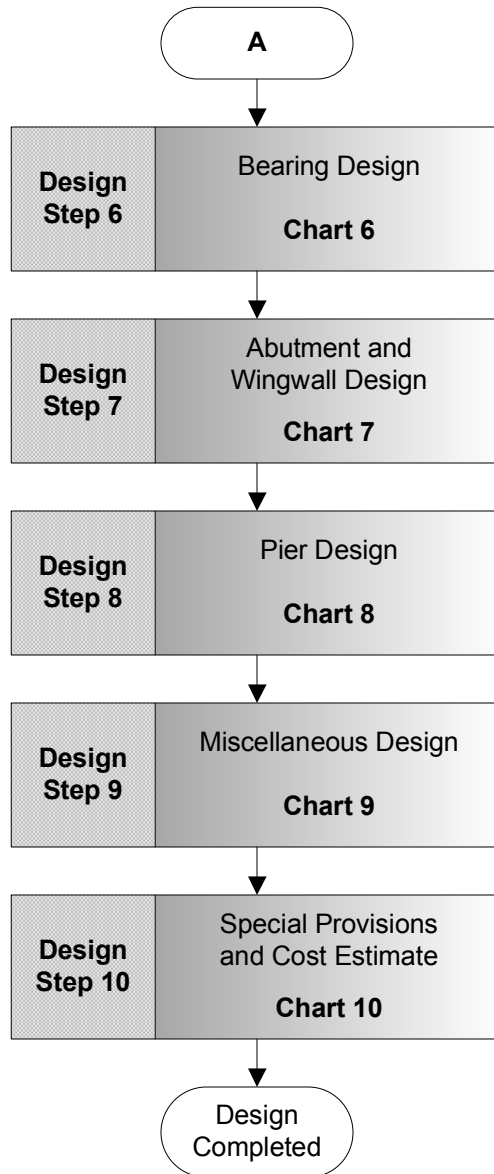

Note:
 Design Step P is used for pile foundation design for the abutments, wingwalls, or piers.

General Information Flowchart Chart 1

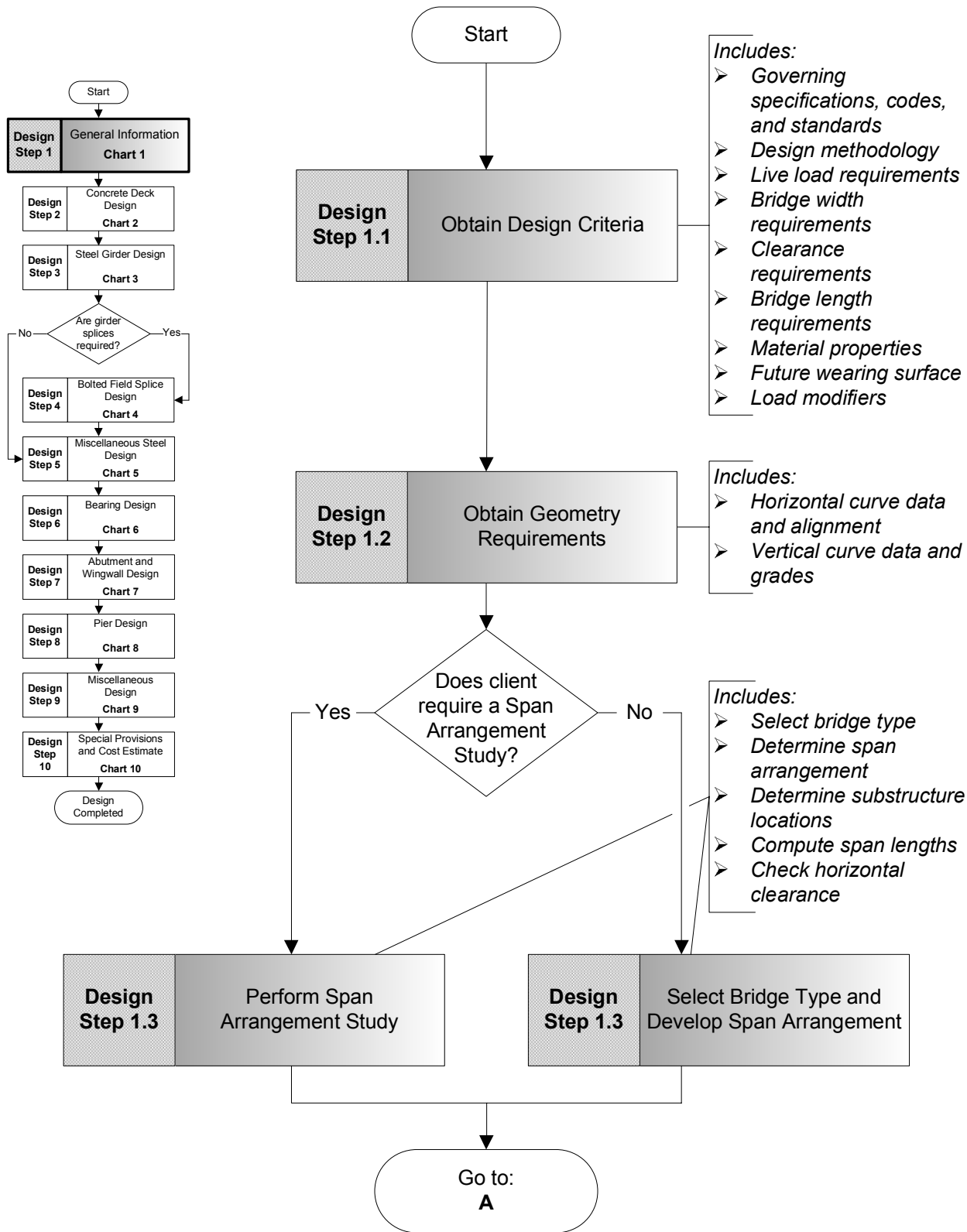

General Information Flowchart (Continued) Chart 1

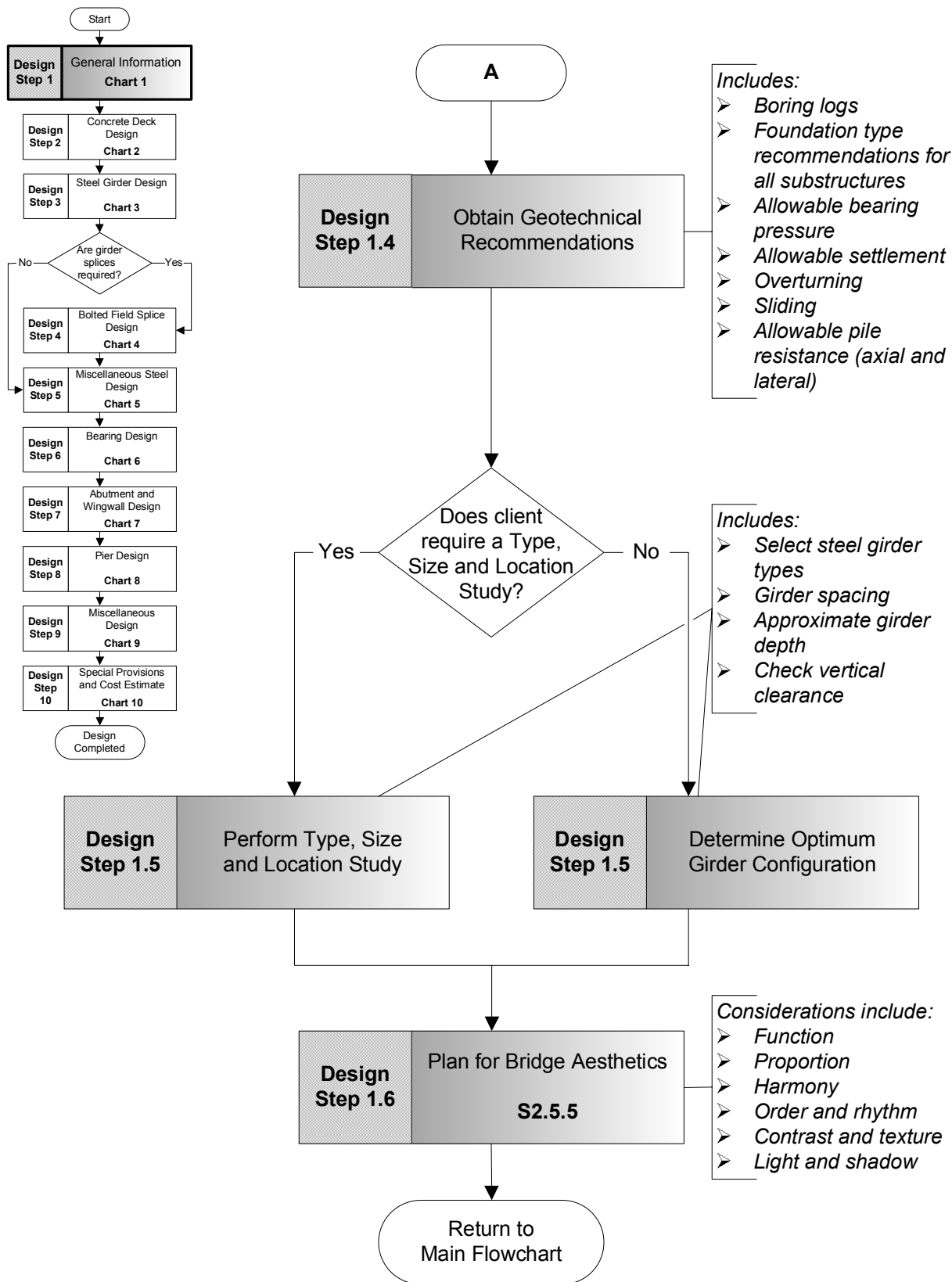

Concrete Deck Design Flowchart Chart 2

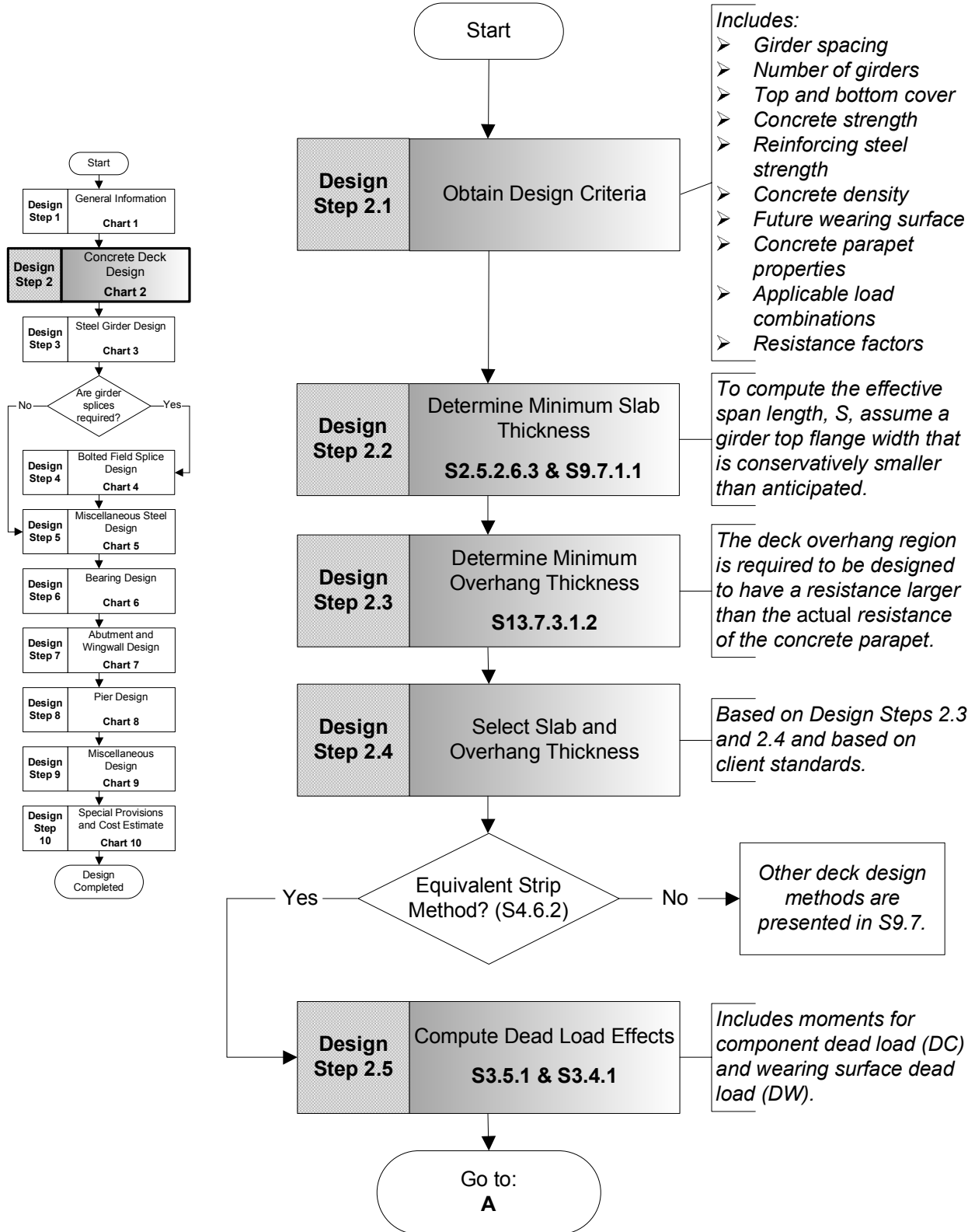

Concrete Deck Design Flowchart (Continued) Chart 2

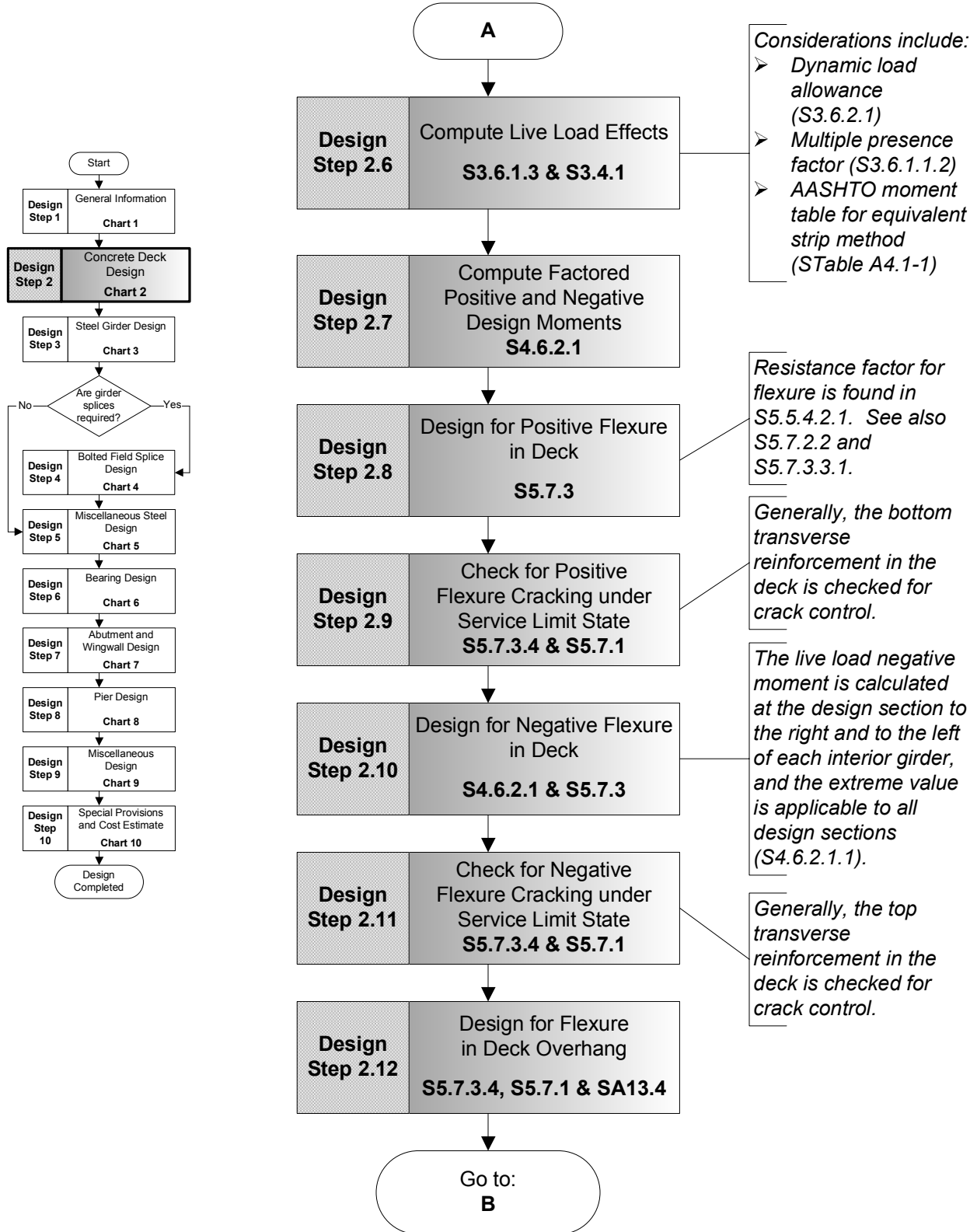

Concrete Deck Design Flowchart (Continued) Chart 2

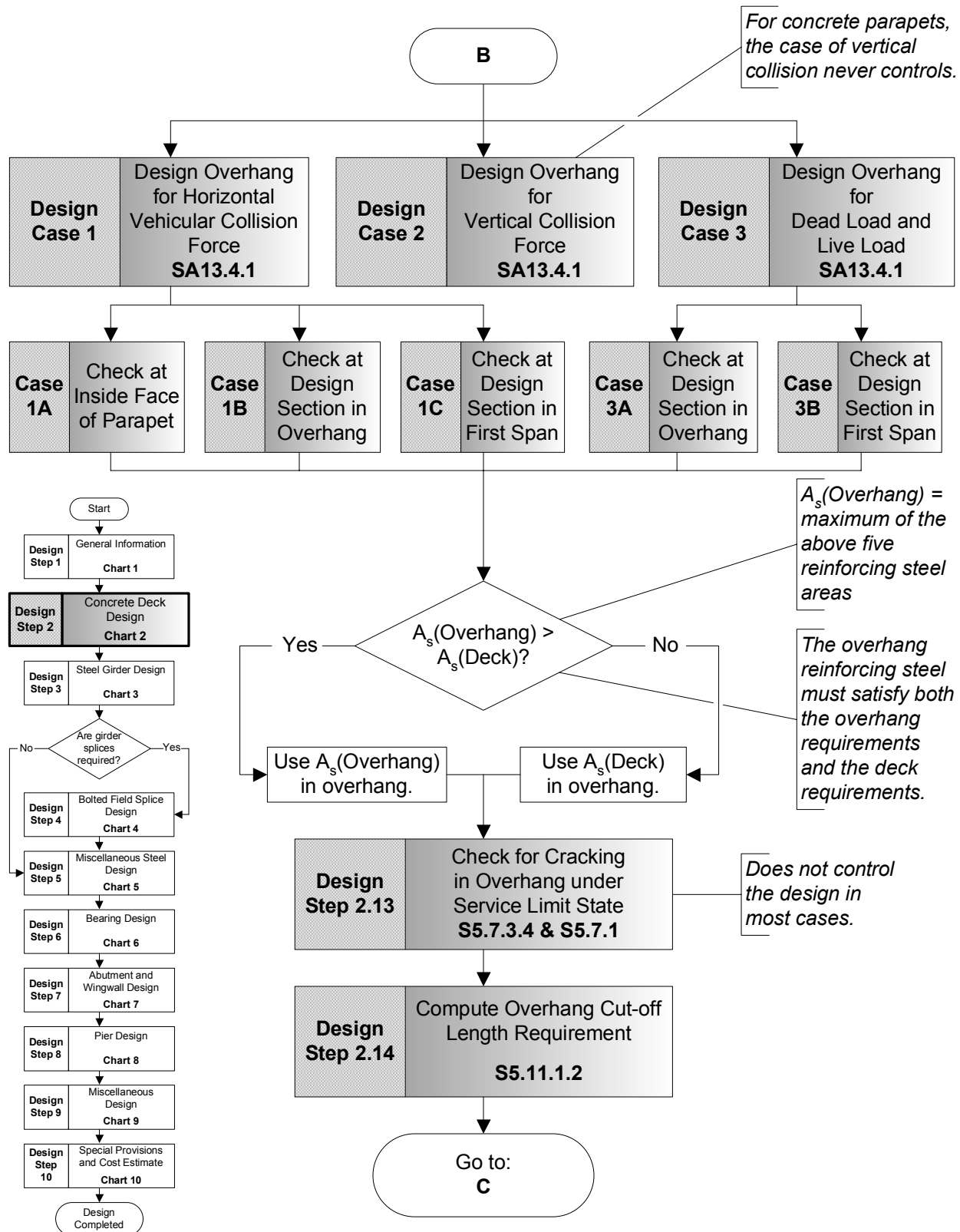

Concrete Deck Design Flowchart (Continued) Chart 2

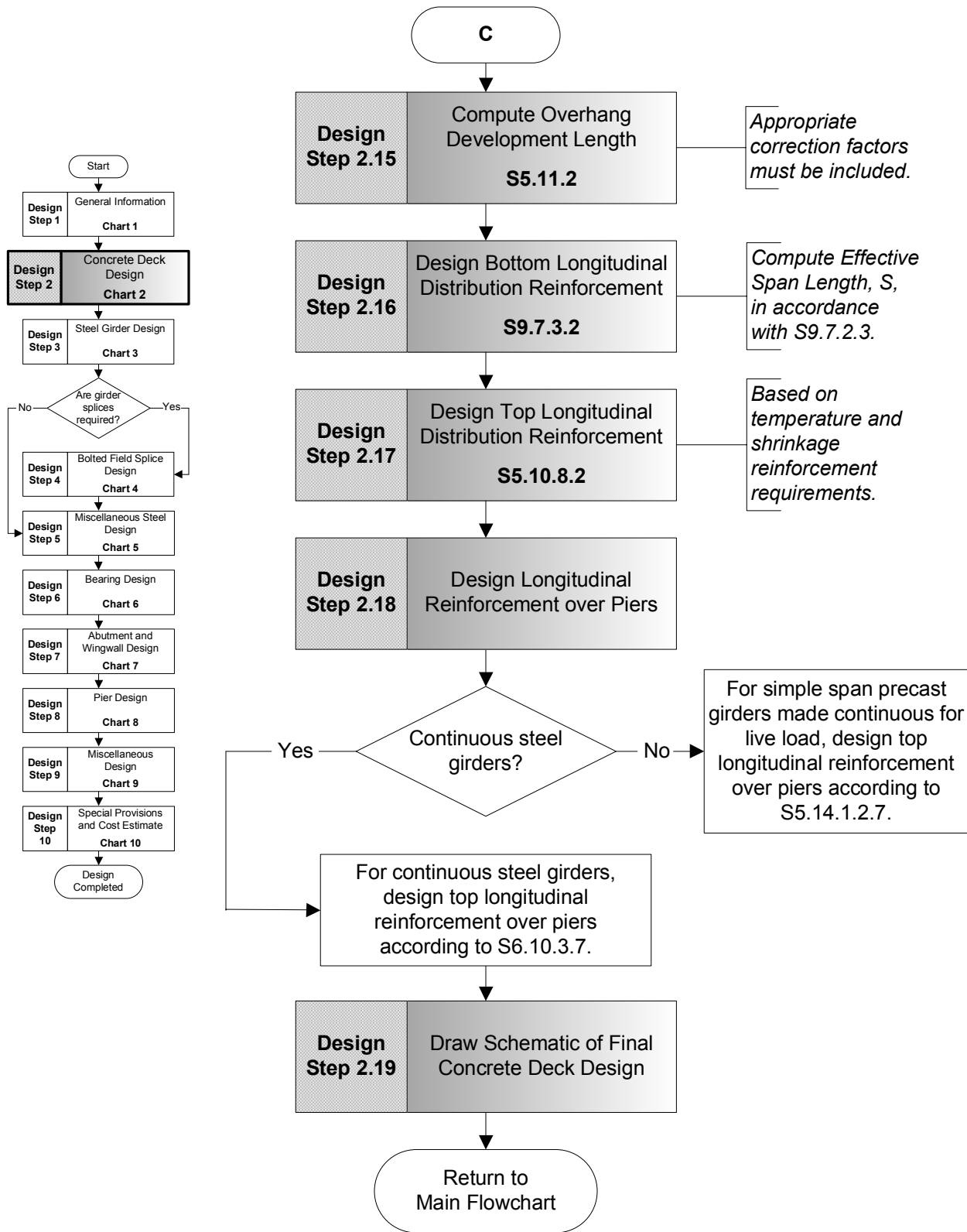

Steel Girder Design Flowchart Chart 3

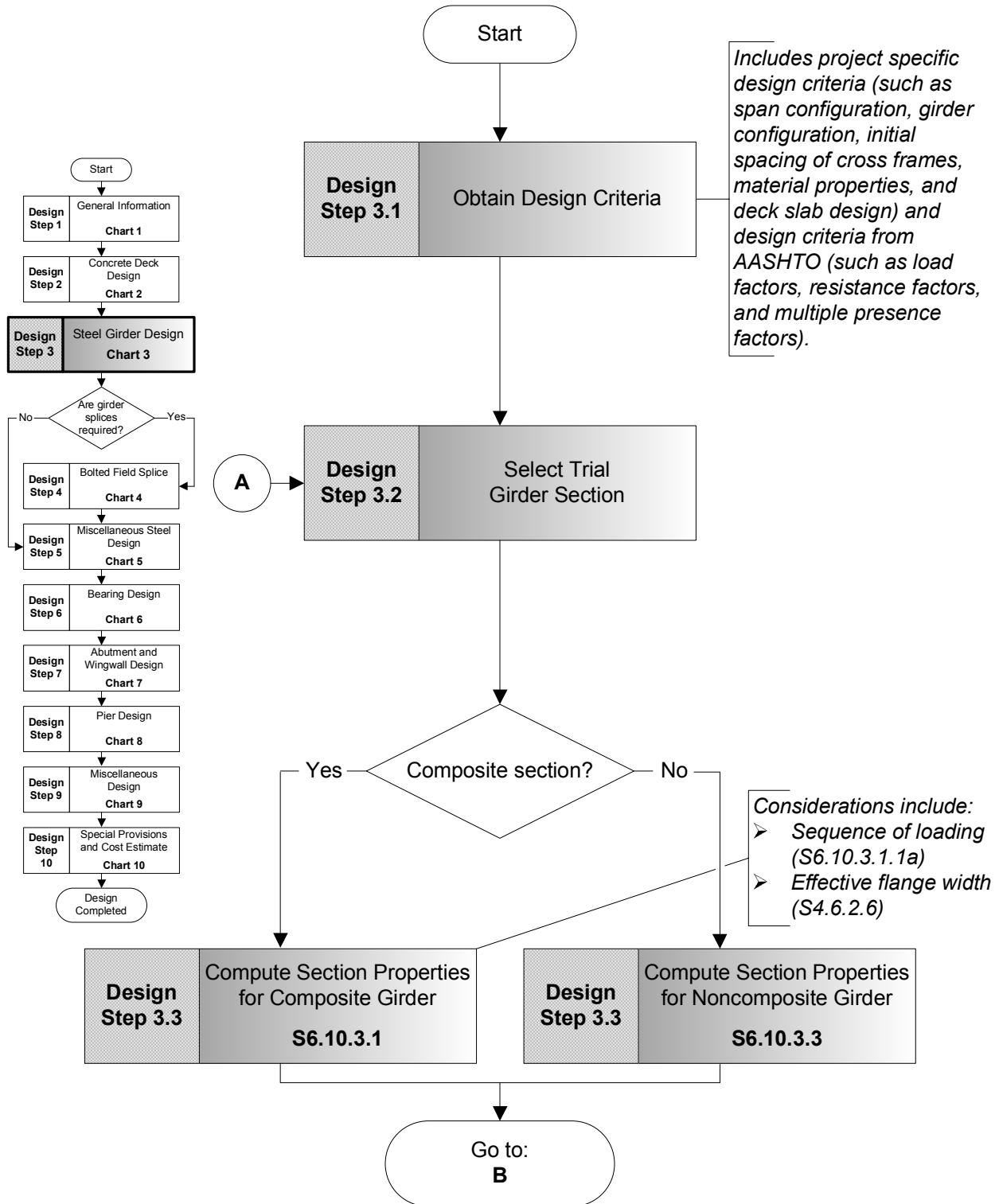

Steel Girder Design Flowchart (Continued) Chart 3

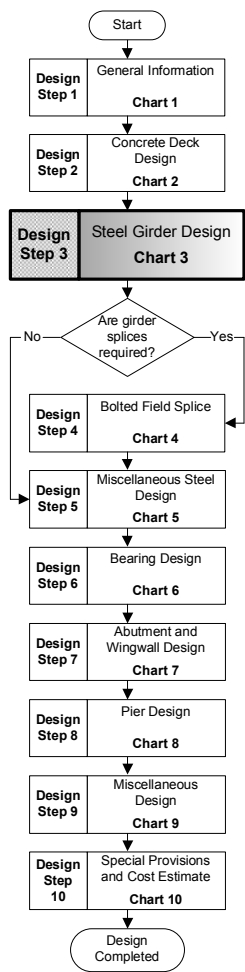
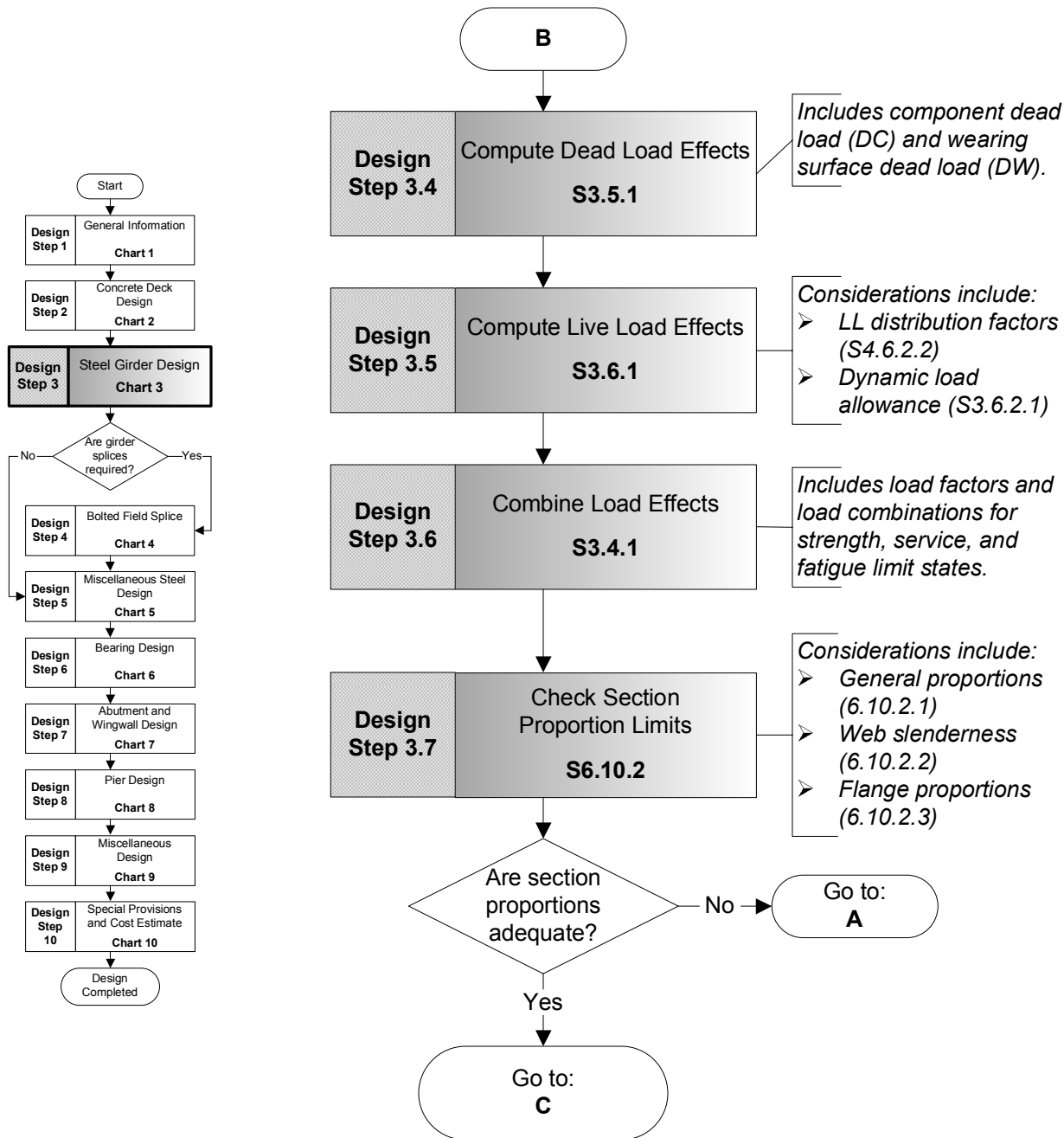

Steel Girder Design Flowchart (Continued) Chart 3

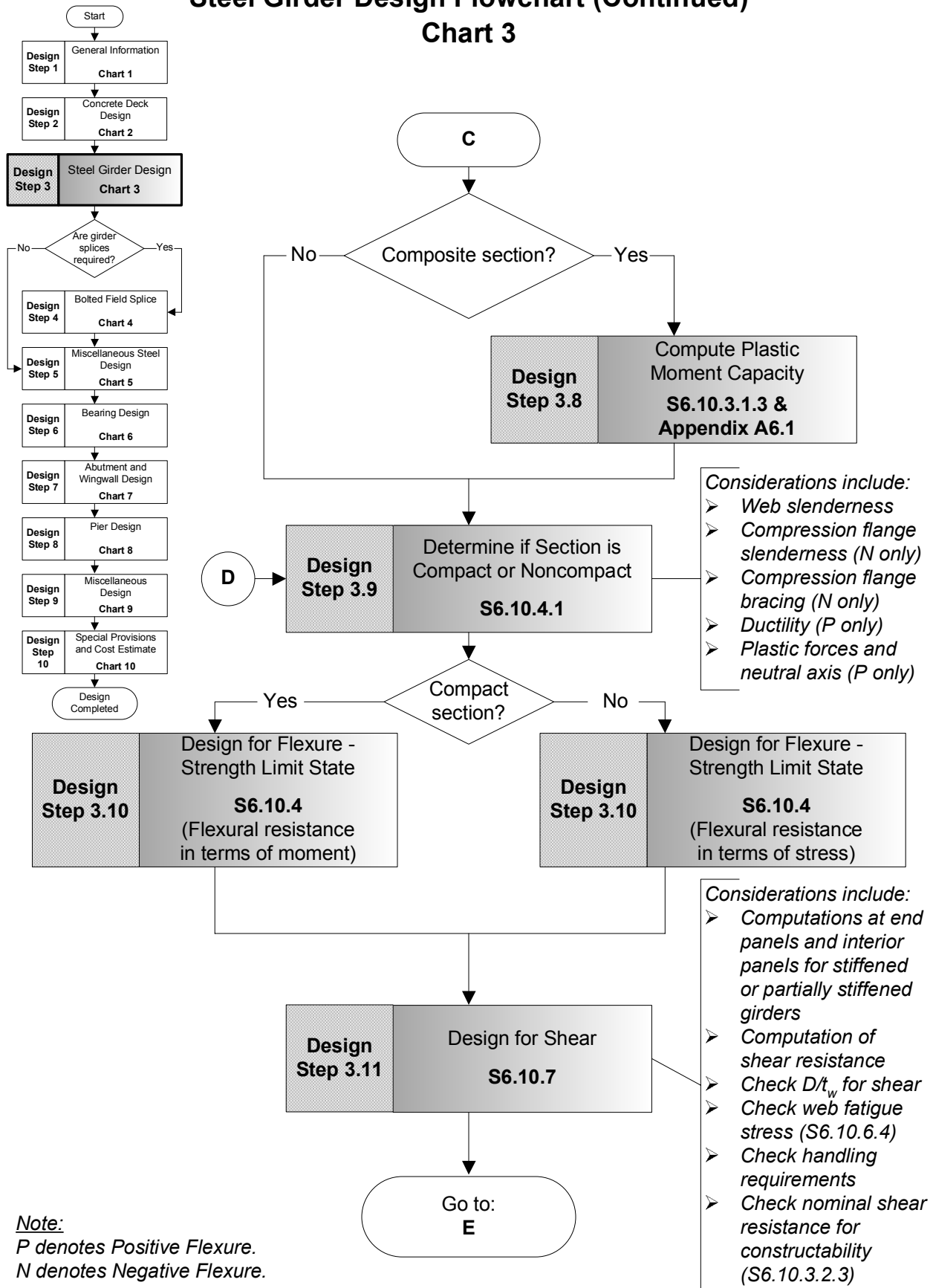

Steel Girder Design Flowchart (Continued) Chart 3

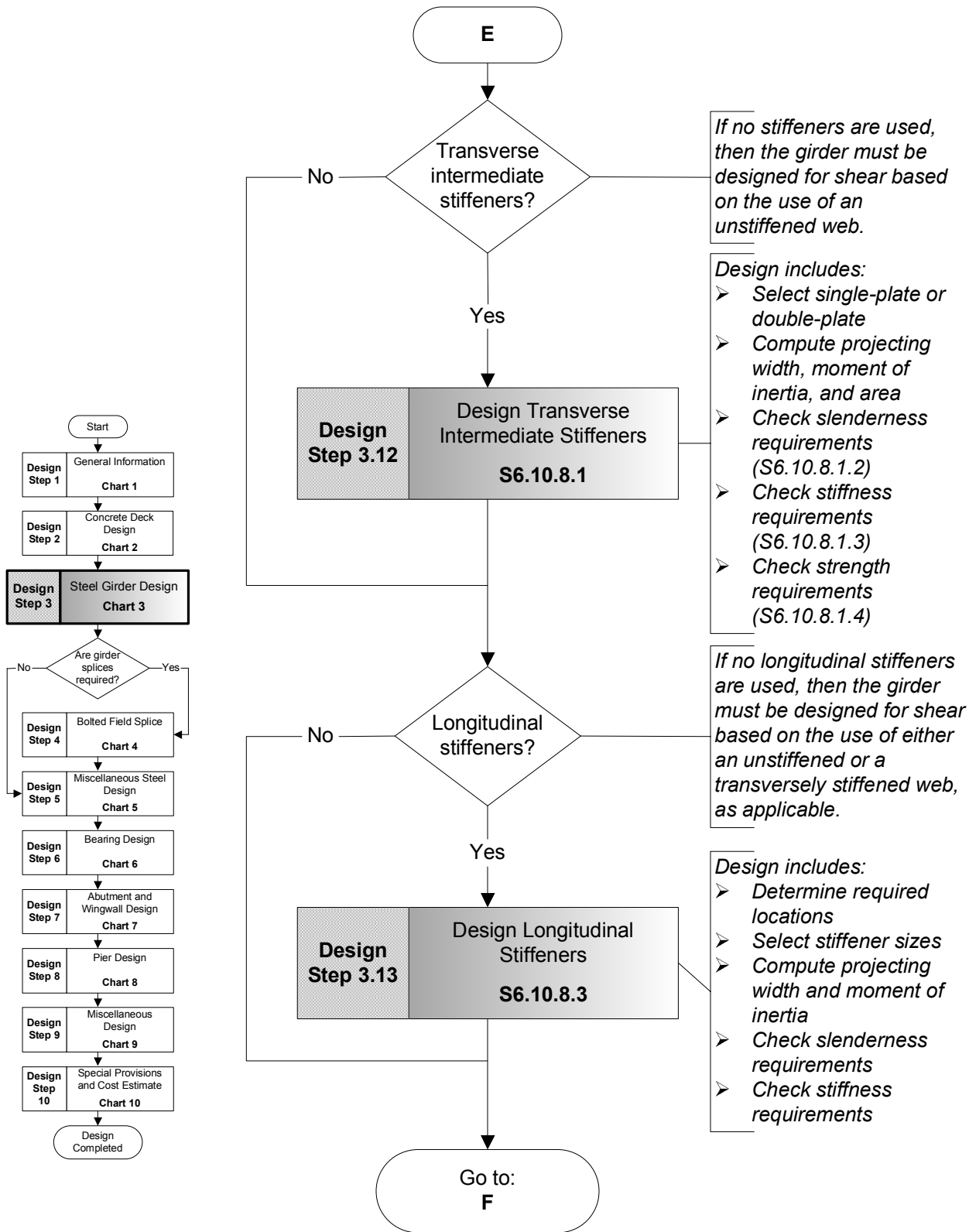

Steel Girder Design Flowchart (Continued) Chart 3

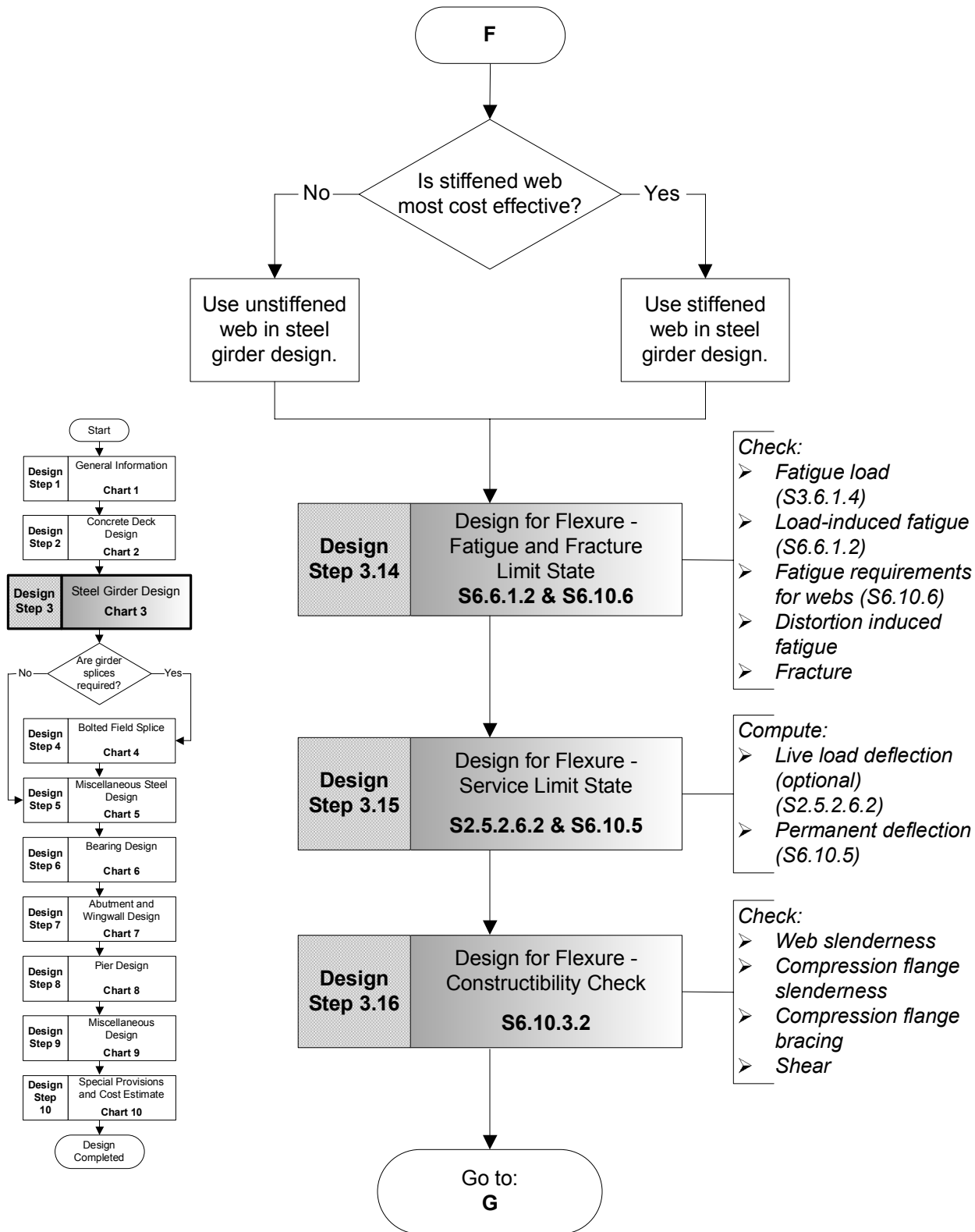

Steel Girder Design Flowchart (Continued) Chart 3

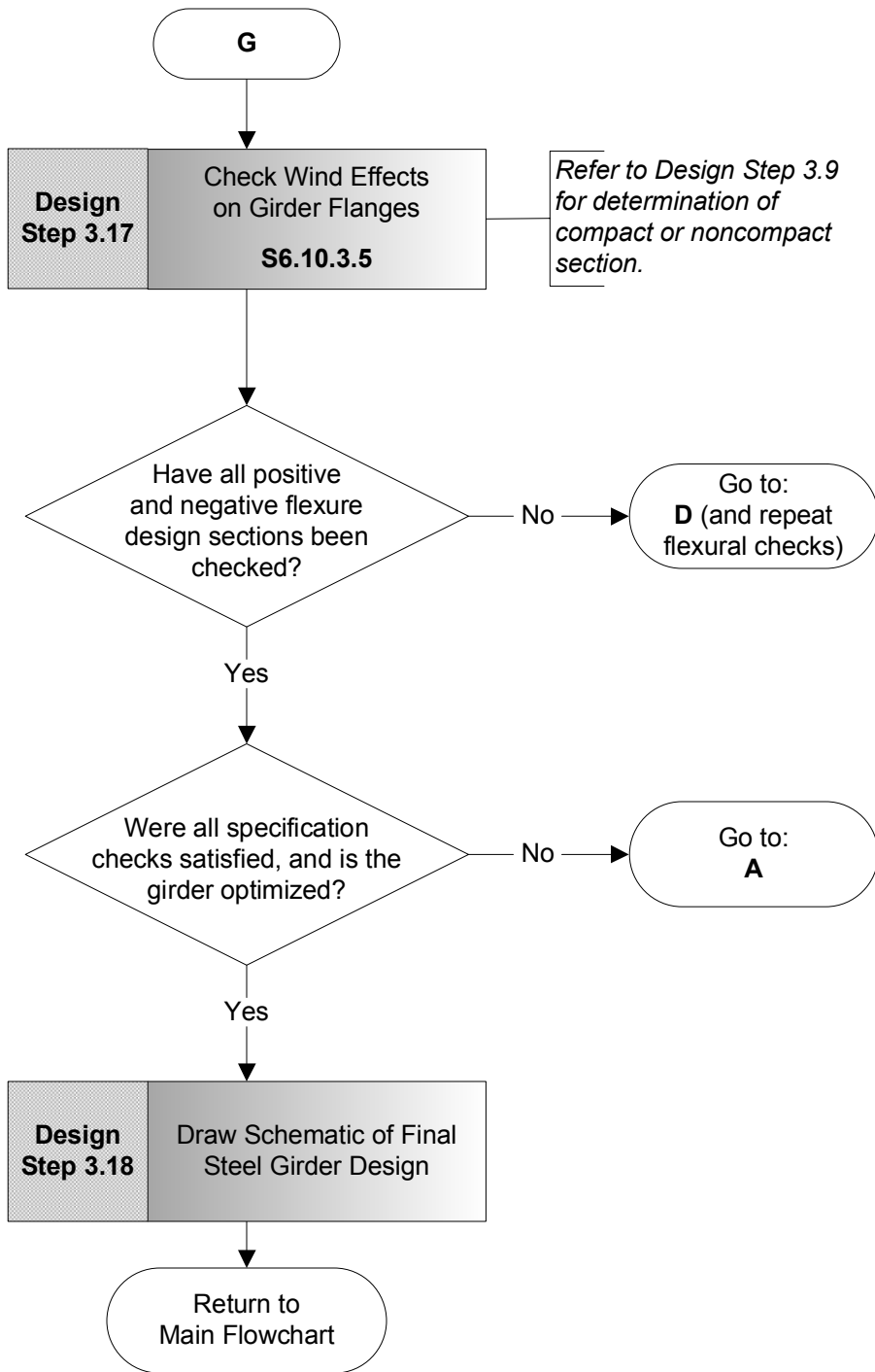
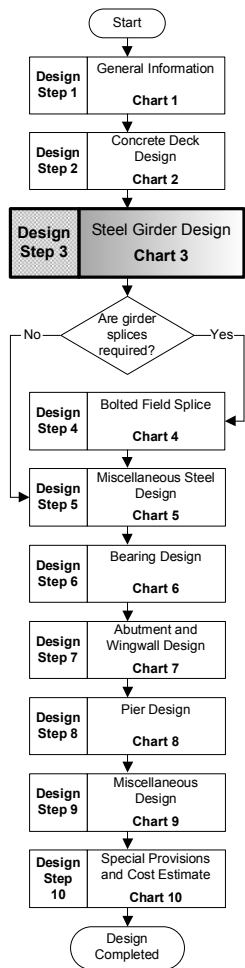

Bolted Field Splice Design Flowchart Chart 4

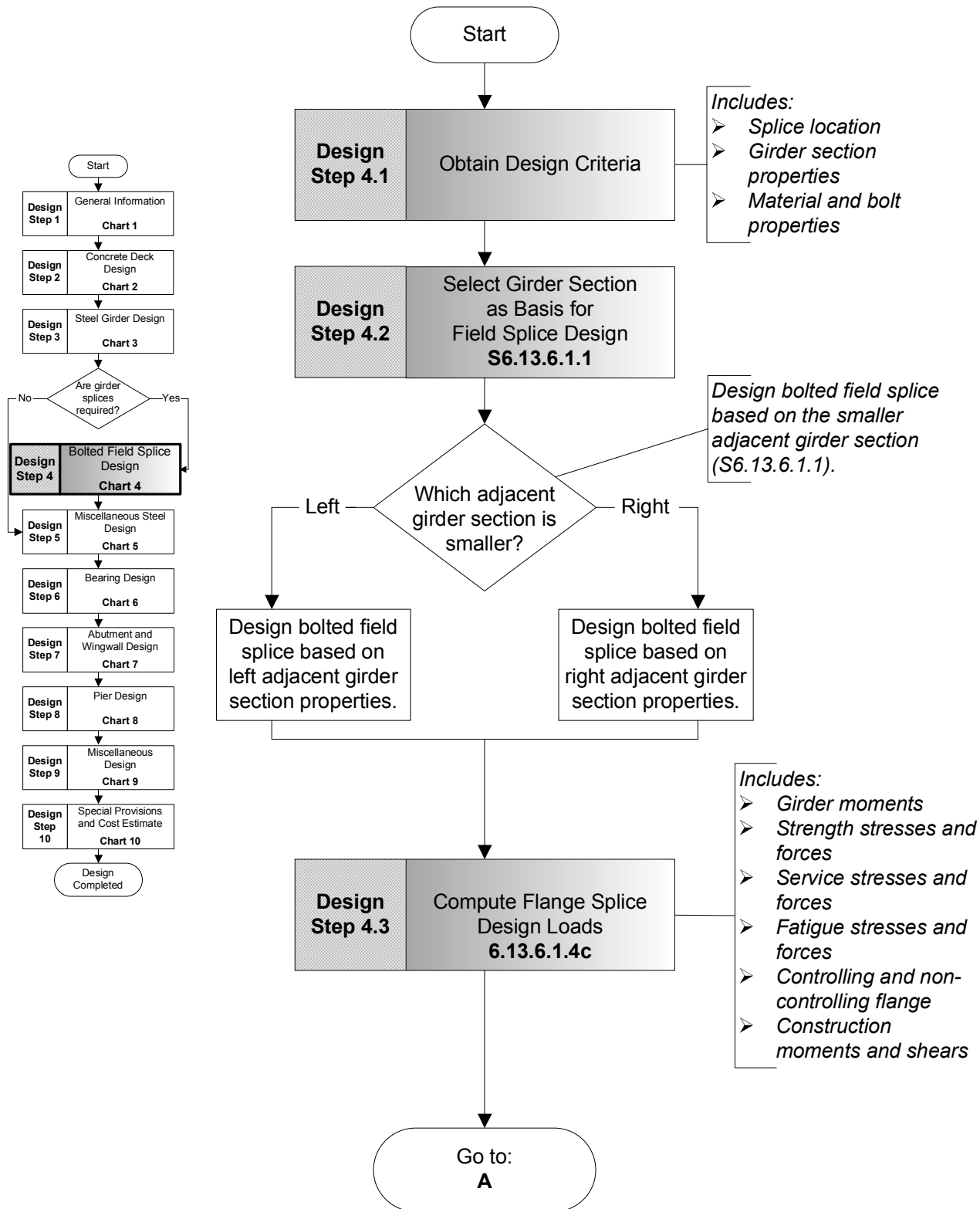

Bolted Field Splice Design Flowchart (Continued) Chart 4

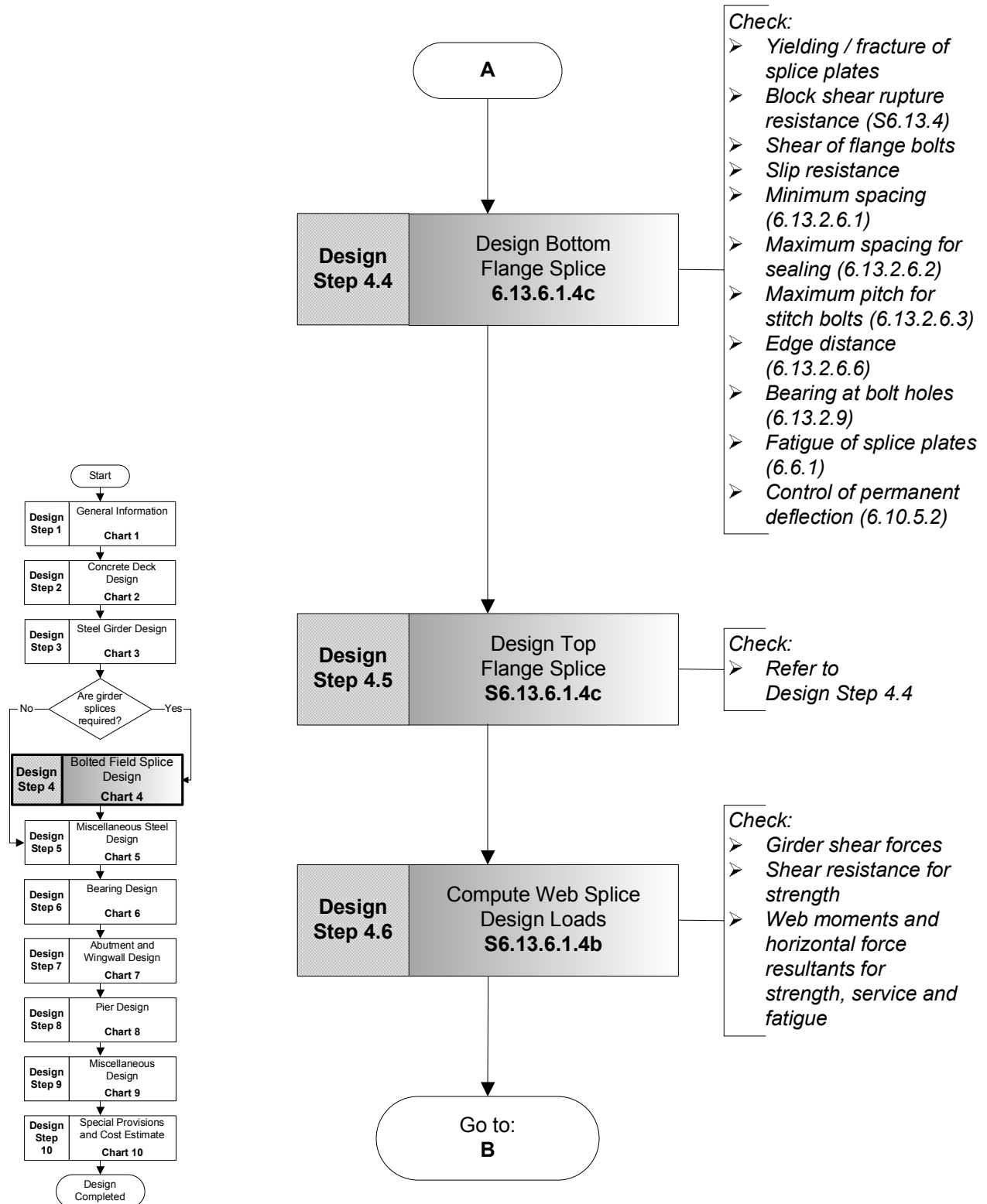

Bolted Field Splice Design Flowchart (Continued) Chart 4

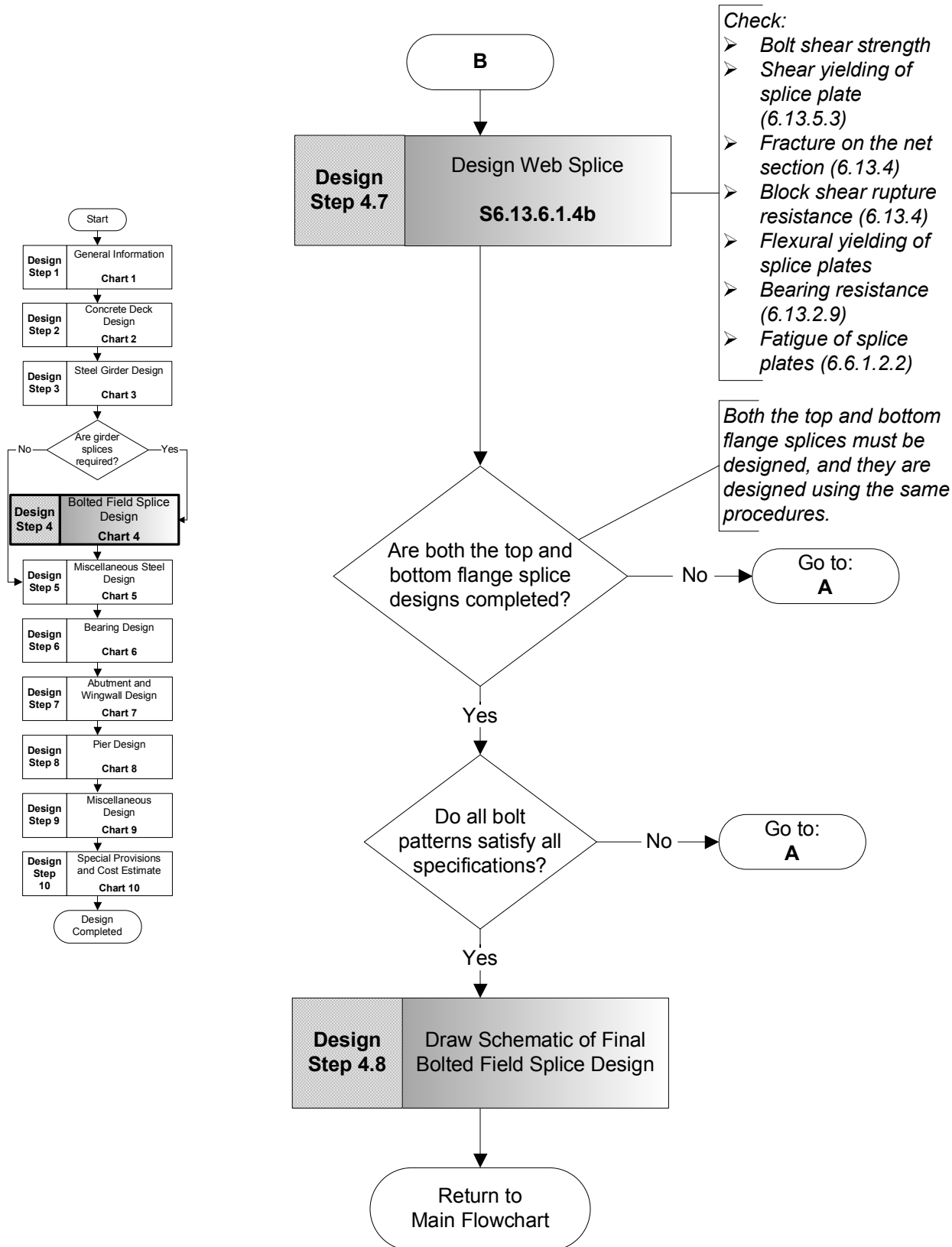

Miscellaneous Steel Design Flowchart Chart 5

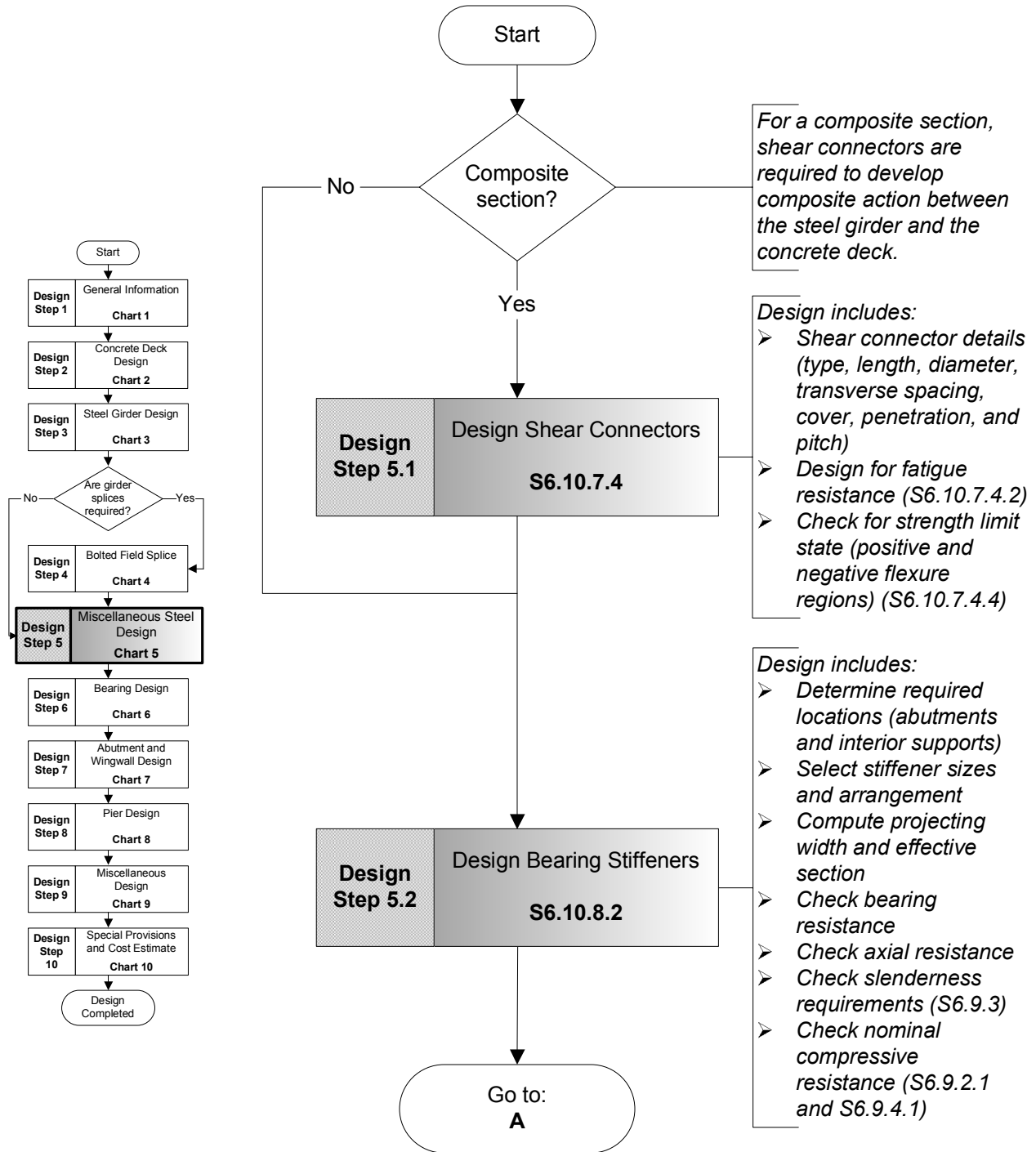

Miscellaneous Steel Design Flowchart (Continued) Chart 5

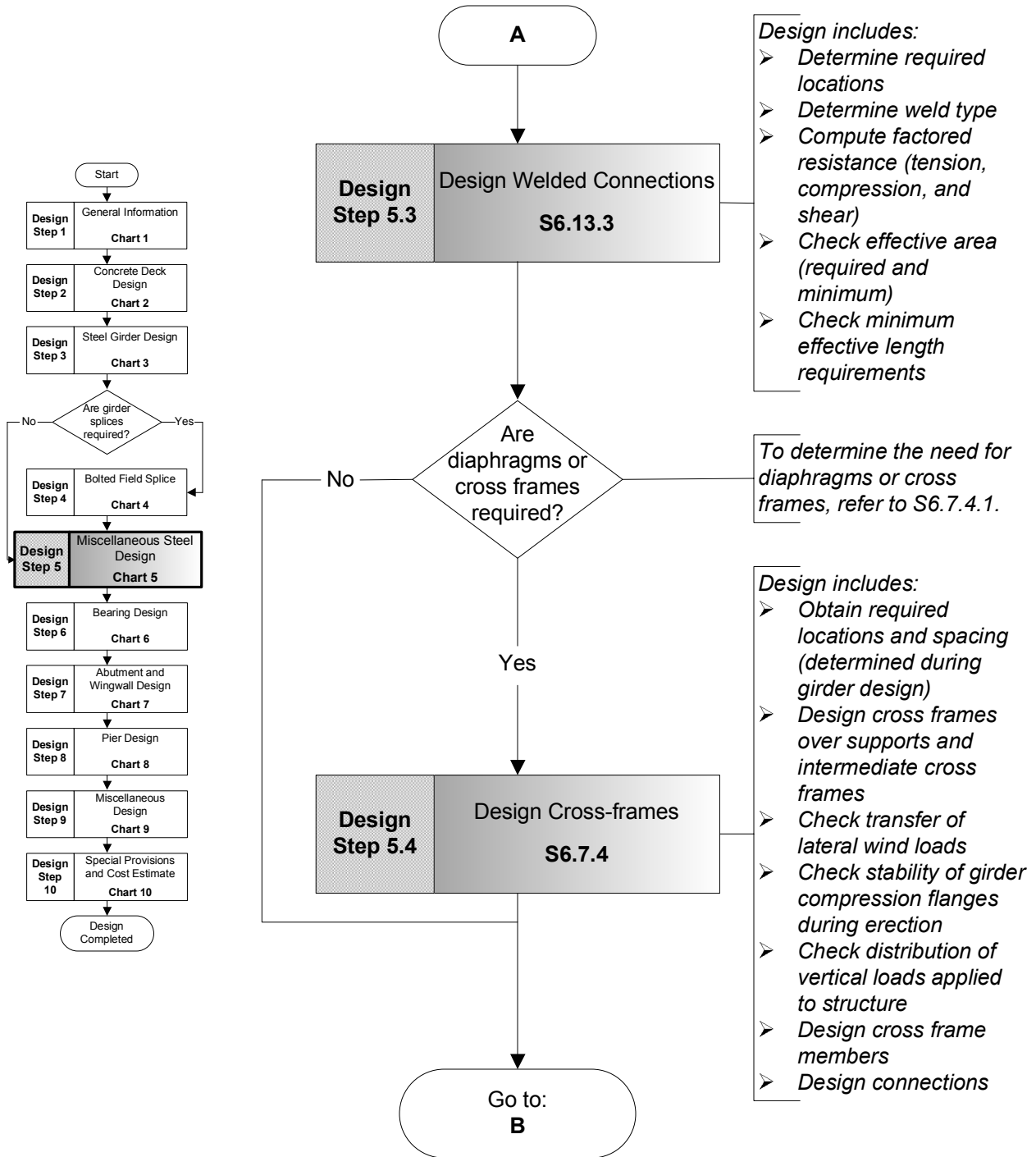

Miscellaneous Steel Design Flowchart (Continued) Chart 5

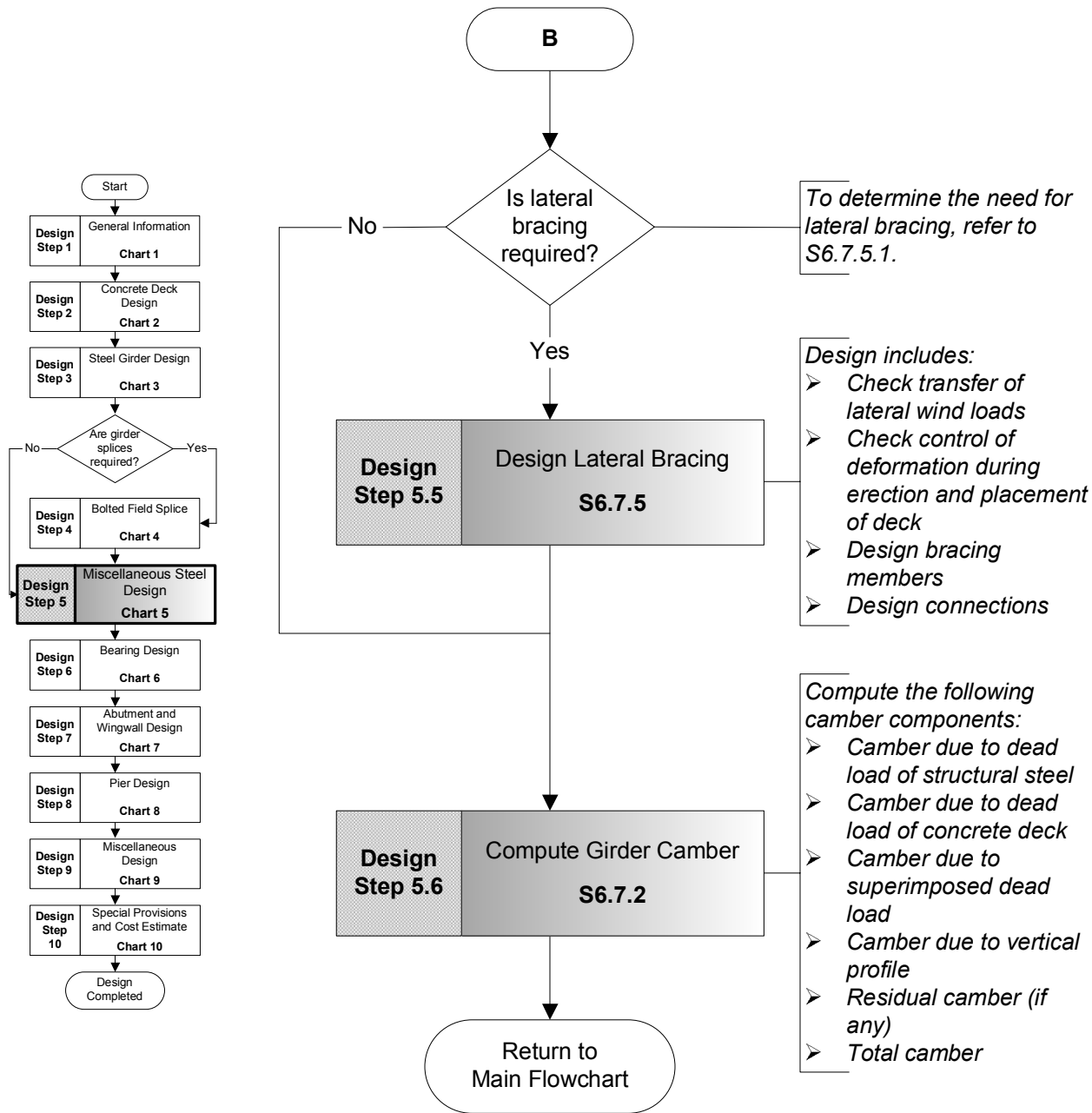

Bearing Design Flowchart Chart 6

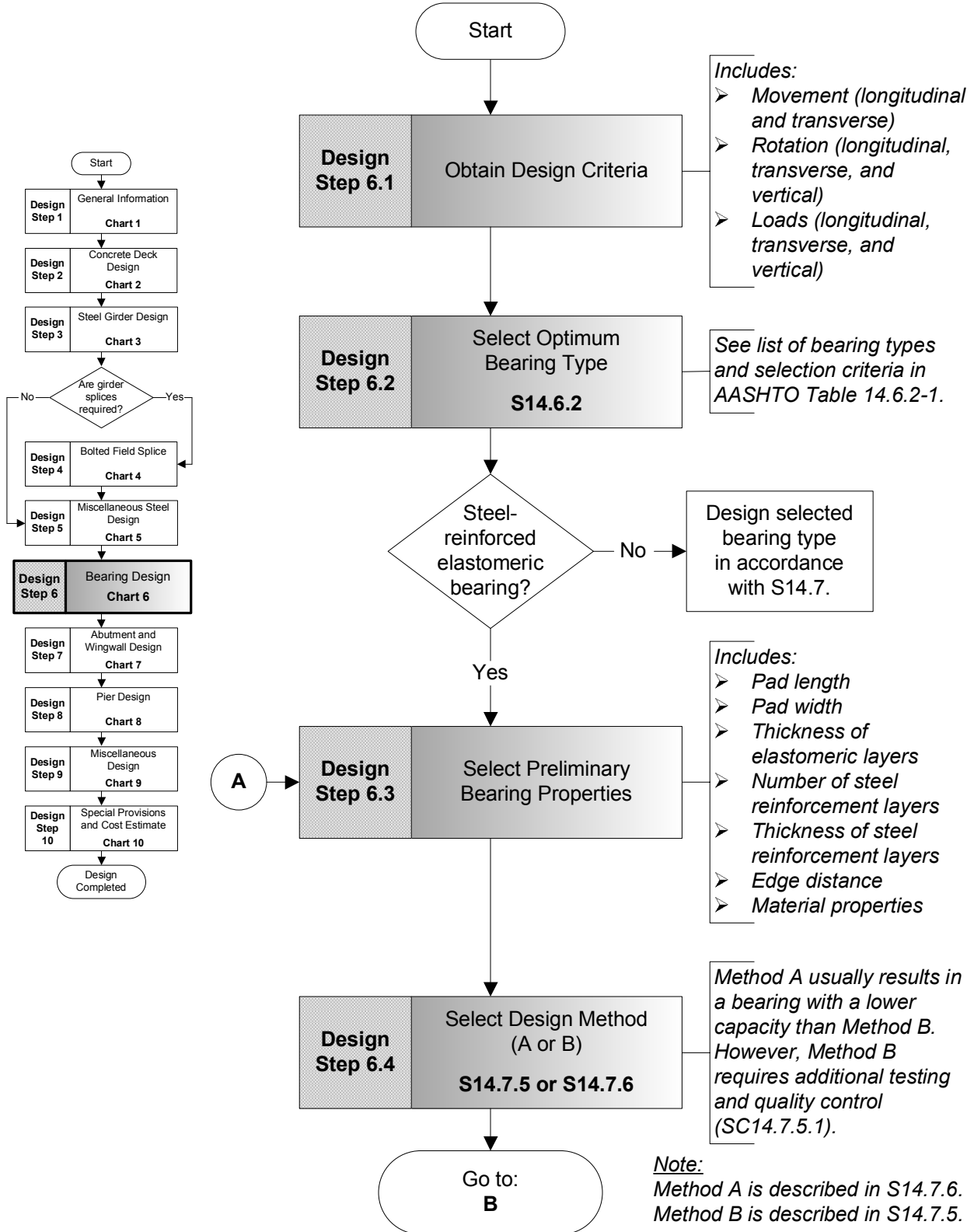

Bearing Design Flowchart (Continued) Chart 6

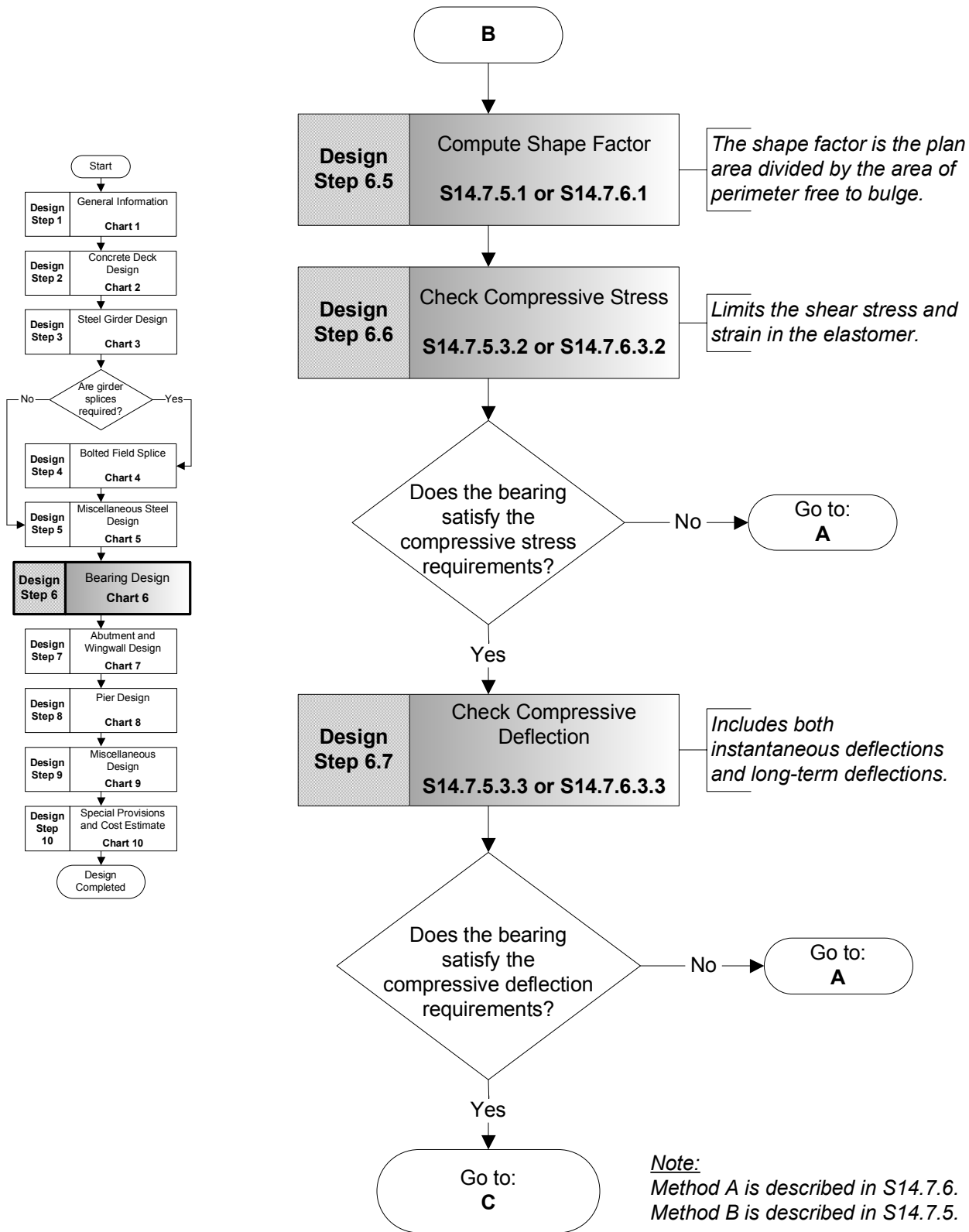

Bearing Design Flowchart (Continued) Chart 6

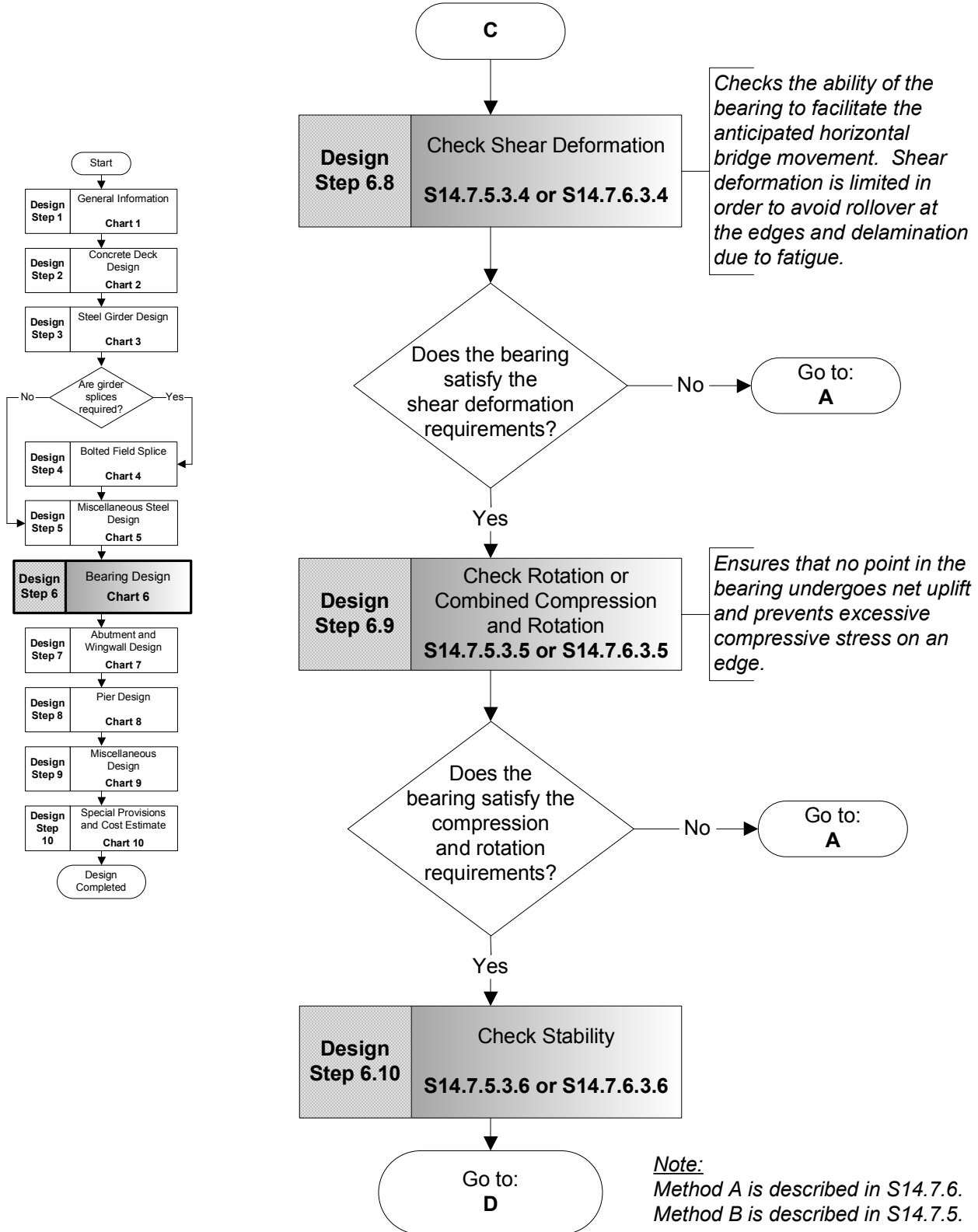

Bearing Design Flowchart (Continued) Chart 6

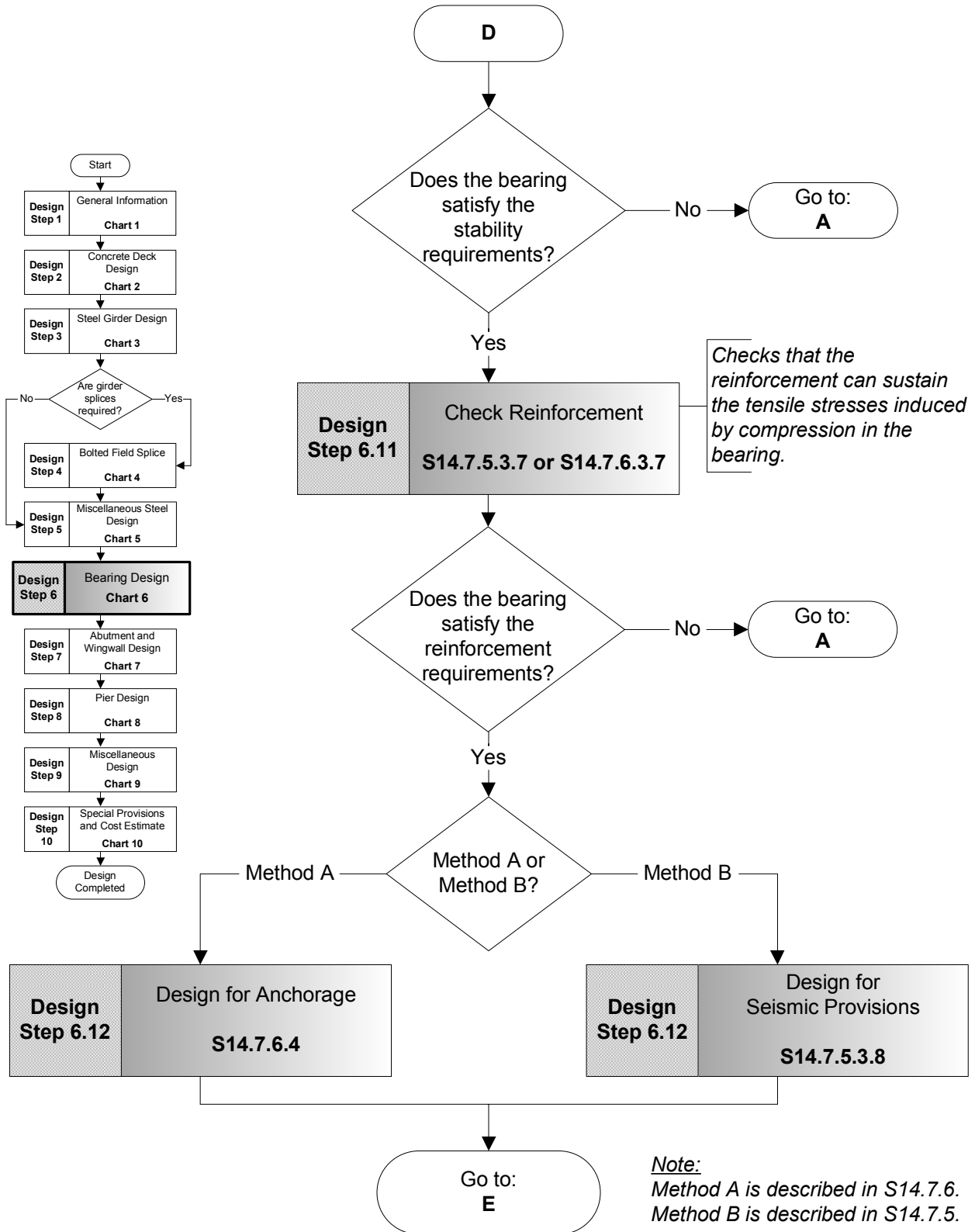

Bearing Design Flowchart (Continued) Chart 6

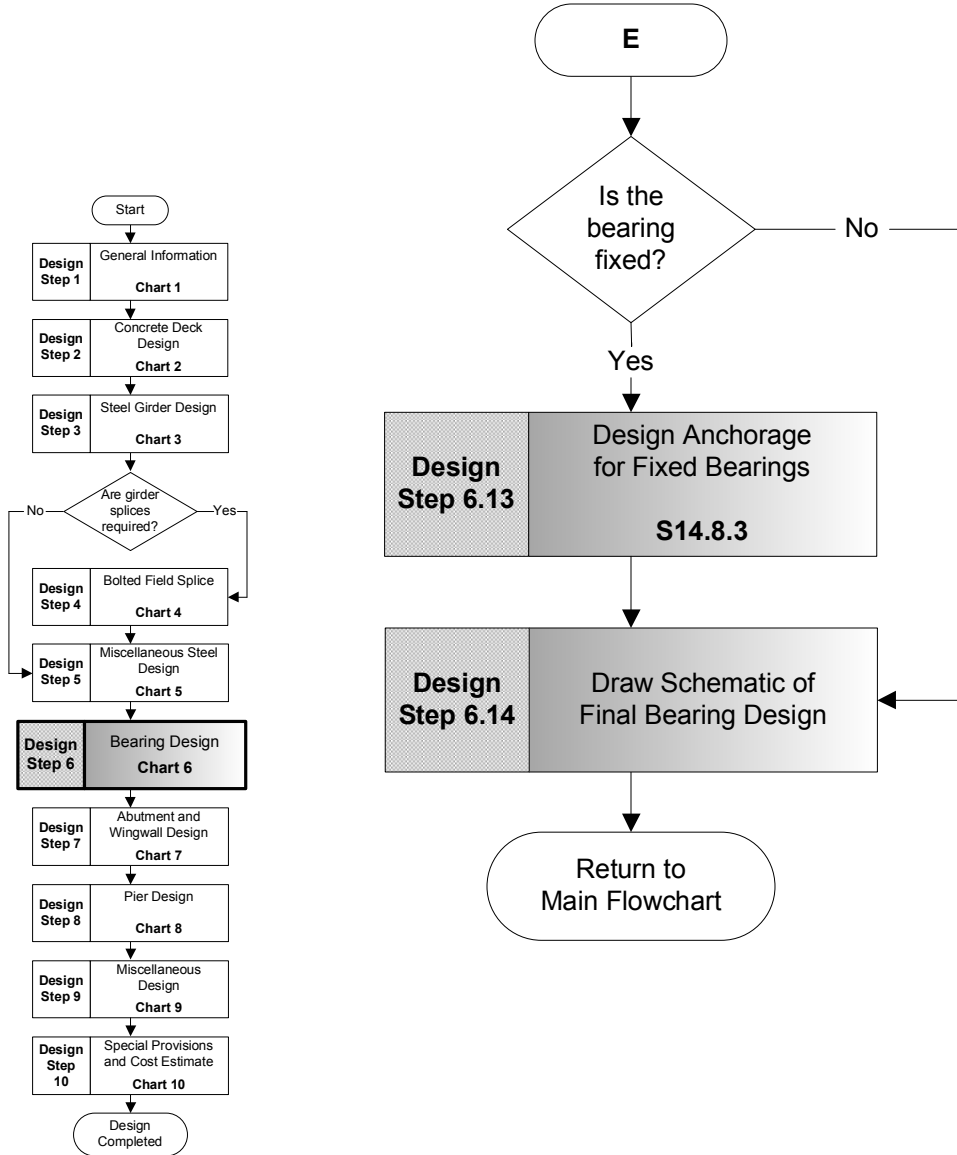

Abutment and Wingwall Design Flowchart Chart 7

Note:
Although this flowchart is written for abutment design, it also applies to wingwall design.

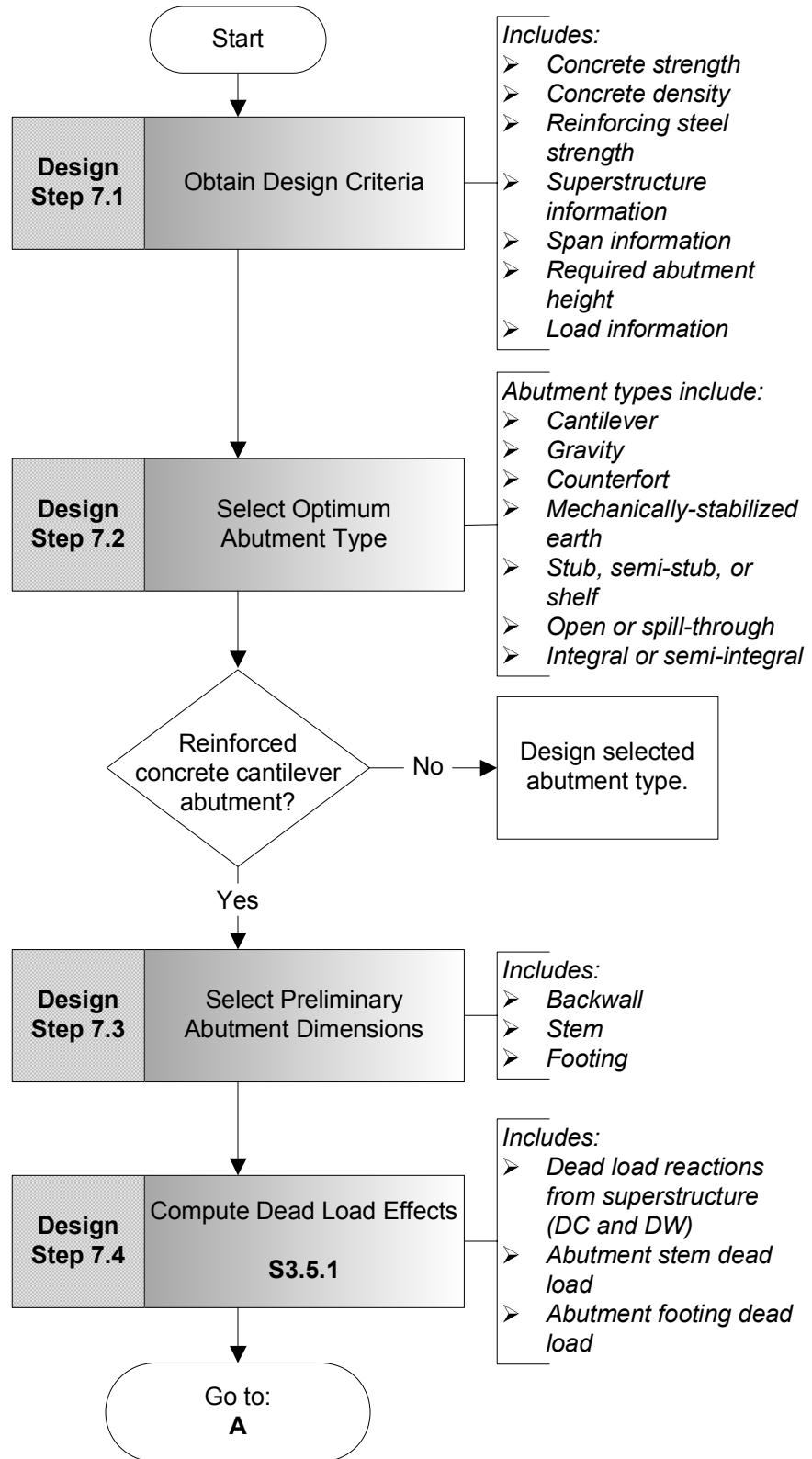
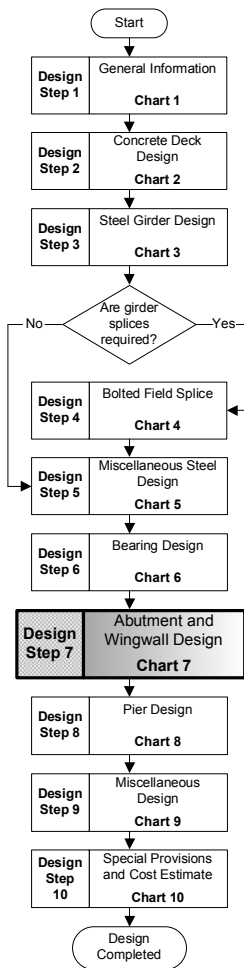

Abutment and Wingwall Design Flowchart (Continued) Chart 7

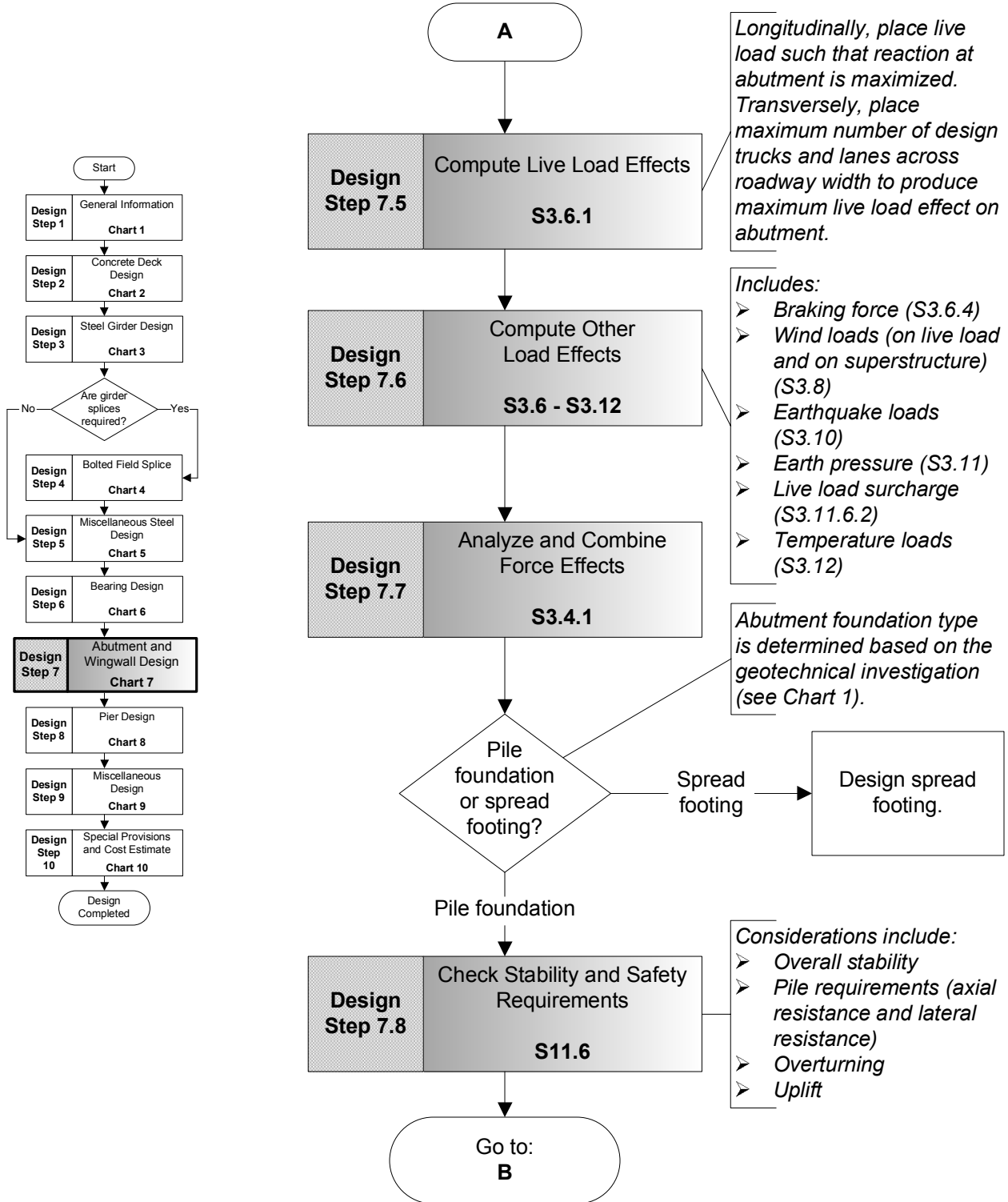

Abutment and Wingwall Design Flowchart (Continued) Chart 7

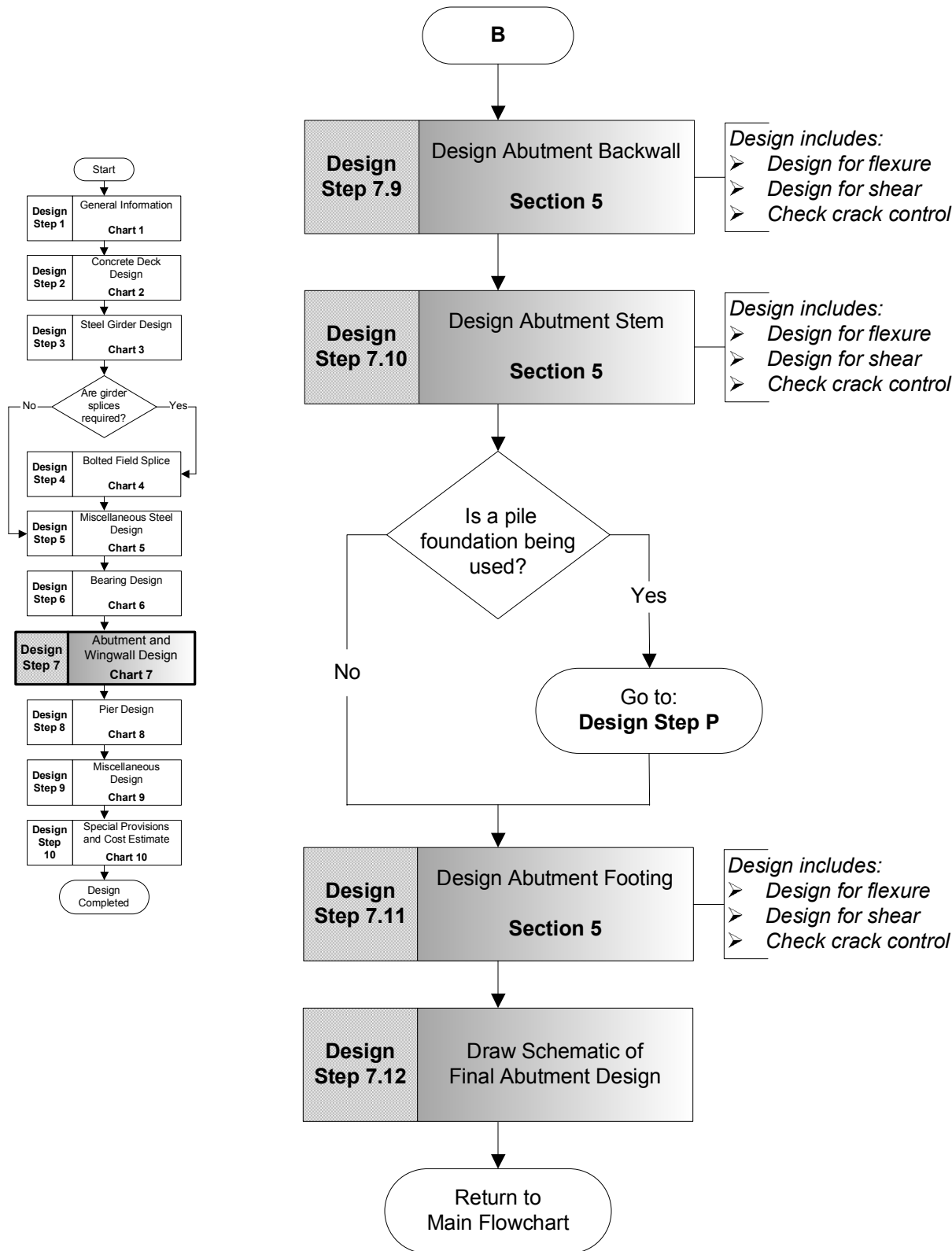

Pier Design Flowchart Chart 8

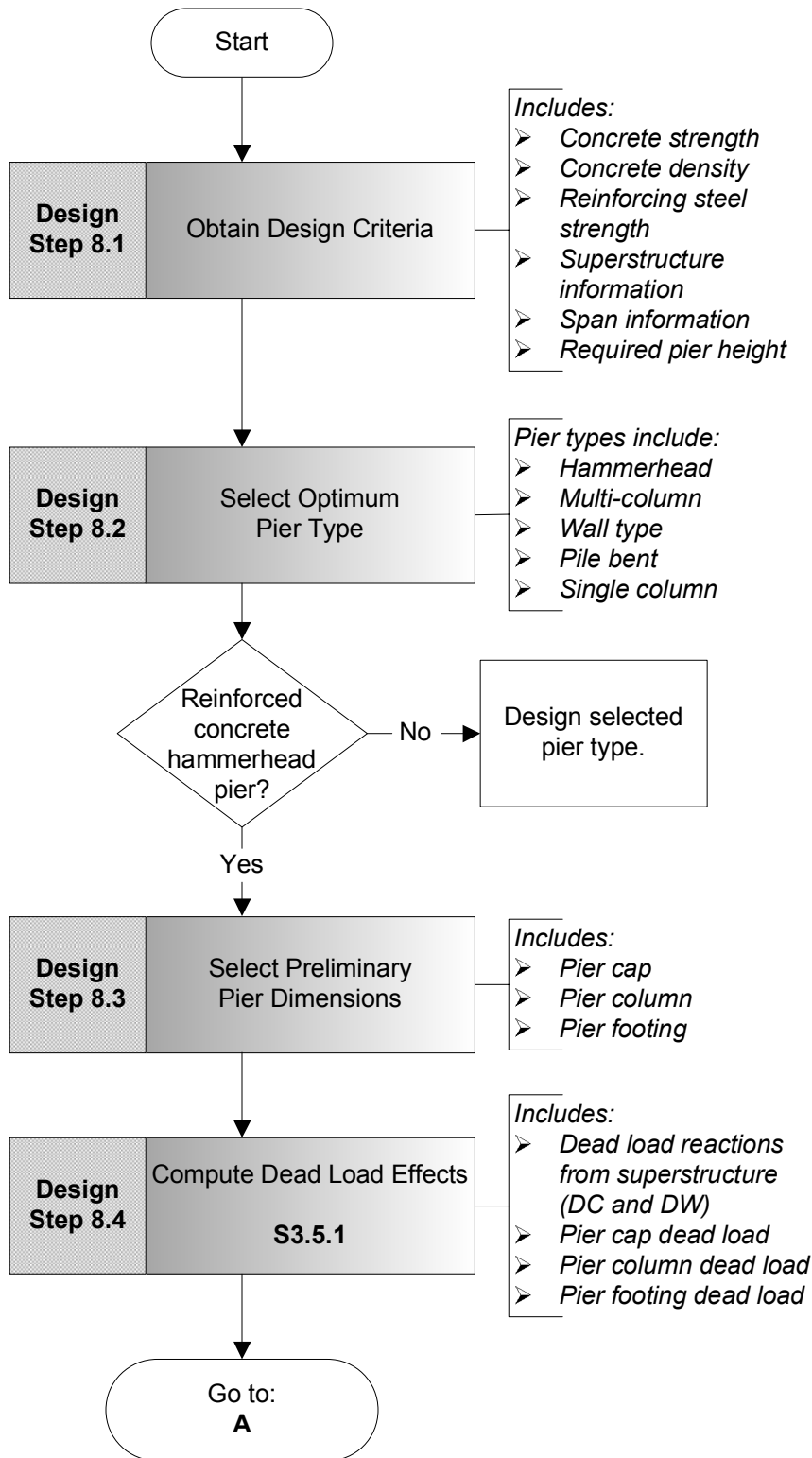
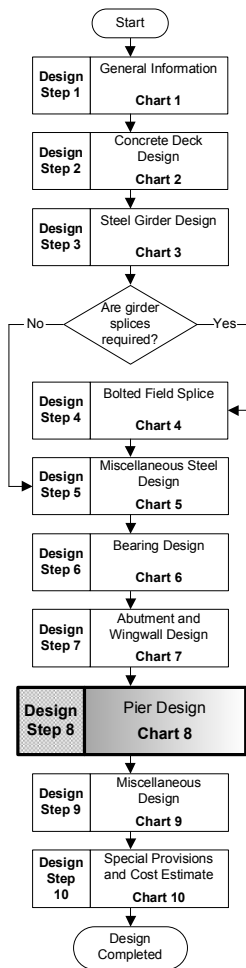

Pier Design Flowchart (Continued) Chart 8

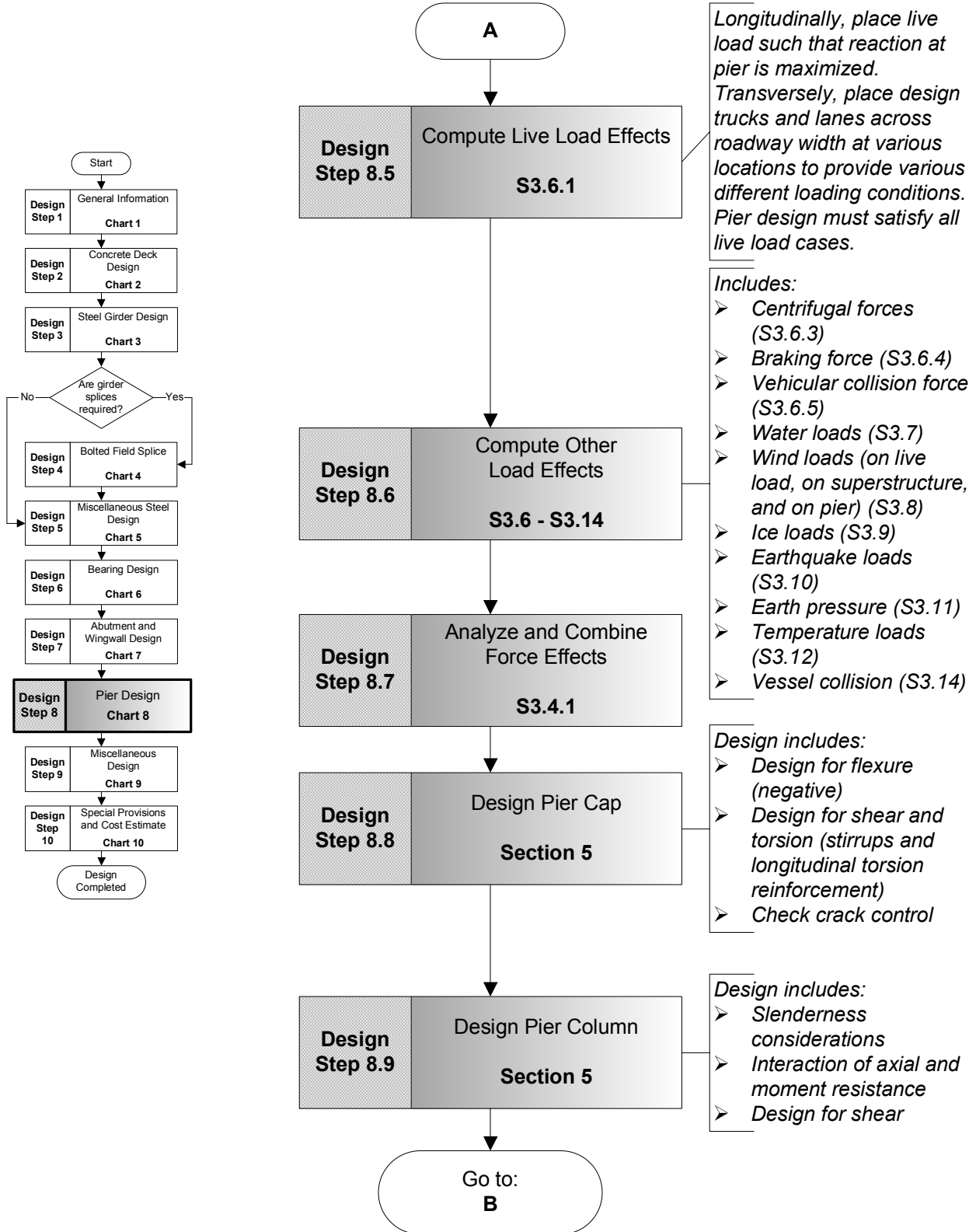

Pier Design Flowchart (Continued) Chart 8

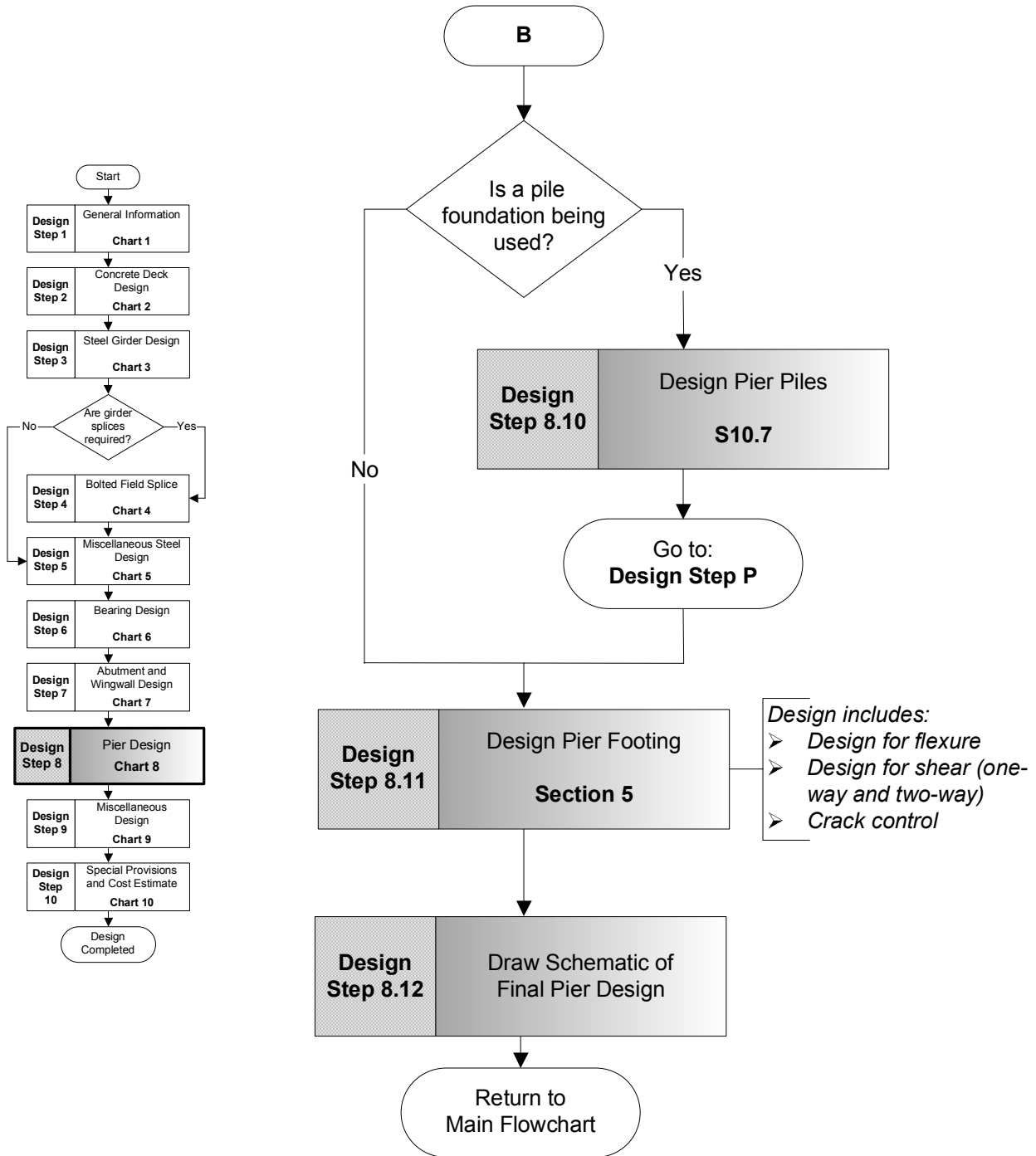

Miscellaneous Design Flowchart Chart 9

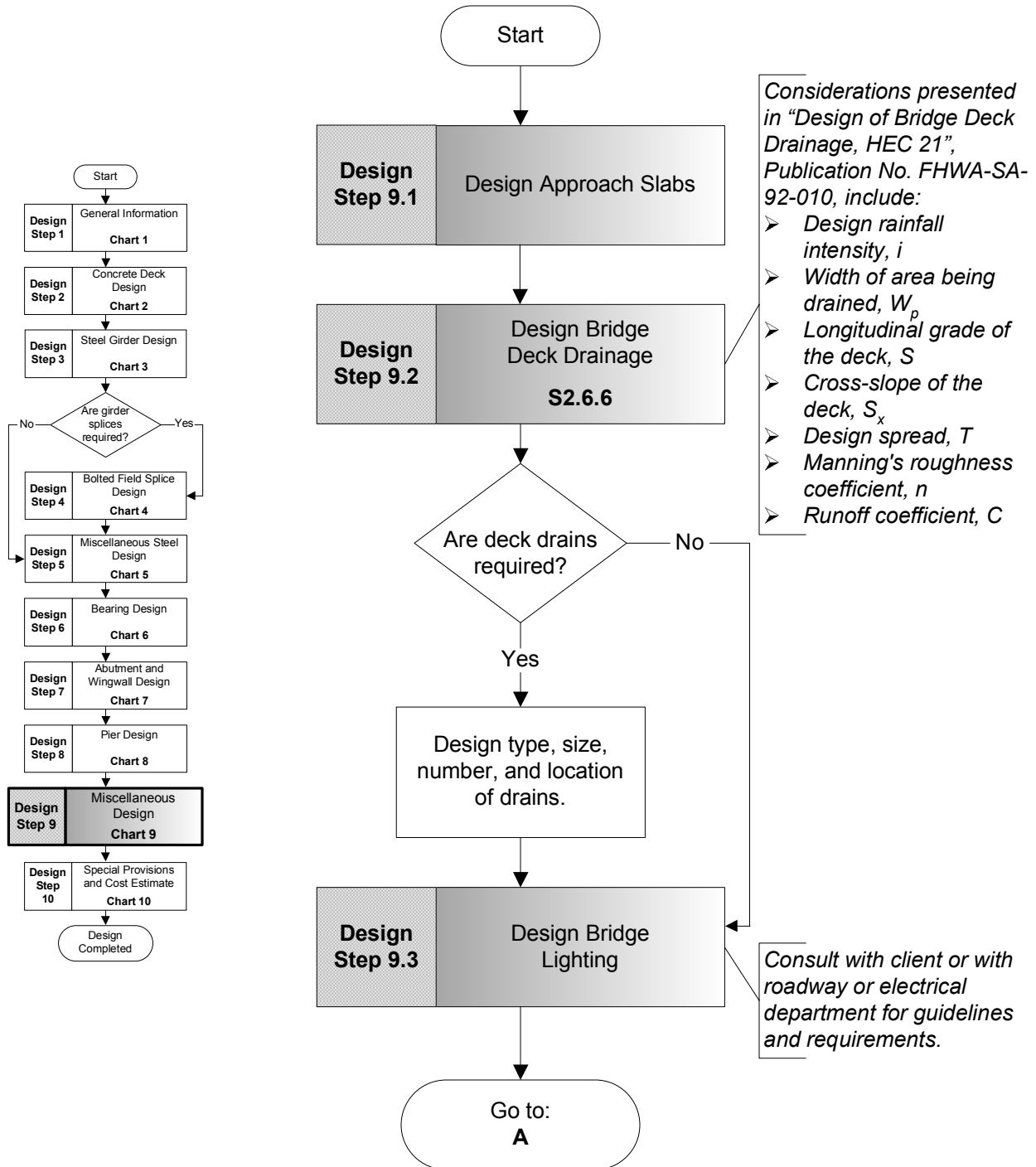

Miscellaneous Design Flowchart (Continued) Chart 9

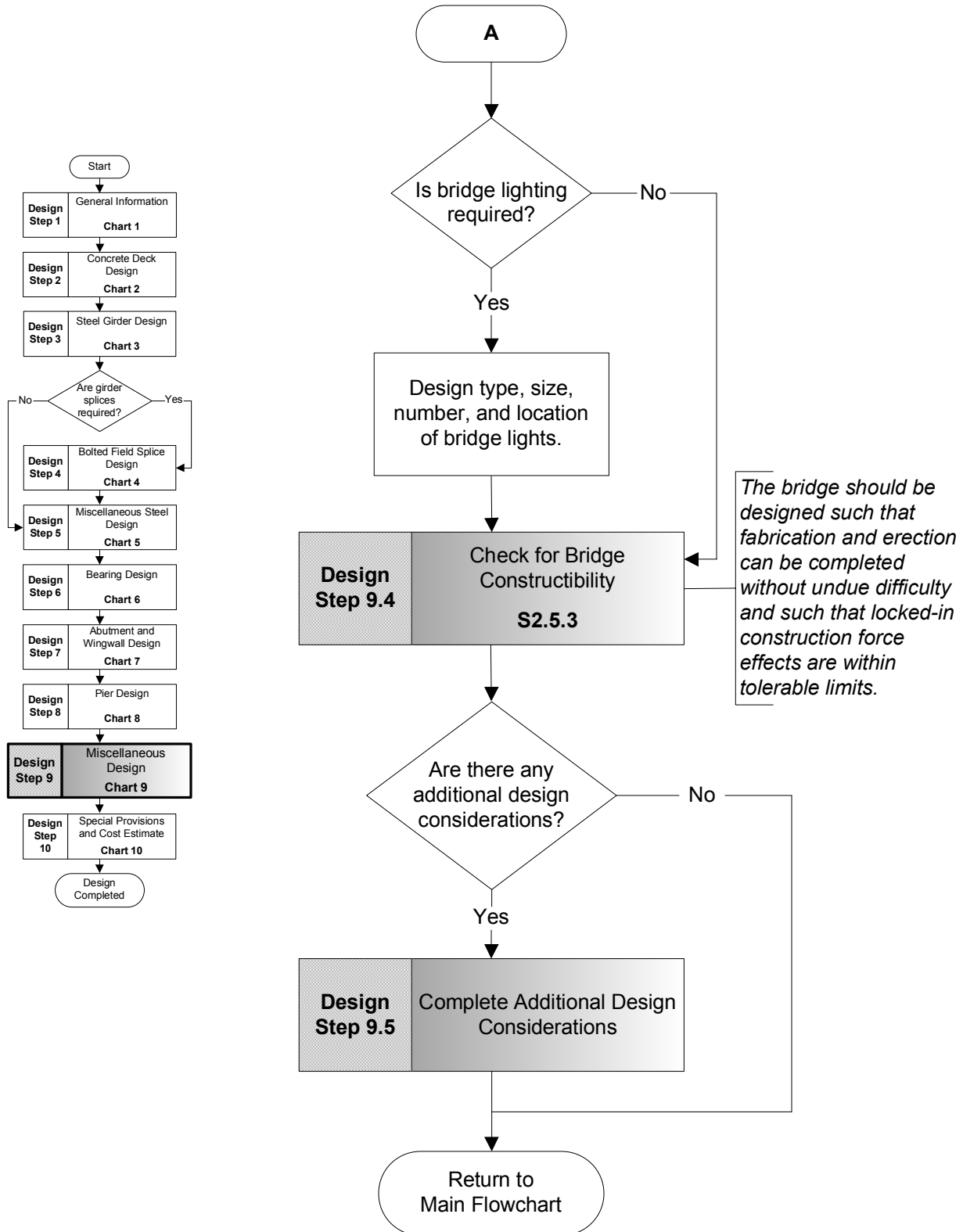

Special Provisions and Cost Estimate Flowchart Chart 10

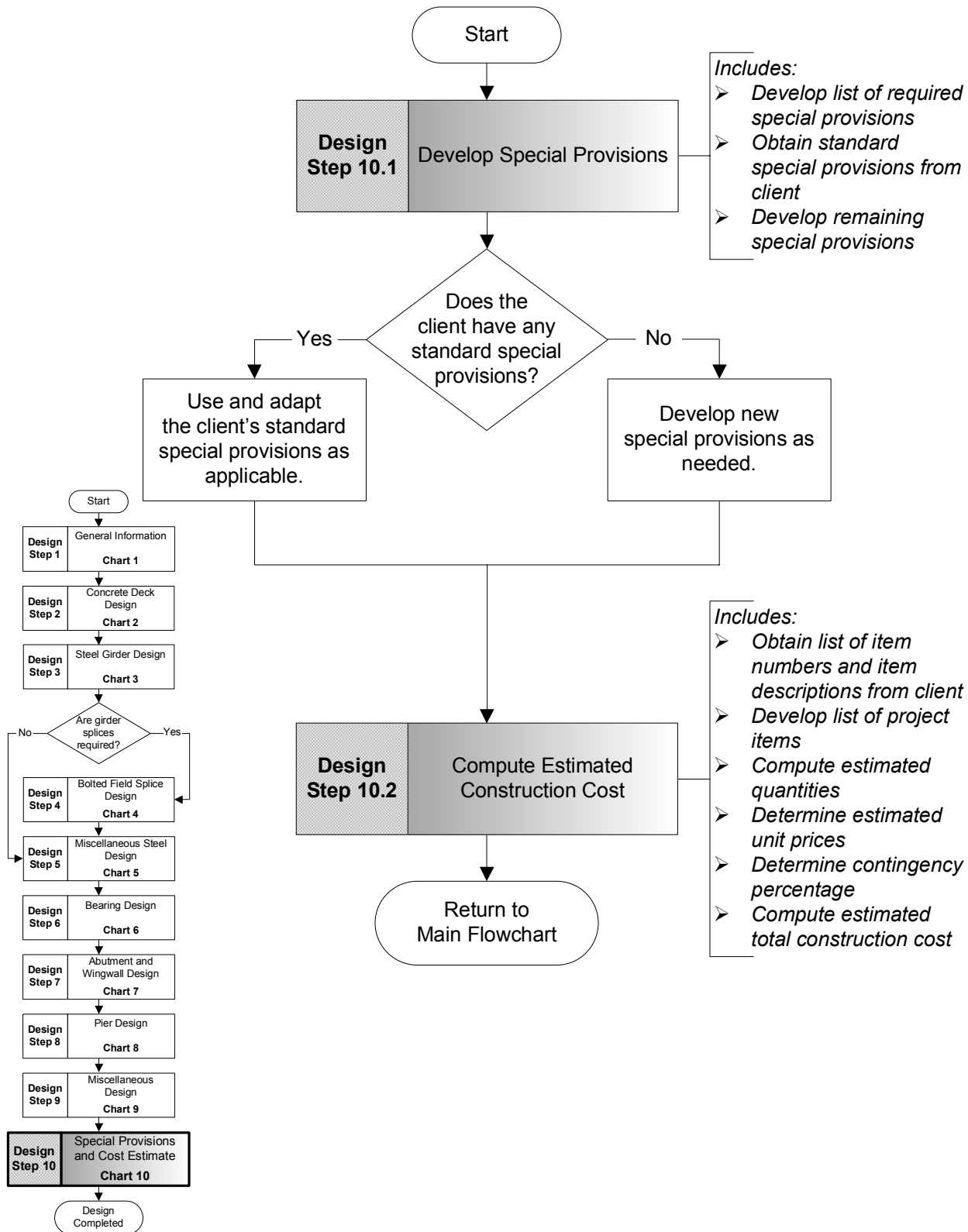

Pile Foundation Design Flowchart Chart P

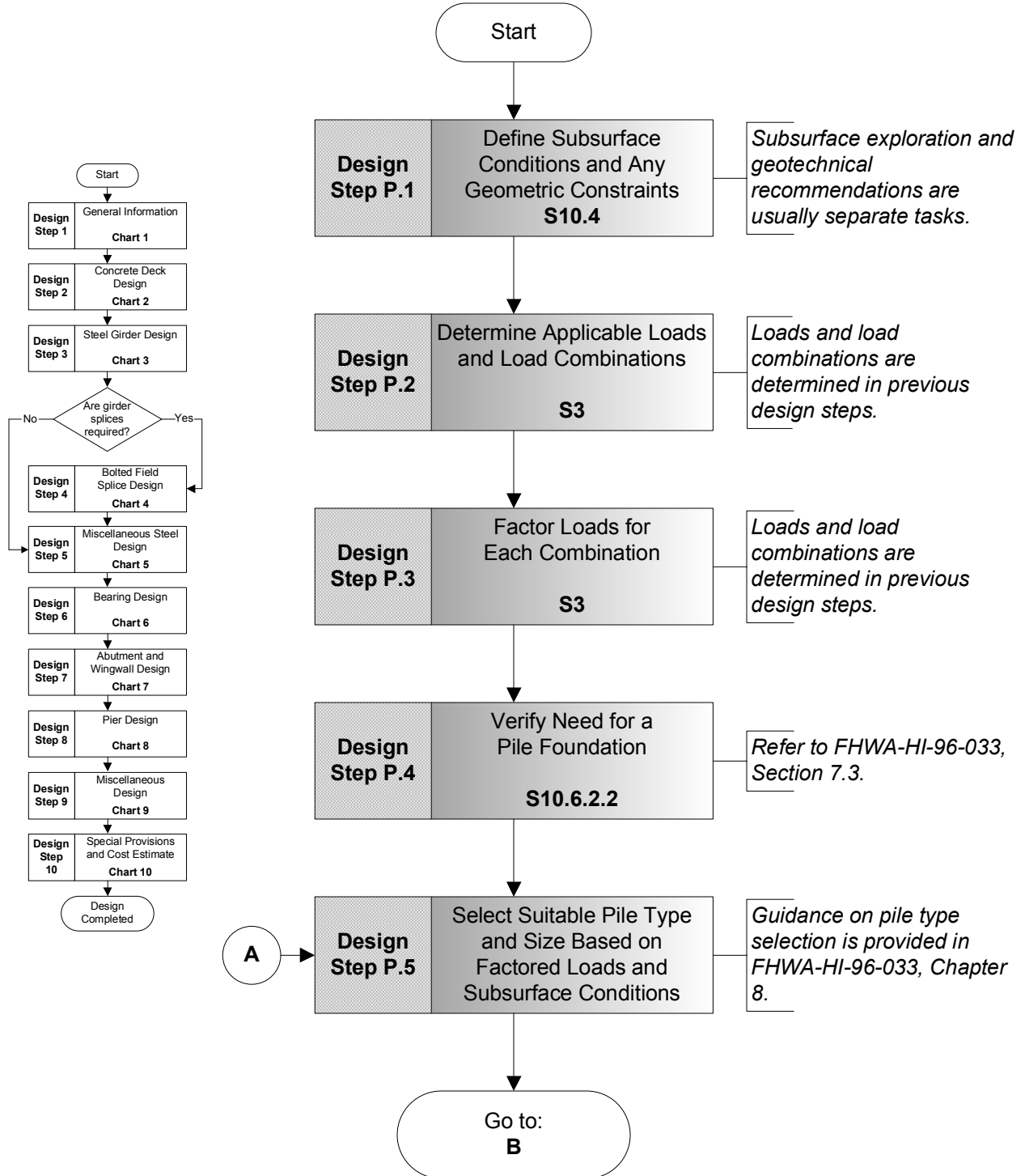

Pile Foundation Design Flowchart (Continued) Chart P

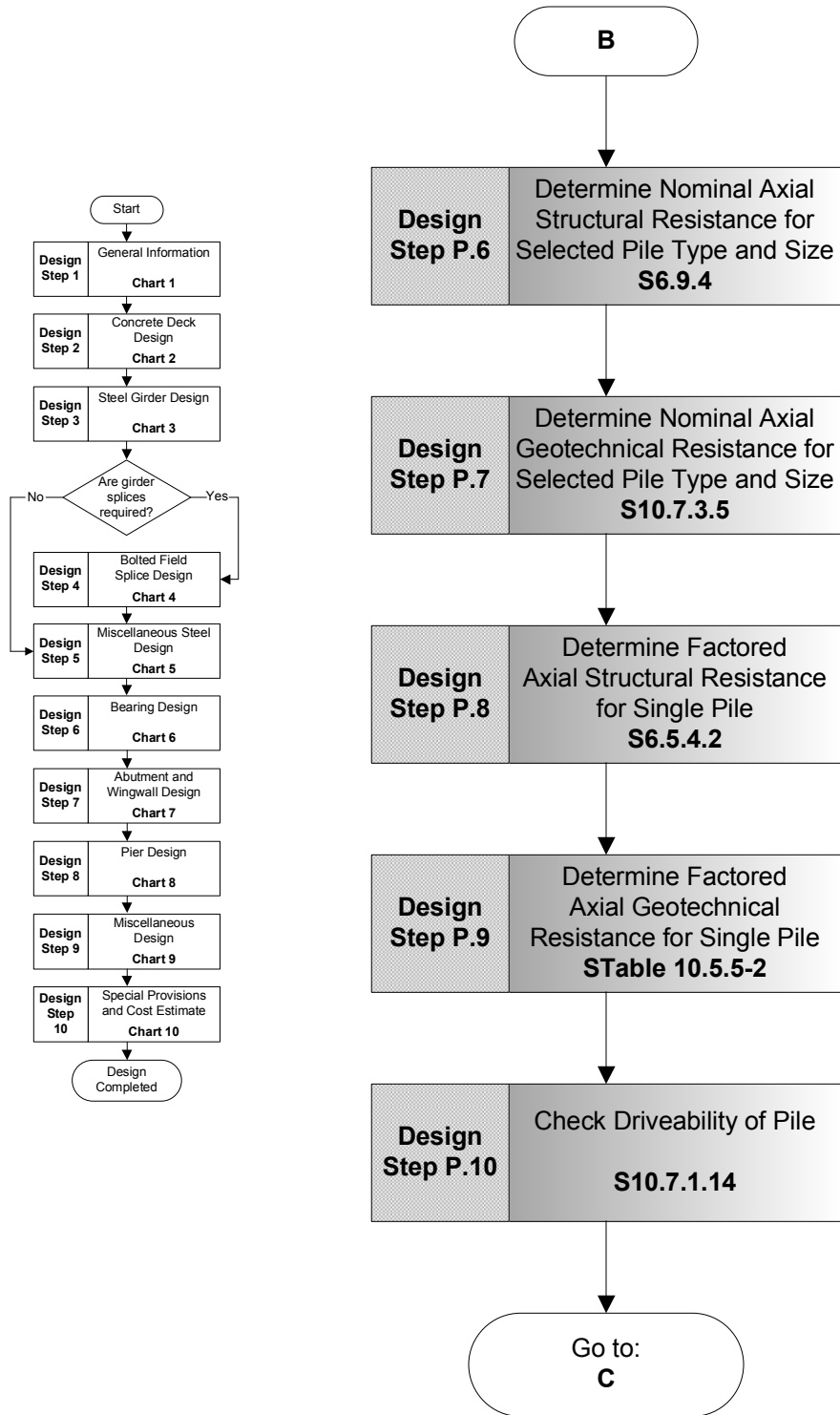

Pile Foundation Design Flowchart (Continued) Chart P

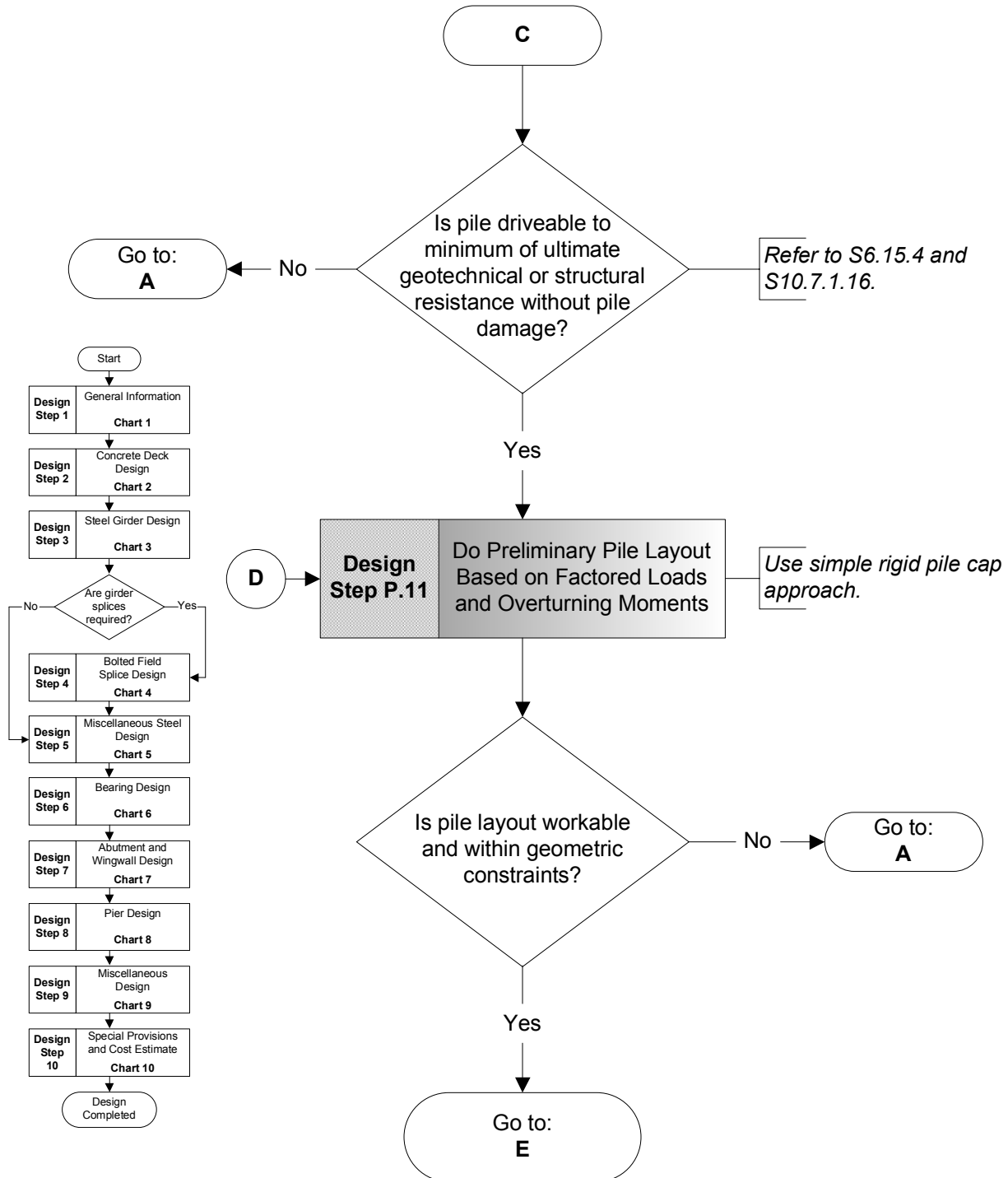

Pile Foundation Design Flowchart (Continued) Chart P

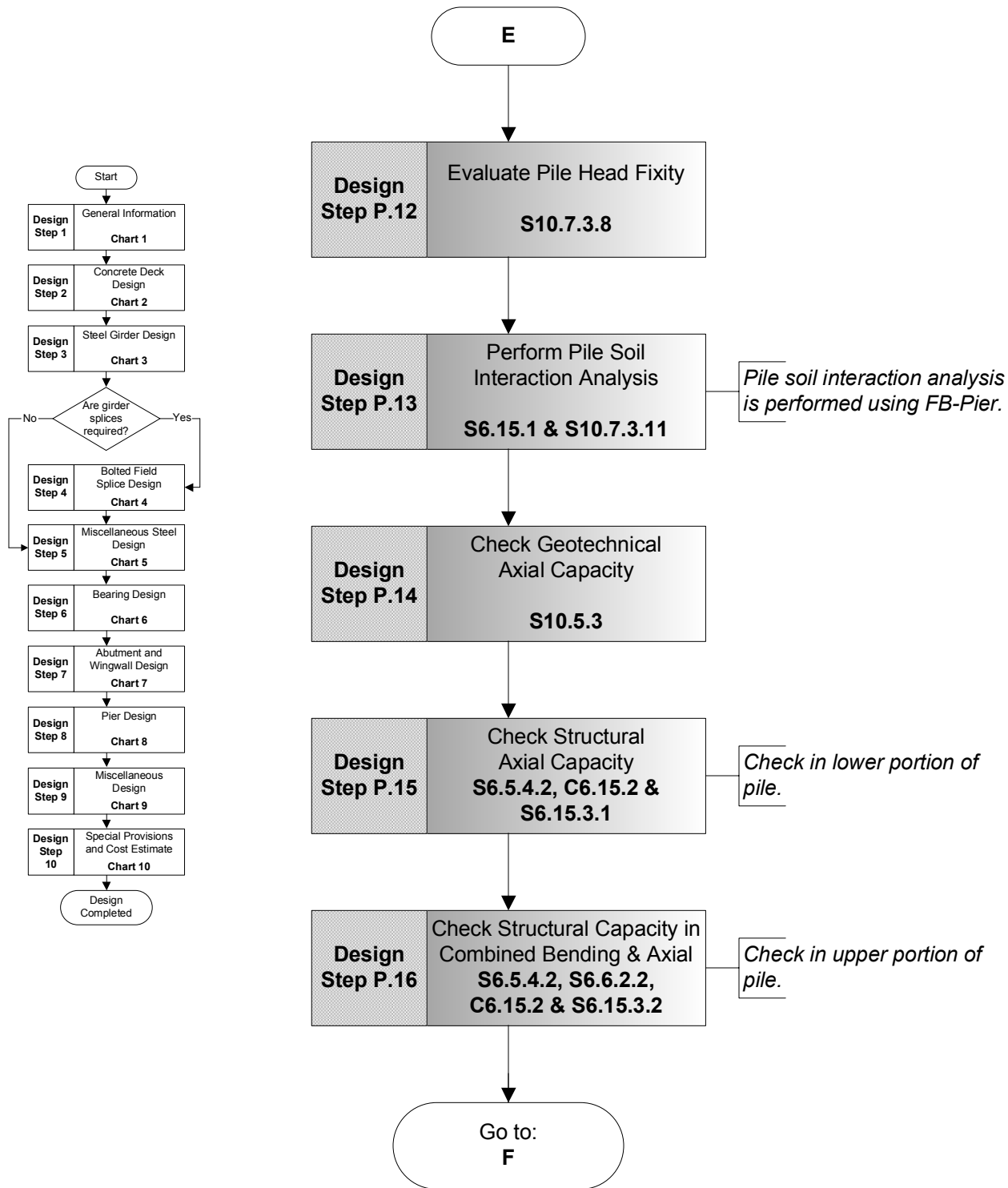

Pile Foundation Design Flowchart (Continued) Chart P

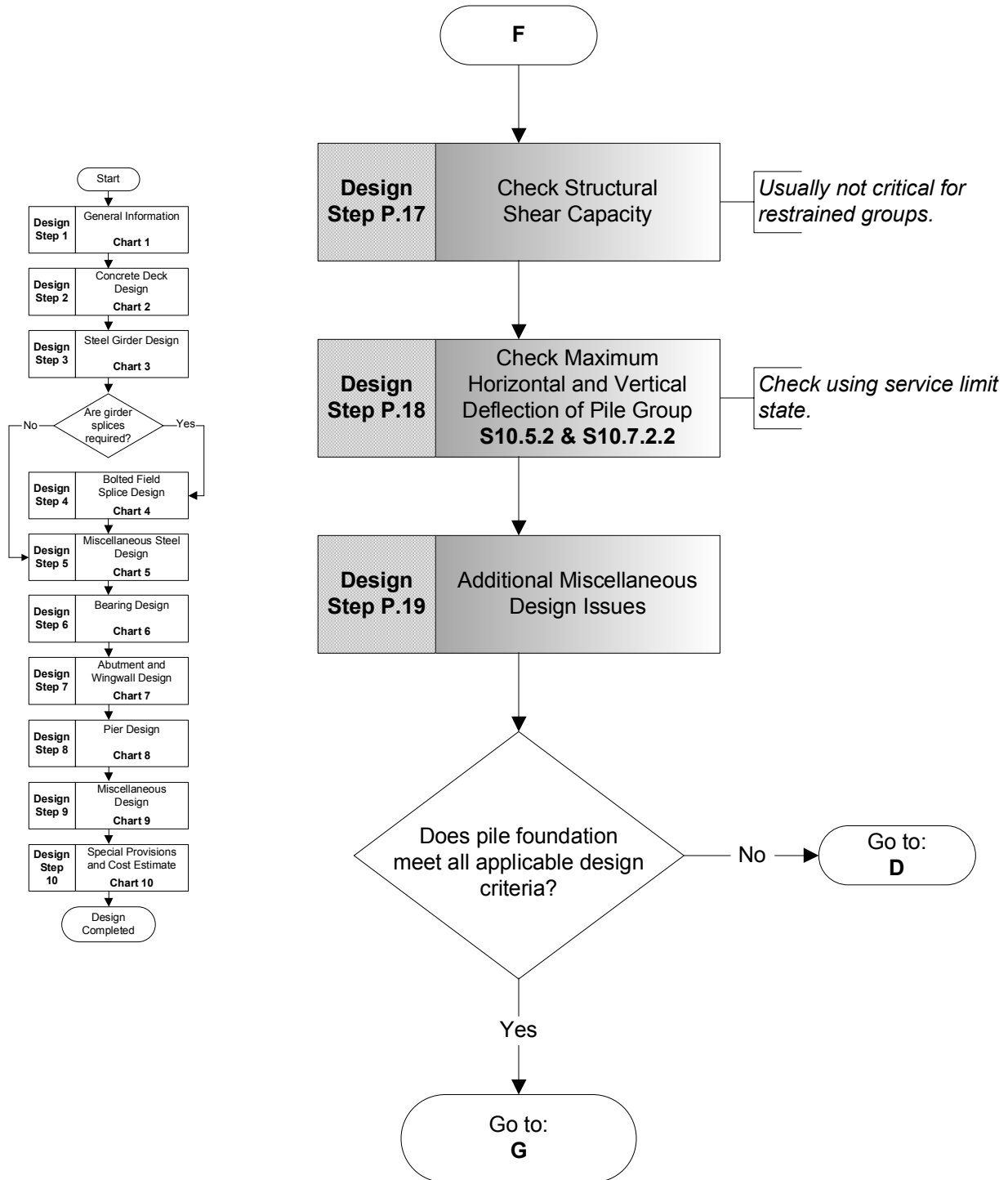

Pile Foundation Design Flowchart (Continued) Chart P

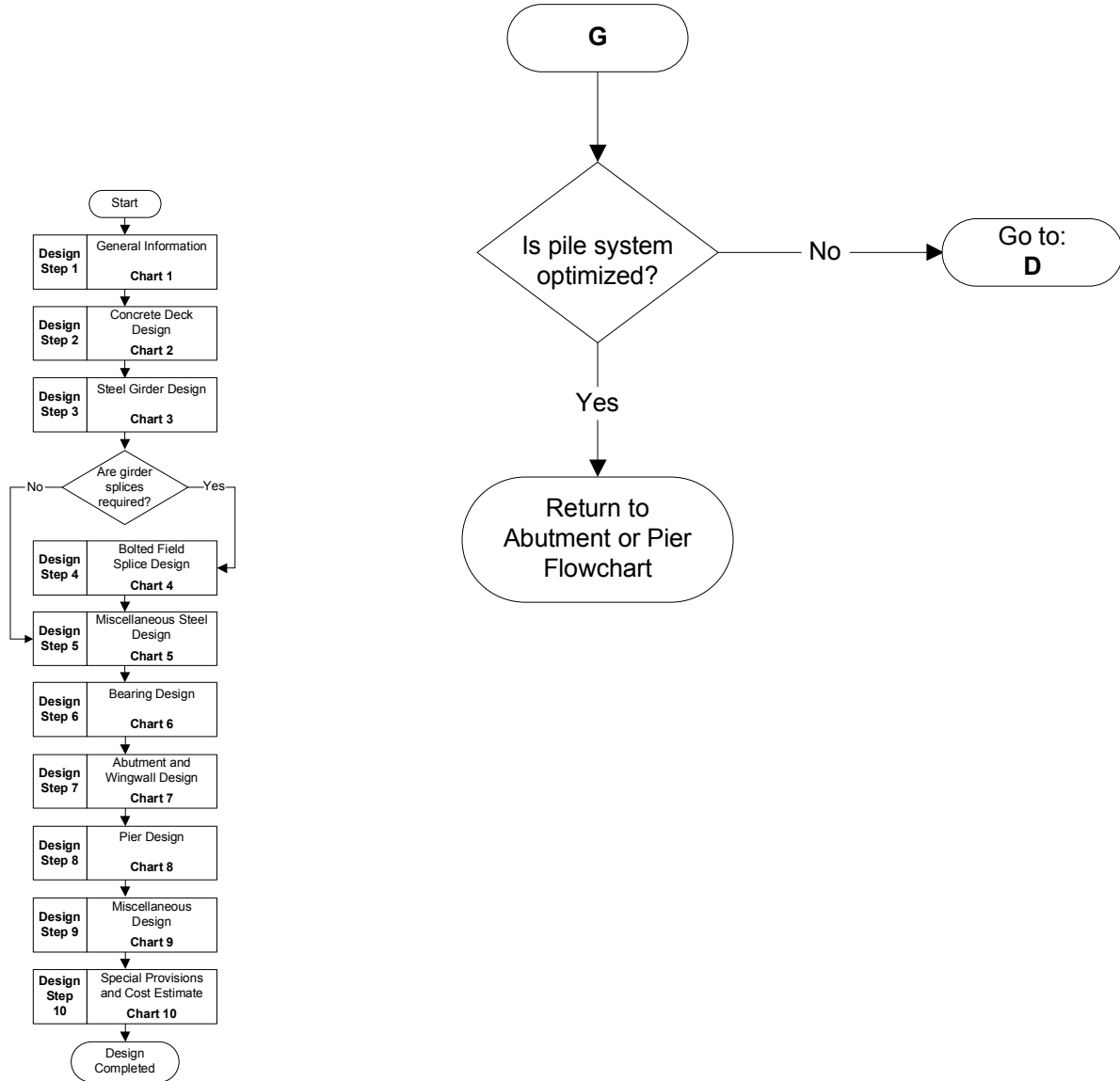

Mathcad Symbols

This LRFD design example was developed using the Mathcad software. This program allows the user to show the mathematical equations that were used, and it also evaluates the equations and gives the results. In order for this program to be able to perform a variety of mathematical calculations, there are certain symbols that have a unique meaning in Mathcad. The following describes some of the Mathcad symbols that are used in this design example.

<u>Symbol</u>	<u>Example</u>	<u>Meaning</u>
■	$y := x^2$ ■	Turning equations off - If an equation is turned off, a small square will appear at the upper right corner of the equation. This is used to prevent a region, such as an equation or a graph, from being calculated. In other words, the evaluation properties of the equation are disabled.
...	$y := 102 + 89 + 1239 \dots$ $+ 436 + 824$	Addition with line break - If an addition equation is wider than the specified margins, the equation can be wrapped, or continued, on the next line. This is represented by three periods in a row at the end of the line.

For more information about the basics of Mathcad worksheets, visit:

<http://www.mathsoft.com>

General Information / Introduction Design Step 1

Table of Contents

	<u>Page</u>
Introduction	1
Design Step 1.1 - Obtain Design Criteria	6
Design Step 1.2 - Obtain Geometry Requirements	9
Design Step 1.3 - Perform Span Arrangement Study	10
Design Step 1.4 - Obtain Geotechnical Recommendations	10
Design Step 1.5 - Perform Type, Size and Location Study	11
Design Step 1.6 - Plan for Bridge Aesthetics	12

Introduction

Design Step 1 is the first of several steps that illustrate the design procedures used for a steel girder bridge. This design step serves as an introduction to this design example and it provides general information about the bridge design.

Purpose

The purpose of this project is to provide a basic design example for a steel girder bridge as an informational tool for the practicing bridge engineer. The example is also aimed at assisting the bridge engineer with the transition from Load Factor Design (LFD) to Load and Resistance Factor Design (LRFD).

AASHTO References

For uniformity and simplicity, this design example is based on the *AASHTO LRFD Bridge Design Specifications* (Second Edition, 1998, including interims for 1999 through 2002). References to the *AASHTO LRFD Bridge Design Specifications* are included throughout the design example. AASHTO references are presented in a dedicated column in the right margin of each page, immediately adjacent to the corresponding design procedure. The following abbreviations are used in the AASHTO references:

S designates specifications
*S**Table* designates a table within the specifications
*S**Figure* designates a figure within the specifications
*S**Equation* designates an equation within the specifications
*S**Appendix* designates an appendix within the specifications
C designates commentary
*C**Table* designates a table within the commentary
*C**Figure* designates a figure within the commentary
*C**Equation* designates an equation within the commentary

State-specific specifications are generally not used in this design example. Any exceptions are clearly noted.

Design Methodology

This design example is based on Load and Resistance Factor Design (LRFD), as presented in the *AASHTO LRFD Bridge Design Specifications*. The following is a general comparison between the primary design methodologies:

Service Load Design (SLD) or Allowable Stress Design (ASD) generally treats each load on the structure as equal from the viewpoint of statistical variability. The safety margin is primarily built into the capacity or resistance of a member rather than the loads.

Load Factor Design (LFD) recognizes that certain design loads, such as live load, are more highly variable than other loads, such as dead load. Therefore, different multipliers are used for each load type. The resistance, based primarily on the estimated peak resistance of a member, must exceed the combined load.

Load and Resistance Factor Design (LRFD) takes into account both the statistical mean resistance and the statistical mean loads. The fundamental LRFD equation includes a load modifier (η), load factors (γ), force effects (Q), a resistance factor (ϕ), a nominal resistance (R_n), and a factored resistance ($R_r = \phi R_n$). LRFD provides a more uniform level of safety throughout the entire bridge, in which the measure of safety is a function of the variability of the loads and the resistance.

Detailed Outline and Flowcharts

Each step in this design example is based on a detailed outline and a series of flowcharts that were developed for this project.

S1.3

The detailed outline and the flowcharts are intended to be comprehensive. They include the primary design steps that would be required for the design of various steel girder bridges.

This design example includes the major steps shown in the detailed outline and flowcharts, but it does not include all design steps. For example, longitudinal stiffener design, girder camber computations, and development of special provisions are included in the detailed outline and the flowcharts. However, their inclusion in the design example is beyond the scope of this project.

Software

An analysis of the superstructure was performed using AASHTO Opis® software. The design moments, shears, and reactions used in the design example are taken from the Opis output, but their computation is not shown in the design example.

Organization of Design Example

To make this reference user-friendly, the numbers and titles of the design steps are consistent between the detailed outline, the flowcharts, and the design example.

In addition to design computations, the design example also includes many tables and figures to illustrate the various design procedures and many AASHTO references. It also includes commentary to explain the design logic in a user-friendly way. A figure is generally provided at the end of each design step, summarizing the design results for that particular bridge element.



Tip Boxes

Tip boxes are used throughout the design example computations to present useful information, common practices, and rules of thumb for the bridge designer. Tip boxes are shaded and include a tip icon, just like this. Tips do not explain what must be done based on the design specifications; rather, they present suggested alternatives for the designer to consider.

Design Parameters

The following is a list of parameters upon which this design example is based:

1. Two span, square, continuous structure configuration
2. Bridge width 44 feet curb to curb (two 12-foot lanes and two 10-foot shoulders)
3. Reinforced concrete deck with overhangs
4. F-shape barriers (standard design)
5. Grade 50 steel throughout
6. Opis superstructure design software to be used to generate superstructure loads
7. Nominally stiffened web with no web tapers
8. Maximum of two flange transitions top and bottom, symmetric about pier centerline
9. Composite deck throughout, with one shear connector design/check
10. Constructibility checks based on a single deck pour
11. Girder to be designed with appropriate fatigue categories (to be identified on sketches)
12. No detailed cross-frame design (general process description provided)
13. One bearing stiffener design
14. Transverse stiffeners designed as required
15. One field splice design (commentary provided on economical locations)
16. One elastomeric bearing design
17. Reinforced concrete cantilever abutments on piles (only one will be designed, including pile computations)
18. One cantilever type wingwall will be designed (all four wingwalls are similar in height and configuration)
19. Reinforced concrete hammerhead pier configuration with pile foundation

Summary of Design Steps

The following is a summary of the major design steps included in this project:

Design Step 1 - General Information

Design Step 2 - Concrete Deck Design

Design Step 3 - Steel Girder Design

Design Step 4 - Bolted Field Splice Design

Design Step 5 - Miscellaneous Steel Design

(i.e., shear connectors, bearing stiffeners, and cross frames)

Design Step 6 - Bearing Design

Design Step 7 - Abutment and Wingwall Design

Design Step 8 - Pier Design

Design Step 9 - Miscellaneous Design

(i.e., approach slabs, deck drainage, and bridge lighting)

Design Step 10 - Special Provisions and Cost Estimate

Design Step P - Pile Foundation Design (part of Design Steps 7 & 8)

To provide a comprehensive summary for general steel bridge design, all of the above design steps are included in the detailed outline and in the flowcharts. However, this design example includes only those steps that are within the scope of this project. Therefore, Design Steps 1 through 8 are included in the design example, but Design Steps 9 and 10 are not.

The following units are defined for use in this design example:

$$K = 1000\text{lb} \quad \text{kcf} = \frac{K}{\text{ft}^3} \quad \text{ksi} = \frac{K}{\text{in}^2}$$

Design Step 1.1 - Obtain Design Criteria

The first step for any bridge design is to establish the design criteria. For this design example, the following is a summary of the primary design criteria:

Design Criteria

Governing specifications:	<i>AASHTO LRFD Bridge Design Specifications</i> (Second Edition, 1998, including interims for 1999 through 2002)	
Design methodology:	Load and Resistance Factor Design (LRFD)	
Live load requirements:	HL-93	S3.6
Deck width:	$W_{deck} = 46.875\text{ft}$	
Roadway width:	$W_{roadway} = 44.0\text{ft}$	
Bridge length:	$L_{total} = 240\cdot\text{ft}$	
Skew angle:	$Skew = 0\text{deg}$	
Structural steel yield strength:	$F_y = 50\text{ksi}$	STable 6.4.1-1
Structural steel tensile strength:	$F_u = 65\text{ksi}$	STable 6.4.1-1
Concrete 28-day compressive strength:	$f'_c = 4.0\text{ksi}$	S5.4.2.1
Reinforcement strength:	$f_y = 60\text{ksi}$	S5.4.3 & S6.10.3.7
Steel density:	$W_s = 0.490\text{kcf}$	STable 3.5.1-1
Concrete density:	$W_c = 0.150\text{kcf}$	STable 3.5.1-1
Parapet weight (each):	$W_{par} = 0.53 \frac{\text{K}}{\text{ft}}$	
Future wearing surface:	$W_{fws} = 0.140\text{kcf}$	STable 3.5.1-1
Future wearing surface thickness:	$t_{fws} = 2.5\text{in}$ (assumed)	

Design Factors from AASHTO LRFD Bridge Design Specifications

The first set of design factors applies to all force effects and is represented by the Greek letter η (eta) in the Specifications. These factors are related to the ductility, redundancy, and operational importance of the structure. A single, combined eta is required for every structure. When a maximum load factor from *S*Table 3.4.1-2 is used, the factored load is multiplied by eta, and when a minimum load factor is used, the factored load is divided by eta. All other loads, factored in accordance with *S*Table 3.4.1-1, are multiplied by eta if a maximum force effect is desired and are divided by eta if a minimum force effect is desired. In this design example, it is assumed that all eta factors are equal to 1.0.

$$\eta_D = 1.0 \quad \eta_R = 1.0 \quad \eta_I = 1.0$$

For loads for which the maximum value of γ_i is appropriate:

$$\eta = \eta_D \cdot \eta_R \cdot \eta_I \quad \text{and} \quad \eta \geq 0.95$$

For loads for which the minimum value of γ_i is appropriate:

$$\eta = \frac{1}{\eta_D \cdot \eta_R \cdot \eta_I} \quad \text{and} \quad \eta \leq 1.00$$

Therefore for this design example, use:

$$\eta = 1.00$$

The following is a summary of other design factors from the *AASHTO LRFD Bridge Design Specifications*. Additional information is provided in the Specifications, and specific section references are provided in the right margin of the design example.

S1.3.2.1

SEquation
1.3.2.1-2SEquation
1.3.2.1-3

Load factors:

Load Combinations and Load Factors								
Limit State	Load Factors							
	DC		DW		LL	IM	WS	WL
	Max.	Min.	Max.	Min.				
Strength I	1.25	0.90	1.50	0.65	1.75	1.75	-	-
Strength III	1.25	0.90	1.50	0.65	-	-	1.40	-
Strength V	1.25	0.90	1.50	0.65	1.35	1.35	0.40	1.00
Service I	1.00	1.00	1.00	1.00	1.00	1.00	0.30	1.00
Service II	1.00	1.00	1.00	1.00	1.30	1.30	-	-
Fatigue	-	-	-	-	0.75	0.75	-	-

Table 1-1 Load Combinations and Load Factors

The abbreviations used in Table 1-1 are as defined in S3.3.2.

The extreme event limit state (including earthquake load) is not considered in this design example.

Resistance factors:

Resistance Factors		
Material	Type of Resistance	Resistance Factor, ϕ
Structural steel	For flexure	$\phi_f = 1.00$
	For shear	$\phi_v = 1.00$
	For axial compression	$\phi_c = 0.90$
	For bearing	$\phi_b = 1.00$
Reinforced concrete	For flexure and tension	$\phi_f = 0.90$
	For shear and torsion	$\phi_v = 0.90$
	For axial compression	$\phi_a = 0.75$
	For compression with flexure	$\phi = 0.75$ to 0.90 (linear interpolation)

Table 1-2 Resistance Factors

*S*Table 3.4.1-1 &
*S*Table 3.4.1-2

*S*5.5.4.2 &
*S*6.5.4.2

Multiple presence factors:

STable 3.6.1.1.2-1

Multiple Presence Factors	
Number of Lanes Loaded	Multiple Presence Factor, m
1	1.20
2	1.00
3	0.85
>3	0.65

Table 1-3 Multiple Presence Factors

Dynamic load allowance:

STable 3.6.2.1-1

Dynamic Load Allowance	
Limit State	Dynamic Load Allowance, IM
Fatigue and Fracture Limit State	15%
All Other Limit States	33%

Table 1-4 Dynamic Load Allowance

Design Step 1.2 - Obtain Geometry Requirements

Geometry requirements for the bridge components are defined by the bridge site and by the highway geometry. Highway geometry constraints include horizontal alignment and vertical alignment.

Horizontal alignment can be tangent, curved, spiral, or a combination of these three geometries.

Vertical alignment can be straight sloped, crest, sag, or a combination of these three geometries.

For this design example, it is assumed that the horizontal alignment geometry is tangent and the vertical alignment geometry is straight sloped.

Design Step 1.3 - Perform Span Arrangement Study

Some clients require a Span Arrangement Study. The Span Arrangement Study includes selecting the bridge type, determining the span arrangement, determining substructure locations, computing span lengths, and checking horizontal clearance for the purpose of approval.

Although a Span Arrangement Study may not be required by the client, these determinations must still be made by the engineer before proceeding to the next design step.

For this design example, the span arrangement is presented in Figure 1-1. This span arrangement was selected to illustrate various design criteria and the established geometry constraints identified for this example.

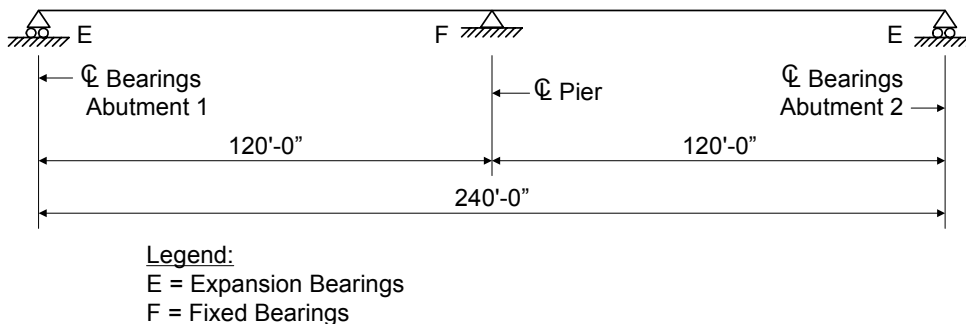

Figure 1-1 Span Arrangement

Design Step 1.4 - Obtain Geotechnical Recommendations

The subsurface conditions must be determined to develop geotechnical recommendations.

Subsurface conditions are commonly determined by taking core borings at the bridge site. The borings provide a wealth of information about the subsurface conditions, all of which is recorded in the boring logs.

It is important to note that the boring log reveals the subsurface conditions for a finite location and not necessarily for the entire bridge site. Therefore, several borings are usually taken at each proposed substructure location. This improves their reliability as a reflection of subsurface conditions at the bridge site, and it allows the engineer to compensate for significant variations in the subsurface profile.

After the subsurface conditions have been explored and documented, a geotechnical engineer must develop foundation type recommendations for all substructures. Foundations can be spread footings, pile foundations, or drilled shafts. Geotechnical recommendations typically include allowable bearing pressure, allowable settlement, and allowable pile resistances (axial and lateral), as well as required safety factors for overturning and sliding.

For this design example, pile foundations are used for all substructure units.

Design Step 1.5 - Perform Type, Size and Location Study

Some clients require a Type, Size and Location study for the purpose of approval. The Type, Size and Location study includes preliminary configurations for the superstructure and substructure components relative to highway geometry constraints and site conditions. Details of this study for the superstructure include selecting the girder types, determining the girder spacing, computing the approximate required girder span and depth, and checking vertical clearance.

Although a Type, Size and Location study may not be required by the client, these determinations must still be made by the engineer before proceeding to the next design step.

For this design example, the superstructure cross section is presented in Figure 1-2. This superstructure cross section was selected to illustrate selected design criteria and the established geometry constraints. When selecting the girder spacing, consideration was given to half-width deck replacement.

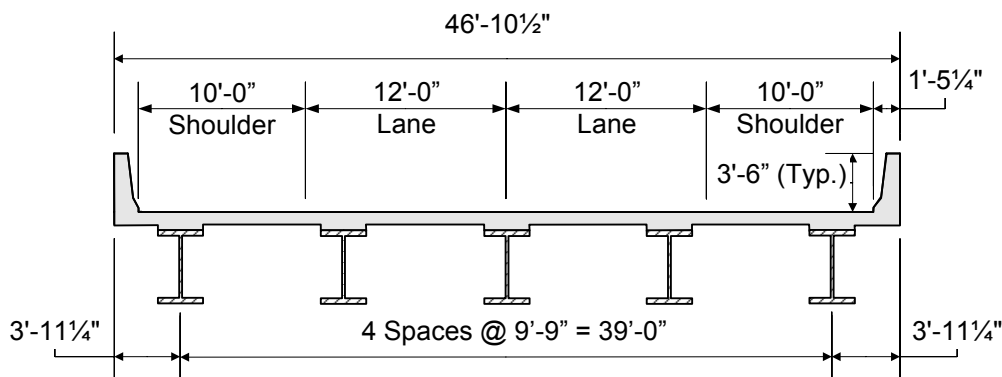

Figure 1-2 Superstructure Cross Section

Design Step 1.6 - Plan for Bridge Aesthetics

Finally, the bridge engineer must consider bridge aesthetics throughout the design process. Special attention to aesthetics should be made during the preliminary stages of the bridge design, before the bridge layout and appearance has been fully determined.

To plan an aesthetic bridge design, the engineer must consider the following parameters:

- Function: Aesthetics is generally enhanced when form follows function.
- Proportion: Provide balanced proportions for members and span lengths.
- Harmony: The parts of the bridge must usually complement each other, and the bridge must usually complement its surroundings.
- Order and rhythm: All members must be tied together in an orderly manner.
- Contrast and texture: Use textured surfaces to reduce visual mass.
- Light and shadow: Careful use of shadow can give the bridge a more slender appearance.

Concrete Deck Design Example Design Step 2

Table of Contents

	<u>Page</u>
Design Step 2.1 - Obtain Design Criteria	2
Design Step 2.2 - Determine Minimum Slab Thickness	5
Design Step 2.3 - Determine Minimum Overhang Thickness	5
Design Step 2.4 - Select Slab and Overhang Thickness	5
Design Step 2.5 - Compute Dead Load Effects	5
Design Step 2.6 - Compute Live Load Effects	7
Design Step 2.7 - Compute Factored Positive and Negative Design Moments	9
Design Step 2.8 - Design for Positive Flexure in Deck	15
Design Step 2.9 - Check for Positive Flexure Cracking under Service Limit State	17
Design Step 2.10 - Design for Negative Flexure in Deck	21
Design Step 2.11 - Check for Negative Flexure Cracking under Service Limit State	22
Design Step 2.12 - Design for Flexure in Deck Overhang	25
Design Step 2.13 - Check for Cracking in Overhang under Service Limit State	42
Design Step 2.14 - Compute Overhang Cut-off Length Requirement	43
Design Step 2.15 - Compute Overhang Development Length	44
Design Step 2.16 - Design Bottom Longitudinal Distribution Reinforcement	46
Design Step 2.17 - Design Top Longitudinal Distribution Reinforcement	47
Design Step 2.18 - Design Longitudinal Reinforcement over Piers	49
Design Step 2.19 - Draw Schematic of Final Concrete Deck Design	51

Design Step 2.1 - Obtain Design Criteria

The first design step for a concrete bridge deck is to choose the correct design criteria. The following concrete deck design criteria are obtained from the typical superstructure cross section shown in Figure 2-1 and from the referenced articles and tables in the *AASHTO LRFD Bridge Design Specifications* (through 2002 interims).

Refer to Design Step 1 for introductory information about this design example. Additional information is presented about the design assumptions, methodology, and criteria for the entire bridge, including the concrete deck.

The next step is to decide which deck design method will be used. In this example, the equivalent strip method will be used. For the equivalent strip method analysis, the girders act as supports, and the deck acts as a simple or continuous beam spanning from support to support. The empirical method could be used for the positive and negative moment interior regions since the cross section meets all the requirements given in S9.7.2.4. However, the empirical method could not be used to design the overhang as stated in S9.7.2.2.

S4.6.2



Overhang Width

The overhang width is generally determined such that the moments and shears in the exterior girder are similar to those in the interior girder. In addition, the overhang is set such that the positive and negative moments in the deck slab are balanced. A common rule of thumb is to make the overhang approximately 0.35 to 0.5 times the girder spacing.

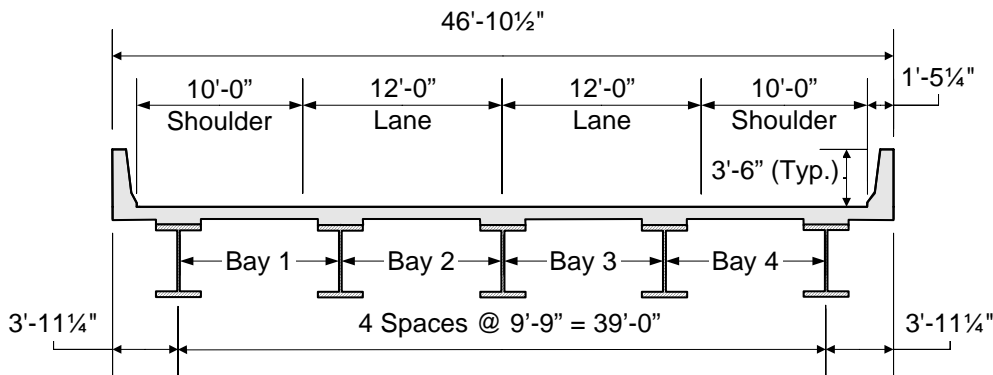

Figure 2-1 Superstructure Cross Section

The following units are defined for use in this design example:

$$K = 1000\text{lb} \quad \text{kcf} = \frac{K}{\text{ft}^3} \quad \text{ksi} = \frac{K}{\text{in}^2}$$

Deck properties:

Girder spacing: $S = 9.75\text{ft}$

Number of girders: $N = 5$

Deck top cover: $\text{Cover}_t = 2.5\text{in}$

Deck bottom cover: $\text{Cover}_b = 1.0\text{in}$

Concrete density: $W_c = 0.150\text{kcf}$

Concrete 28-day compressive strength: $f'_c = 4.0\text{ksi}$

Reinforcement strength: $f_y = 60\text{ksi}$

Future wearing surface: $W_{fws} = 0.140\text{kcf}$

STable 5.12.3-1

STable 5.12.3-1

STable 3.5.1-1

S5.4.2.1

S5.4.3 & S6.10.3.7

STable 3.5.1-1

Parapet properties:

Weight per foot: $W_{\text{par}} = 0.53 \frac{\text{K}}{\text{ft}}$

Width at base: $w_{\text{base}} = 1.4375\text{ft}$

Moment capacity at base*: $M_{\text{co}} = 28.21 \frac{\text{K}\cdot\text{ft}}{\text{ft}}$

Parapet height: $H_{\text{par}} = 3.5\text{ft}$

Critical length of yield line failure pattern*: $L_c = 12.84\text{ft}$ (calculated in Design Step 2.12)

Total transverse resistance of the parapet*: $R_w = 117.40\text{K}$ (calculated in Design Step 2.12)

* Based on parapet properties not included in this design example. See Publication Number FHWA HI-95-017, Load and Resistance Factor Design for Highway Bridges, Participant Notebook, Volume II (Version 3.01), for the method used to compute the parapet properties.

Deck top cover - The concrete top cover is set at 2.5 inches since the bridge deck may be exposed to deicing salts and/or tire stud or chain wear. This includes the 1/2 inch integral wearing surface that is required. *S*Table 5.12.3-1

Deck bottom cover - The concrete bottom cover is set at 1.0 inch since the bridge deck will use reinforcement that is smaller than a #11 bar. *S*Table 5.12.3-1

Concrete 28-day compressive strength - The compressive strength for decks shall not be less than 4.0 KSI. Also, type "AE" concrete should be specified when the deck will be exposed to deicing salts or the freeze-thaw cycle. "AE" concrete has a compressive strength of 4.0 KSI. *S*5.4.2.1
*S*Table C5.4.2.1-1

Future wearing surface density - The future wearing surface density is 0.140 KCF. A 2.5 inch thickness will be assumed. *S*Table 3.5.1-1

Design Step 2.2 - Determine Minimum Slab Thickness

The concrete deck depth cannot be less than 7.0 inches, excluding any provision for grinding, grooving, and sacrificial surface.

S9.7.1.1

Design Step 2.3 - Determine Minimum Overhang Thickness

For concrete deck overhangs supporting concrete parapets or barriers, the minimum deck overhang thickness is:

S13.7.3.1.2

$$t_o = 8.0\text{in}$$

Design Step 2.4 - Select Slab and Overhang Thickness

Once the minimum slab and overhang thicknesses are computed, they can be increased as needed based on client standards and design computations. The following slab and overhang thicknesses will be assumed for this design example:

$$t_s = 8.5\text{in} \quad \text{and} \quad t_o = 9.0\text{in}$$

Design Step 2.5 - Compute Dead Load Effects

The next step is to compute the dead load moments. The dead load moments for the deck slab, parapets, and future wearing surface are tabulated in Table 2-1. The tabulated moments are presented for tenth points for Bays 1 through 4 for a 1-foot strip. The tenth points are based on the equivalent span and not the center-to-center beam spacing.

STable 3.5.1-1

After the dead load moments are computed for the slab, parapets, and future wearing surface, the correct load factors must be identified. The load factors for dead loads are:

STable 3.4.1-2

For slab and parapet:

$$\text{Maximum } \gamma_{pDC\max} = 1.25$$

$$\text{Minimum } \gamma_{pDC\min} = 0.90$$

For future wearing surface:

$$\text{Maximum } \gamma_{pDW\max} = 1.50$$

$$\text{Minimum } \gamma_{pDW\min} = 0.65$$

DISTANCE		0.0	0.1	0.2	0.3	0.4	0.5	0.6	0.7	0.8	0.9	1.0
SLAB DEAD LOAD	BAY 1	-0.74	-0.33	-0.01	0.22	0.36	0.41	0.37	0.24	0.01	-0.30	-0.71
	BAY 2	-0.71	-0.30	0.02	0.24	0.38	0.42	0.38	0.24	0.01	-0.31	-0.72
	BAY 3	-0.72	-0.31	0.01	0.24	0.38	0.42	0.38	0.24	0.02	-0.30	-0.71
	BAY 4	-0.71	-0.30	0.01	0.24	0.37	0.41	0.36	0.22	-0.01	-0.33	-0.74
PARAPET DEAD LOAD	BAY 1	-1.66	-1.45	-1.24	-1.03	-0.82	-0.61	-0.40	-0.19	0.02	0.22	0.43
	BAY 2	0.47	0.40	0.33	0.26	0.19	0.12	0.05	-0.02	-0.09	-0.16	-0.23
	BAY 3	-0.23	-0.16	-0.09	-0.02	0.05	0.12	0.19	0.26	0.33	0.40	0.47
	BAY 4	0.43	0.22	0.02	-0.19	-0.40	-0.61	-0.82	-1.03	-1.24	-1.45	-1.66
FWS DEAD LOAD	BAY 1	-0.06	0.04	0.11	0.15	0.17	0.17	0.14	0.08	0.00	-0.11	-0.24
	BAY 2	-0.24	-0.12	-0.02	0.05	0.09	0.11	0.10	0.07	0.01	-0.07	-0.18
	BAY 3	-0.18	-0.07	0.01	0.07	0.10	0.11	0.09	0.05	-0.02	-0.12	-0.24
	BAY 4	-0.24	-0.11	0.00	0.08	0.14	0.17	0.17	0.15	0.11	0.04	-0.06

Table 2-1 Unfactored Dead Load Moments (K-FT/FT)

Design Step 2.6 - Compute Live Load Effects

Before the live load effects can be computed, the following basic parameters must be defined:

The minimum distance from the center of design vehicle wheel to the inside face of parapet = 1 foot		S3.6.1.3.1
The minimum distance between the wheels of two adjacent design vehicles = 4 feet		S3.6.1.3.1
Dynamic load allowance, IM	$IM = 0.33$	S3.6.2.1-1
Load factor for live load - Strength I	$\gamma_{LL} = 1.75$	S3.4.1-1
Multiple presence factor, m:		S3.6.1.1.2-1
With one lane loaded, m = 1.20		
With two lanes loaded, m = 1.00		
With three lanes loaded, m = 0.85		
Fatigue does not need to be investigated for concrete deck design.		S9.5.3 & S5.5.3.1
Resistance factors for flexure:		
Strength limit state	$\phi_{str} = 0.90$	S5.5.4.2
Service limit state	$\phi_{serv} = 1.00$	S1.3.2.1
Extreme event limit state	$\phi_{ext} = 1.00$	S1.3.2.1

Based on the above information and based on S4.6.2.1, the live load effects for one and two trucks are tabulated in Table 2-2. The live load effects are given for tenth points for Bays 1 through 4. Multiple presence factors are included, but dynamic load allowance is excluded.

		DISTANCE	0.0	0.1	0.2	0.3	0.4	0.5	0.6	0.7	0.8	0.9	1.0
SINGLE TRUCK (MULTIPLE PRESENCE FACTOR OF 1.20 INCLUDED)	MAX. MOMENT	BAY 1	5.62	22.94	30.53	36.44	36.76	31.20	32.48	27.13	18.10	5.68	4.55
		BAY 2	4.07	7.73	20.88	25.56	29.09	28.26	28.00	27.20	18.35	6.01	5.82
		BAY 3	6.04	6.22	18.22	27.37	28.14	28.14	29.28	25.39	20.68	7.84	4.07
		BAY 4	4.55	5.56	11.66	16.19	26.14	31.10	36.62	36.64	30.43	17.03	3.62
		BAY 1	-25.75	-14.45	-3.70	-5.33	-6.96	-8.59	-10.22	-11.84	-13.48	-15.11	-28.51
		BAY 2	-28.38	-19.81	-17.00	-14.18	-11.38	-8.57	-9.20	-11.41	-13.63	-15.84	-27.12
		BAY 3	-27.13	-15.85	-13.63	-11.42	-9.20	-8.27	-10.97	-13.68	-16.39	-19.10	-28.37
		BAY 4	-28.51	-15.11	-13.48	-11.84	-10.22	-8.59	-6.96	-5.33	-3.70	-2.08	-0.44
TWO TRUCKS (MULTIPLE PRESENCE FACTOR OF 1.00 INCLUDED)	MAX. MOMENT	BAY 1	4.36	17.44	22.36	26.35	25.93	21.01	21.21	14.00	4.50	2.06	2.28
		BAY 2	2.04	7.98	17.10	19.26	21.19	21.72	19.58	20.48	15.14	7.19	-2.87
		BAY 3	-2.92	7.32	7.73	16.71	19.41	21.64	21.30	19.15	16.98	8.04	2.28
		BAY 4	2.55	2.30	4.59	10.48	17.96	20.93	25.84	26.46	22.32	12.49	2.66
		BAY 1	-21.47	-12.09	-2.71	-3.24	-4.23	-5.21	-6.20	-7.19	-8.18	-18.32	-29.39
		BAY 2	-29.36	-16.92	-8.53	-1.29	-2.40	-3.51	-4.62	-5.74	-8.01	-17.37	-27.94
		BAY 3	-27.92	-17.38	-8.02	-6.41	-5.17	-3.92	-2.68	-1.44	-2.10	-14.44	-28.83
		BAY 4	-29.40	-18.33	-8.18	-7.19	-6.20	-5.21	-4.22	-3.24	-2.25	-1.26	-0.27

Table 2-2 Unfactored Live Load Moments (Excluding Dynamic Load Allowance) (K-FT)

Design Step 2.7 - Compute Factored Positive and Negative Design Moments

For this example, the design moments will be computed two different ways.

For Method A, the live load portion of the factored design moments will be computed based on the values presented in Table 2-2. Table 2-2 represents a continuous beam analysis of the example deck using a finite element analysis program.

For Method B, the live load portion of the factored design moments will be computed using *S*Table A4.1-1. In *S*Table A4.1-1, moments per unit width include dynamic load allowance and multiple presence factors. The values are tabulated using the equivalent strip method for various bridge cross sections. The values in *S*Table A4.1-1 may be slightly higher than the values from a deck analysis based on the actual number of beams and the actual overhang length. The maximum live load moment is obtained from the table based on the girder spacing. For girder spacings between the values listed in the table, interpolation can be used to get the moment.

*S*Table A4.1-1

Based on Design Step 1, the load modifier eta (η) is 1.0 and will not be shown throughout the design example. Refer to Design Step 1 for a discussion of eta.

S1.3.2.1

Factored Positive Design Moment Using Table 2-2 - Method A

Factored positive live load moment:

The positive, negative, and overhang moment equivalent strip equations are presented in Figure 2-2 below.

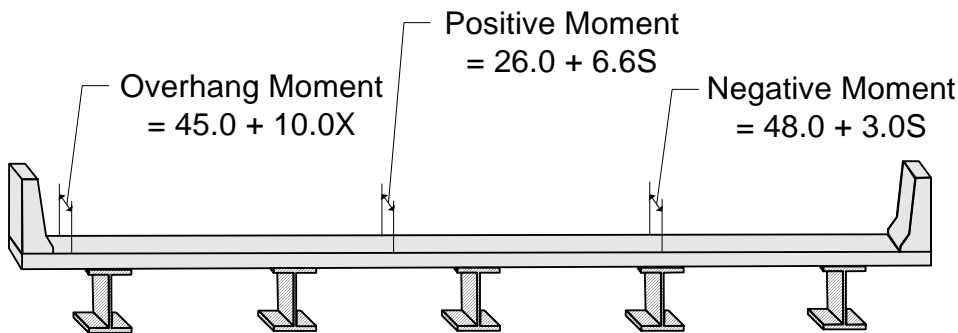

*S*Table 4.6.2.1.3-1

Figure 2-2 Equivalent Strip Equations for Various Parts of the Deck

The width of the equivalent strip for positive moment is:

$$w_{\text{posstripa}} = 26.0 + 6.6S$$

For $S = 9.75 \text{ ft}$

$$w_{\text{posstripa}} = 90.35 \text{ in or } w_{\text{posstripa}} = 7.53 \text{ ft}$$

Based on Table 2-2, the maximum unfactored positive live load moment is 36.76 K-ft, located at 0.4S in Bay 1 for a single truck. The maximum factored positive live load moment is:

$$M_{U_{\text{positiveA}}} = \gamma_{LL} \cdot (1 + IM) \cdot \frac{36.76 \text{ K} \cdot \text{ft}}{w_{\text{posstripa}}}$$

$$M_{U_{\text{positiveA}}} = 11.36 \frac{\text{K} \cdot \text{ft}}{\text{ft}}$$

Factored positive dead load moment:

Based on Table 2-1, the maximum unfactored slab, parapet, and future wearing surface positive dead load moment occurs in Bay 2 at a distance of 0.4S. The maximum factored positive dead load moment is as follows:

$$M_{U_{\text{posdead}}} = \gamma_{pDC_{\text{max}}} \left(0.38 \cdot \frac{\text{K} \cdot \text{ft}}{\text{ft}} \right) + \gamma_{pDC_{\text{max}}} \left(0.19 \cdot \frac{\text{K} \cdot \text{ft}}{\text{ft}} \right) \dots \\ + \gamma_{pDW_{\text{max}}} \left(0.09 \cdot \frac{\text{K} \cdot \text{ft}}{\text{ft}} \right)$$

$$M_{U_{\text{posdead}}} = 0.85 \frac{\text{K} \cdot \text{ft}}{\text{ft}}$$

The total factored positive design moment for Method A is:

$$M_{U_{\text{postotalA}}} = M_{U_{\text{positiveA}}} + M_{U_{\text{posdead}}}$$

$$M_{U_{\text{postotalA}}} = 12.21 \frac{\text{K} \cdot \text{ft}}{\text{ft}}$$

It should be noted that the total maximum factored positive moment is comprised of the maximum factored positive live load moment in Bay 1 at 0.4S and the maximum factored positive dead load moment in Bay 2 at 0.4S. Summing the factored moments in different bays gives a conservative result. The exact way to compute the maximum total factored design moment is by summing the dead and live load moments at each tenth point per bay. However, the method presented here is a simpler and slightly conservative method of finding the maximum total factored moment.

STable 4.6.2.1.3-1

Factored Positive Design Moment Using *S*Table A4.1-1 - Method B

Factored positive live load moment:

For a girder spacing of 9'-9", the maximum unfactored positive live load moment is 6.74 K-ft/ft.

*S*Table A4.1-1

This moment is on a per foot basis and includes dynamic load allowance. The maximum factored positive live load moment is:

$$M_{U_{\text{positiveB}}} = \gamma_{LL} \cdot 6.74 \frac{\text{K}\cdot\text{ft}}{\text{ft}}$$

$$M_{U_{\text{positiveB}}} = 11.80 \frac{\text{K}\cdot\text{ft}}{\text{ft}}$$

Factored positive dead load moment:

The factored positive dead load moment for Method B is the same as that for Method A:

$$M_{U_{\text{posdead}}} = 0.85 \frac{\text{K}\cdot\text{ft}}{\text{ft}}$$

The total factored positive design moment for Method B is:

$$M_{U_{\text{postotalB}}} = M_{U_{\text{positiveB}}} + M_{U_{\text{posdead}}}$$

$$M_{U_{\text{postotalB}}} = 12.64 \frac{\text{K}\cdot\text{ft}}{\text{ft}}$$

Comparing Methods A and B, the difference between the total factored design moment for the two methods is:

$$\frac{M_{U_{\text{postotalB}}} - M_{U_{\text{postotalA}}}}{M_{U_{\text{postotalB}}}} = 3.4\%$$

**Method A or Method B**

It can be seen that the tabulated values based on *S*Table A4.1-1 (Method B) are slightly greater than the computed live load values using a finite element analysis program (Method A). For real world deck design, Method B would be preferred over Method A due to the amount of time that would be saved by not having to develop a finite element model. Since the time was spent to develop the finite element model for this deck design, the Method A values will be used.

Factored Negative Design Moment Using Table 2-2 - Method A

Factored negative live load moment:

The deck design section for a steel beam for negative moments and shear forces is taken as one-quarter of the top flange width from the centerline of the web.

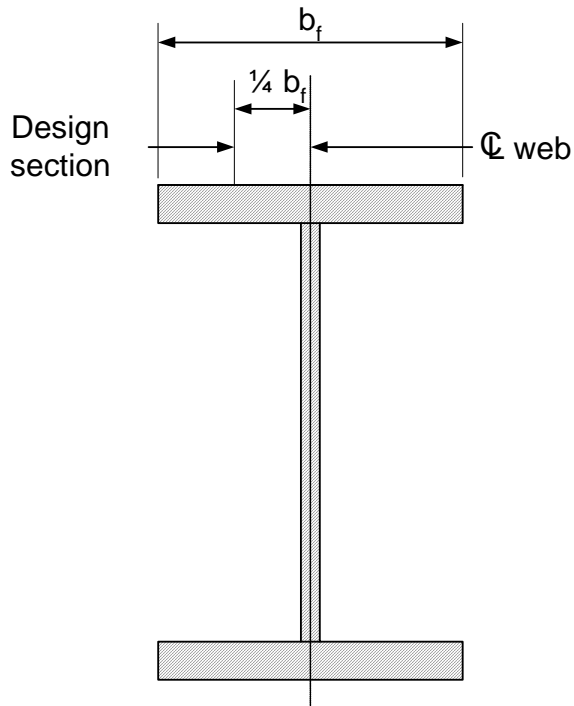

Figure 2-3 Location of Design Section

Assume $b_f = 1.0\text{ft}$

$$\frac{1}{4}b_f = 0.25\text{ft}$$

The width of the equivalent strip for negative moment is:

$$w_{\text{negstripa}} = 48.0 + 3.0S^{\text{■}}$$

$$w_{\text{negstripa}} = 77.25\text{in or } w_{\text{negstripa}} = 6.44\text{ft}$$

S4.6.2.1.6

S4.6.2.1.6

S4.6.2.1.3-1

Based on Table 2-2, the maximum unfactored negative live load moment is -29.40 K-ft, located at 0.0S in Bay 4 for two trucks. The maximum factored negative live load moment is:

$$M_{U_{negliveA}} = \gamma_{LL} \cdot (1 + IM) \cdot \frac{-29.40 \text{ K}\cdot\text{ft}}{W_{negstripa}}$$

$$M_{U_{negliveA}} = -10.63 \frac{\text{K}\cdot\text{ft}}{\text{ft}}$$

Factored negative dead load moment:

From Table 2-1, the maximum unfactored negative dead load moment occurs in Bay 4 at a distance of 1.0S. The maximum factored negative dead load moment is as follows:

$$\begin{aligned} M_{U_{negdead}} = & \gamma_{pDCmax} \cdot \left(-0.74 \cdot \frac{\text{K}\cdot\text{ft}}{\text{ft}} \right) \dots \\ & + \gamma_{pDCmax} \cdot \left(-1.66 \cdot \frac{\text{K}\cdot\text{ft}}{\text{ft}} \right) \dots \\ & + \gamma_{pDWmax} \cdot \left(-0.06 \cdot \frac{\text{K}\cdot\text{ft}}{\text{ft}} \right) \end{aligned}$$

$$M_{U_{negdead}} = -3.09 \frac{\text{K}\cdot\text{ft}}{\text{ft}}$$

The total factored negative design moment for Method A is:

$$M_{U_{negtotalA}} = M_{U_{negliveA}} + M_{U_{negdead}}$$

$$M_{U_{negtotalA}} = -13.72 \frac{\text{K}\cdot\text{ft}}{\text{ft}}$$

Factored Negative Design Moment Using *S*Table A4.1-1 - Method B

Factored negative live load moment:

For a girder spacing of 9'-9" and a 3" distance from the centerline of girder to the design section, the maximum unfactored negative live load moment is 6.65 K-ft/ft.

*S*Table A4.1-1

If the distance from the centerline of the girder to the design section does not match one of the distances given in the table, the design moment can be obtained by interpolation. As stated earlier, these moments are on a per foot basis and include dynamic load allowance.

The maximum factored negative live load moment is:

$$M_{U_{negliveB}} = \gamma_{LL} \cdot -6.65 \frac{K \cdot ft}{ft}$$

$$M_{U_{negliveB}} = -11.64 \frac{K \cdot ft}{ft}$$

Factored negative dead load moment:

The factored negative dead load moment for Method B is the same as that for Method A:

$$M_{U_{negdead}} = -3.09 \frac{K \cdot ft}{ft}$$

The total factored negative design moment for Method B is:

$$M_{U_{negtotalB}} = M_{U_{negliveB}} + M_{U_{negdead}}$$

$$M_{U_{negtotalB}} = -14.73 \frac{K \cdot ft}{ft}$$

Comparing Methods A and B, the difference between the total factored design moment for the two methods is:

$$\frac{M_{U_{negtotalB}} - M_{U_{negtotalA}}}{M_{U_{negtotalB}}} = 6.8\%$$



Method A or Method B

It can be seen that the tabulated values based on *S*Table A4.1-1 (Method B) are slightly greater than the computed live load values using a finite element analysis program (Method A). For real world deck design, Method B would be preferred over Method A due to the amount of time that would be saved by not having to develop a finite element model. Since the time was spent to develop the finite element model for this deck design, the Method A values will be used.

Design Step 2.8 - Design for Positive Flexure in Deck

The first step in designing the positive flexure steel is to assume a bar size. From this bar size, the required area of steel (A_s) can be calculated. Once the required area of steel is known, the required bar spacing can be calculated.

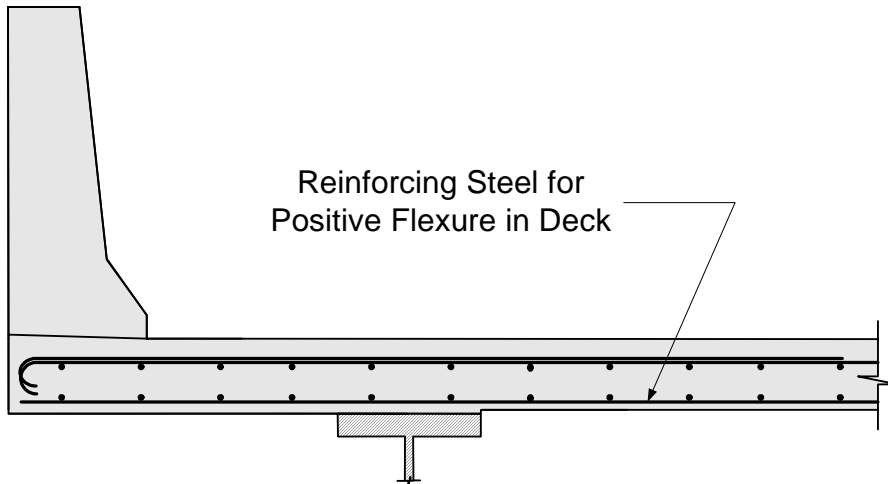

Figure 2-4 Reinforcing Steel for Positive Flexure in Deck

Assume #5 bars:

$$\text{bar_diam} = 0.625\text{in}$$

$$\text{bar_area} = 0.31\text{in}^2$$

Effective depth, d_e = total slab thickness - bottom cover - 1/2 bar diameter - top integral wearing surface

$$d_e = t_s - \text{Cover}_b - \frac{\text{bar_diam}}{2} - 0.5\text{in}$$

$$d_e = 6.69\text{in}$$

Solve for the required amount of reinforcing steel, as follows:

$$\phi_f = 0.90$$

$$b = 12\text{in}$$

$$R_n = \frac{M_{u\text{posttotalA}} \cdot 12\text{in}}{(\phi_f \cdot b \cdot d_e^2)} \quad R_n = 0.30 \frac{\text{K}}{\text{in}^2}$$

S5.5.4.2.1

$$\rho = 0.85 \left(\frac{f'_c}{f_y} \right) \left[1.0 - \sqrt{1.0 - \frac{(2 \cdot R_n)}{(0.85 \cdot f'_c)}} \right]$$

$$\rho = 0.00530$$

Note: The above two equations are derived formulas that can be found in most reinforced concrete textbooks.

$$A_s = \rho \cdot \frac{b}{ft} \cdot d_e \quad A_s = 0.43 \frac{\text{in}^2}{ft}$$

$$\text{Required bar spacing} = \frac{\text{bar_area}}{A_s} = 8.7 \text{ in}$$

Use #5 bars @ $\text{bar_space} = 8.0 \text{ in}$

Once the bar size and spacing are known, the maximum reinforcement limit must be checked.

S5.7.3.3.1

$$T = \text{bar_area} \cdot f_y \quad T = 18.60 \text{ K}$$

$$a = \frac{T}{0.85 \cdot f'_c \cdot \text{bar_space}} \quad a = 0.68 \text{ in}$$

$$\beta_1 = 0.85$$

S5.7.2.2

$$c = \frac{a}{\beta_1} \quad c = 0.80 \text{ in}$$

S5.7.2.2

$$\frac{c}{d_e} = 0.12 \quad \text{where} \quad \frac{c}{d_e} \leq 0.42$$

S5.7.3.3.1

$$0.12 \leq 0.42 \quad \text{OK}$$

Design Step 2.9 - Check for Positive Flexure Cracking under Service Limit State

The control of cracking by distribution of reinforcement must be checked.

S5.7.3.4

For members in severe exposure conditions: $Z = 130 \frac{\text{K}}{\text{in}}$

Thickness of clear cover used to compute d_c should not be greater than 2 inches:

$$d_c = 1\text{in} + \frac{\text{bar_diam}}{2}$$

$$d_c = 1.31\text{in}$$

Concrete area with centroid the same as transverse bar and bounded by the cross section and line parallel to neutral axis:

$$A_c = 2 \cdot (d_c) \cdot \text{bar_space}$$

$$A_c = 21.00\text{in}^2$$

The equation that gives the allowable reinforcement service load stress for crack control is:

$$f_{sa} = \frac{Z}{(d_c \cdot A_c)^{\frac{1}{3}}} \quad \text{where} \quad f_{sa} \leq 0.6 \cdot f_y$$

$$f_{sa} = 43.04\text{ksi}$$

$$0.6f_y = 36.00\text{ksi}$$

$$\text{Use } f_{sa} = 36.00\text{ksi}$$

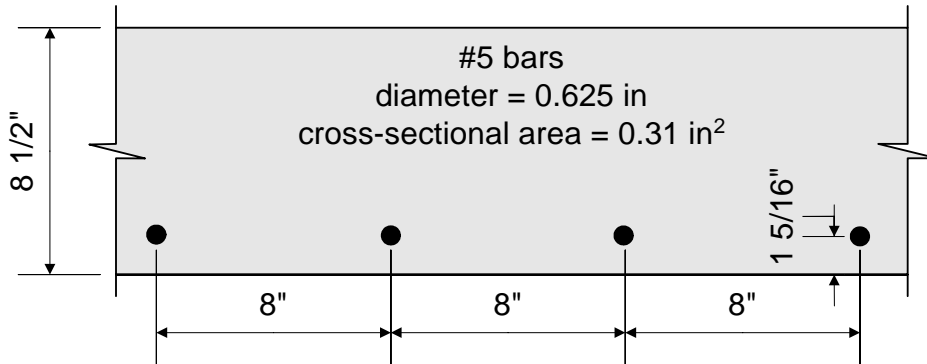

Figure 2-5 Bottom Transverse Reinforcement

$$E_s = 29000 \text{ ksi}$$

S5.4.3.2

$$E_c = 3640 \text{ ksi}$$

S5.4.2.4

$$n = \frac{E_s}{E_c} \quad n = 7.97$$

$$\text{Use } n = 8$$

Service positive live load moment:

Based on Table 2-2, the maximum unfactored positive live load moment is 36.76 K-ft, located at 0.4S in Bay 1 for a single truck. The maximum service positive live load moment is computed as follows:

$$\gamma_{LL} = 1.0$$

$$M_{u_{\text{positiveA}}} = \gamma_{LL} \cdot (1 + IM) \cdot \frac{36.76 \text{ K} \cdot \text{ft}}{w_{\text{posstripa}}}$$

$$M_{u_{\text{positiveA}}} = 6.49 \frac{\text{K} \cdot \text{ft}}{\text{ft}}$$

Service positive dead load moment:

From Table 2-1, the maximum unfactored slab, parapet, and future wearing surface positive dead load moment occurs in Bay 2 at a distance of 0.4S. The maximum service positive dead load moment is computed as follows:

$$\gamma_{pDCserv} = 1.0$$

$$\gamma_{pDWserv} = 1.0$$

$$\begin{aligned} M_{u_{posdead}} = & \gamma_{pDCserv} \cdot \left(0.38 \cdot \frac{K \cdot ft}{ft} \right) + \gamma_{pDCserv} \cdot \left(0.19 \cdot \frac{K \cdot ft}{ft} \right) \dots \\ & + \gamma_{pDWserv} \cdot \left(0.09 \cdot \frac{K \cdot ft}{ft} \right) \end{aligned}$$

$$M_{u_{posdead}} = 0.66 \frac{K \cdot ft}{ft}$$

The total service positive design moment is:

$$M_{u_{postotalA}} = M_{u_{positiveA}} + M_{u_{posdead}}$$

$$M_{u_{postotalA}} = 7.15 \frac{K \cdot ft}{ft}$$

To solve for the actual stress in the reinforcement, the transformed moment of inertia and the distance from the neutral axis to the centroid of the reinforcement must be computed:

$$d_e = 6.69 \text{ in} \quad A_s = 0.465 \frac{\text{in}^2}{\text{ft}} \quad n = 8$$

$$\rho = \frac{A_s}{\frac{b}{ft} \cdot d_e} \quad \rho = 0.00579$$

$$k = \sqrt{(\rho \cdot n)^2 + (2 \cdot \rho \cdot n)} - \rho \cdot n$$

$$k = 0.262$$

$$k \cdot d_e = 1.75 \text{ in}$$

STable 3.4.1-1

STable 3.4.1-1

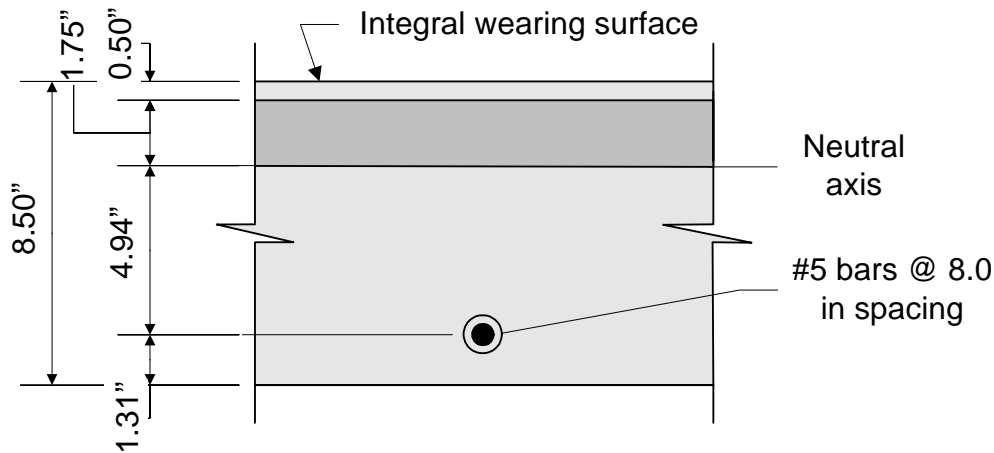

Figure 2-6 Crack Control for Positive Reinforcement under Live Loads

Once kd_e is known, the transformed moment of inertia can be computed:

$$d_e = 6.69 \text{ in}$$

$$A_s = 0.465 \frac{\text{in}^2}{\text{ft}}$$

$$I_t = \frac{1}{3} \cdot \left(12 \frac{\text{in}}{\text{ft}} \right) \cdot (k \cdot d_e)^3 + n \cdot A_s \cdot (d_e - k \cdot d_e)^2$$

$$I_t = 112.22 \frac{\text{in}^4}{\text{ft}}$$

Now, the actual stress in the reinforcement can be computed:

$$M_{u\text{posttotalA}} = 7.15 \text{ K} \cdot \frac{\text{ft}}{\text{ft}} \quad y = d_e - k \cdot d_e \quad y = 4.94 \text{ in}$$

$$f_s = \frac{n \cdot \left(M_{u\text{posttotalA}} \cdot 12 \frac{\text{in}}{\text{ft}} \cdot y \right)}{I_t}$$

$$f_s = 30.23 \text{ ksi} \quad f_{sa} > f_s \quad \text{OK}$$

Design Step 2.10 - Design for Negative Flexure in Deck

The negative flexure reinforcing steel design is similar to the positive flexure reinforcing steel design.

S4.6.2.1

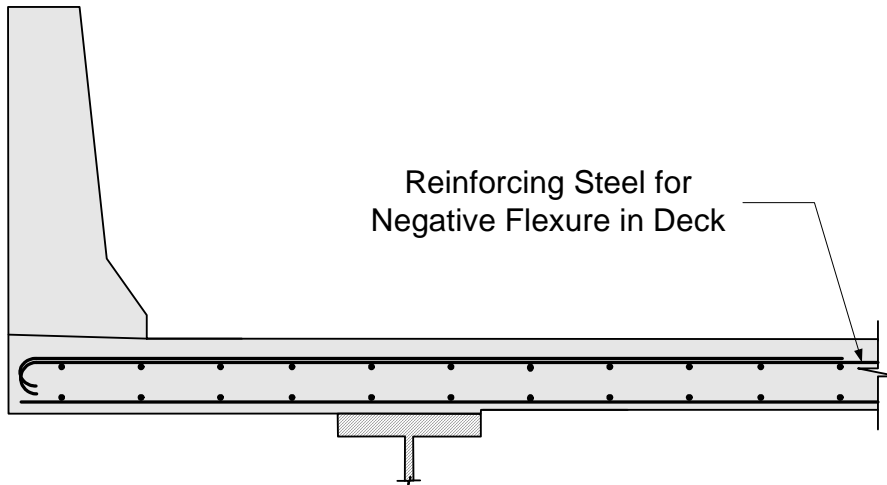

Figure 2-7 Reinforcing Steel for Negative Flexure in Deck

Assume #5 bars:

$$\text{bar_diam} = 0.625\text{in}$$

$$\text{bar_area} = 0.31\text{in}^2$$

Effective depth, $d_e = \text{total slab thickness} - \text{top cover} - 1/2 \text{ bar diameter}$

$$d_e = t_s - \text{Cover}_t - \frac{\text{bar_diam}}{2} \quad d_e = 5.69\text{in}$$

Solve for the required amount of reinforcing steel, as follows:

$$\phi_f = 0.90$$

$$b = 12\text{in}$$

$$R_n = \frac{-M_{u\text{negtotal}} \cdot 12\text{in}}{(\phi_f \cdot b \cdot d_e^2)} \quad R_n = 0.47 \frac{\text{K}}{\text{in}^2}$$

$$\rho = 0.85 \left(\frac{f'_c}{f_y} \right) \left[1.0 - \sqrt{1.0 - \frac{(2 \cdot R_n)}{(0.85 \cdot f'_c)}} \right]$$

$$\rho = 0.00849$$

S5.5.4.2.1

$$A_s = \rho \cdot \frac{b}{ft} \cdot d_e \quad A_s = 0.58 \frac{\text{in}^2}{ft}$$

$$\text{Required bar spacing} = \frac{\text{bar_area}}{A_s} = 6.4 \text{ in}$$

Use #5 bars @ bar_space = 6.0in

Once the bar size and spacing are known, the maximum reinforcement limit must be checked.

S5.7.3.3.1

$$T = \text{bar_area} \cdot f_y \quad T = 18.60 \text{ K}$$

$$a = \frac{T}{0.85 \cdot f'_c \cdot \text{bar_space}} \quad a = 0.91 \text{ in}$$

$$\beta_1 = 0.85$$

S5.7.2.2

$$c = \frac{a}{\beta_1} \quad c = 1.07 \text{ in}$$

S5.7.2.2

$$\frac{c}{d_e} = 0.19 \quad \text{where} \quad \frac{c}{d_e} \leq 0.42$$

S5.7.3.3.1

$$0.19 \leq 0.42 \quad \text{OK}$$

Design Step 2.11 - Check for Negative Flexure Cracking under Service Limit State

Similar to the positive flexure reinforcement, the control of cracking by distribution of reinforcement must be checked.

S5.7.3.4

$$Z = 130 \frac{\text{K}}{\text{in}}$$

Note: clear cover is greater than 2.0 inches; therefore, use clear cover equals 2.0 inches.

S5.7.3.4

$$d_c = 2\text{in} + \frac{\text{bar_diam}}{2} \quad d_c = 2.31\text{ in}$$

$$A_c = 2 \cdot (d_c) \cdot \text{bar_space} \quad A_c = 27.75\text{ in}^2$$

$$f_{sa} = \frac{Z}{(d_c \cdot A_c)^{\frac{1}{3}}} \quad \text{where} \quad f_{sa} \leq 0.6 \cdot f_y$$

$$f_{sa} = 32.47\text{ ksi} \quad 0.6f_y = 36.00\text{ ksi}$$

$$\text{Use } f_{sa} = 32.47\text{ ksi}$$

Service negative live load moment:

From Table 2-2, the maximum unfactored negative live load moment is -29.40 K-ft, located at 0.0S in Bay 4 for two trucks. The maximum service negative live load moment is:

$$\gamma_{LL} = 1.0$$

$$M_{\text{unegliveA}} = \gamma_{LL} \cdot (1 + \text{IM}) \cdot \frac{-29.40\text{ K}\cdot\text{ft}}{W_{\text{negstripA}}}$$

$$M_{\text{unegliveA}} = -6.07 \frac{\text{K}\cdot\text{ft}}{\text{ft}}$$

STable 3.4.1-1

Service negative dead load moment:

From Table 2-1, the maximum unfactored negative dead load moment occurs in Bay 4 at a distance of 1.0S. The maximum service negative dead load moment is computed as follows:

$$\gamma_{pDC\text{service}} = 1.0 \quad \gamma_{pDW\text{service}} = 1.0$$

$$M_{\text{unegdead}} = \gamma_{pDC\text{service}} \cdot \left(-0.74 \cdot \frac{\text{K}\cdot\text{ft}}{\text{ft}} - 1.66 \cdot \frac{\text{K}\cdot\text{ft}}{\text{ft}} \right) \dots \\ + \gamma_{pDW\text{service}} \cdot \left(-0.06 \cdot \frac{\text{K}\cdot\text{ft}}{\text{ft}} \right)$$

STable 3.4.1-1

$$M_{u_{\text{negdead}}} = -2.46 \frac{\text{K}\cdot\text{ft}}{\text{ft}}$$

The total service negative design moment is:

$$M_{u_{\text{negtotalA}}} = M_{u_{\text{negliveA}}} + M_{u_{\text{negdead}}}$$

$$M_{u_{\text{negtotalA}}} = -8.53 \frac{\text{K}\cdot\text{ft}}{\text{ft}}$$

$$d_e = 5.69\text{in} \quad A_s = 0.62 \frac{\text{in}^2}{\text{ft}} \quad n = 8$$

$$\rho = \frac{A_s}{\frac{b}{\text{ft}} \cdot d_e} \quad \rho = 0.00908$$

$$k = \sqrt{(\rho \cdot n)^2 + (2 \cdot \rho \cdot n)} - \rho \cdot n$$

$$k = 0.315$$

$$k \cdot d_e = 1.79\text{in}$$

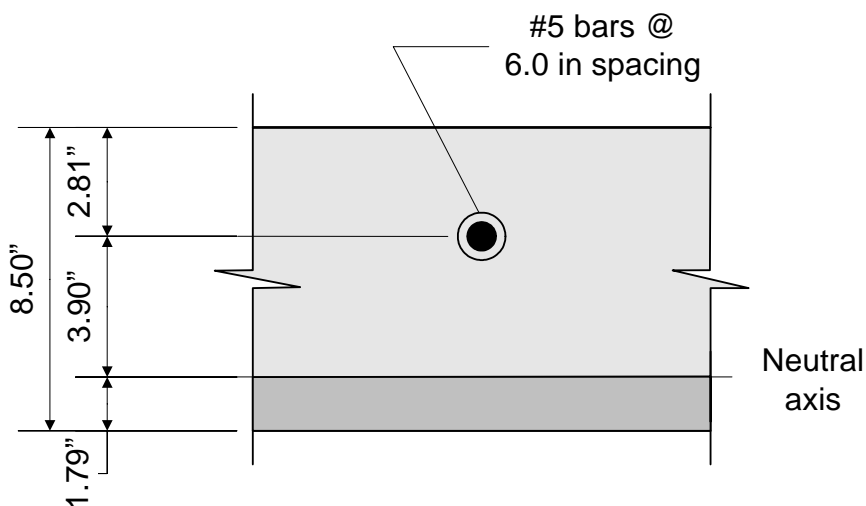

Figure 2-8 Crack Control for Negative Reinforcement under Live Loads

Once $k d_e$ is known, the transformed moment of inertia can be computed:

$$d_e = 5.69 \text{ in}$$

$$A_s = 0.62 \frac{\text{in}^2}{\text{ft}}$$

$$I_t = \frac{1}{3} \cdot \left(12 \frac{\text{in}}{\text{ft}}\right) \cdot (k \cdot d_e)^3 + n \cdot A_s \cdot (d_e - k \cdot d_e)^2$$

$$I_t = 98.38 \frac{\text{in}^4}{\text{ft}}$$

Now, the actual stress in the reinforcement can be computed:

$$M_{\text{negtotalA}} = -8.53 \text{ K} \cdot \frac{\text{ft}}{\text{ft}} \quad y = d_e - k \cdot d_e \quad y = 3.90 \text{ in}$$

$$f_s = \frac{n \cdot \left(-M_{\text{negtotalA}} \cdot 12 \frac{\text{in}}{\text{ft}} \cdot y \right)}{I_t}$$

$$f_s = 32.44 \text{ ksi} \quad f_{sa} > f_s \quad \text{OK}$$

Design Step 2.12 - Design for Flexure in Deck Overhang

Bridge deck overhangs must be designed to satisfy three different design cases. In the first design case, the overhang must be designed for horizontal (transverse and longitudinal) vehicular collision forces. For the second design case, the overhang must be designed to resist the vertical collision force. Finally, for the third design case, the overhang must be designed for dead and live loads. For Design Cases 1 and 2, the design forces are for the extreme event limit state. For Design Case 3, the design forces are for the strength limit state. Also, the deck overhang region must be designed to have a resistance larger than the actual resistance of the concrete parapet.

SA13.4.1

CA13.3.1

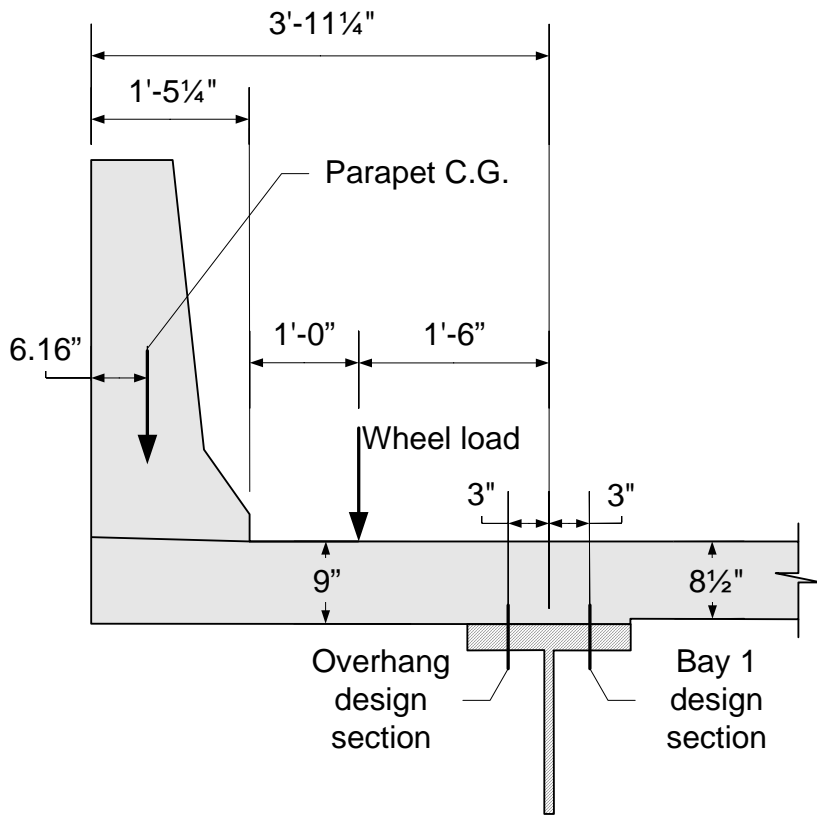

Figure 2-9 Deck Overhang Dimensions and Live Loading

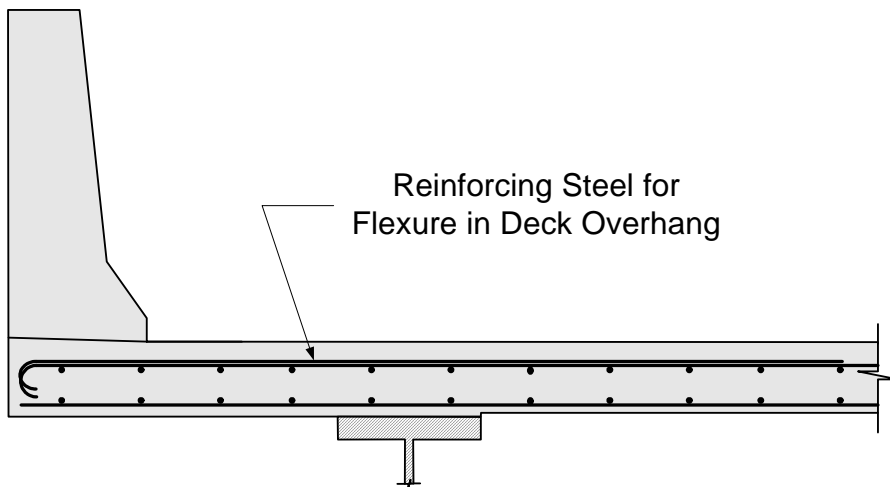

Figure 2-10 Reinforcing Steel for Flexure in Deck Overhang

Design Case 1 - Design Overhang for Horizontal Vehicular Collision Force

The horizontal vehicular collision force must be checked at the inside face of the parapet, at the design section in the overhang, and at the design section in the first bay.

Case 1A - Check at Inside Face of Parapet

The overhang must be designed for the vehicular collision plus dead load moment acting concurrently with the axial tension force from vehicular collision.

For the extreme event limit state:

$$\phi_{\text{ext}} = 1.0$$

$$\gamma_{\text{pDC}} = 1.25$$

$$M_{\text{co}} = 28.21 \text{ K} \cdot \frac{\text{ft}}{\text{ft}} \quad (\text{see parapet properties})$$

$$M_{\text{DCdeck}} = \gamma_{\text{pDC}} \cdot \frac{\left[\left(\frac{9 \text{ in}}{12 \frac{\text{in}}{\text{ft}}} \right) \cdot (0.150 \text{ kcf}) \cdot (1.4375 \text{ ft})^2 \right]}{2}$$

$$M_{\text{DCdeck}} = 0.15 \frac{\text{K} \cdot \text{ft}}{\text{ft}}$$

$$M_{\text{DCpar}} = \gamma_{\text{pDC}} \cdot W_{\text{par}} \cdot \left(1.4375 \text{ ft} - \frac{6.16 \text{ in}}{12 \frac{\text{in}}{\text{ft}}} \right)$$

$$M_{\text{DCpar}} = 0.61 \frac{\text{K} \cdot \text{ft}}{\text{ft}}$$

$$M_{\text{u total}} = M_{\text{co}} + M_{\text{DCdeck}} + M_{\text{DCpar}}$$

$$M_{\text{u total}} = 28.97 \frac{\text{K} \cdot \text{ft}}{\text{ft}}$$

SA13.4.1

S1.3.2.1

STable 3.4.1-2

The axial tensile force is:

$$T = \frac{R_w}{L_c + 2H_{par}}$$

Before the axial tensile force can be calculated, the terms L_c and R_w need to be defined.

L_c is the critical wall length over which the yield line mechanism occurs:

$$L_c = \frac{L_t}{2} + \sqrt{\left(\frac{L_t}{2}\right)^2 + \frac{8 \cdot H \cdot (M_b + M_w \cdot H)}{M_c}}$$

Since the parapet is not designed in this design example, the variables involved in this calculation are given below:

$L_t = 4 \text{ ft}$	longitudinal length of distribution of impact force F_t	SATable 13.2-1
$M_b = 0 \text{ K}\cdot\text{ft}^*$	additional flexural resistance of beam in addition to M_w , if any, at top of wall	
$M_c = 16.00 \frac{\text{K}\cdot\text{ft}}{\text{ft}}^*$	flexural resistance of the wall about an axis parallel to the longitudinal axis of the bridge	
$M_w = 18.52 \text{ K}\cdot\text{ft}^*$	flexural resistance of the wall about its vertical axis	
$H = 3.50 \text{ ft}$	height of parapet	

* Based on parapet properties not included in this design example. See Publication Number FHWA HI-95-017, Load and Resistance Factor Design for Highway Bridges, Participant Notebook, Volume II (Version 3.01), for the method used to compute the parapet properties.

L_c is then:

$$L_c = \frac{L_t}{2} + \sqrt{\left(\frac{L_t}{2}\right)^2 + \frac{8 \cdot H \cdot (M_b + M_w \cdot H)}{M_c}}$$

$$L_c = 12.84 \text{ ft}$$

R_w is the total transverse resistance of the railing and is calculated using the following equation for impacts within a wall segment: SA13.3.1

$$R_w = \left(\frac{2}{2 \cdot L_c - L_t} \right) \cdot \left(8 \cdot M_b + 8M_w \cdot H + \frac{M_c \cdot L_c^2}{H} \right)$$

$$R_w = 117.36 \text{ K}$$

$$\text{use } R_w = 117.40\text{K}$$

Now, the axial tensile force is: SA13.4.2

$$T = 5.92 \frac{\text{K}}{\text{ft}}$$

The overhang slab thickness is: $t_o = 9.0\text{in}$

For #5 bars: $\text{bar_diam} = 0.625\text{in}$

$$d_e = t_o - \text{Cover}_t - \frac{\text{bar_diam}}{2} \quad d_e = 6.19\text{in}$$

The required area of reinforcing steel is computed as follows:

$$b = 12\text{in}$$

$$R_n = \frac{M_{u\text{total}} \cdot 12\text{in}}{(\phi_{\text{ext}} \cdot b \cdot d_e^2)} \quad R_n = 0.76 \frac{\text{K}}{\text{in}^2}$$

$$\rho = 0.85 \left(\frac{f'_c}{f_y} \right) \cdot \left[1.0 - \sqrt{1.0 - \frac{(2 \cdot R_n)}{(0.85 \cdot f'_c)}} \right]$$

$$\rho = 0.0145$$

$$A_s = \rho \cdot \frac{b}{\text{ft}} \cdot d_e \quad A_s = 1.07 \frac{\text{in}^2}{\text{ft}}$$

$$\text{Use } A_s = 1.24 \frac{\text{in}^2}{\text{ft}} \quad (2 - \#5 \text{ bars bundled at } 6.0 \text{ in})$$

Once the required area of steel is known, the depth of the compression block must be checked:

$$T_a = A_s \cdot f_y \quad T_a = 74.40 \frac{\text{K}}{\text{ft}}$$

$$C = T_a - T \quad C = 68.48 \frac{\text{K}}{\text{ft}} \quad \text{Use} \quad C = 68.48\text{K}$$

$$a = \frac{C}{0.85 \cdot f'_c \cdot b} \quad a = 1.68 \text{ in}$$

$$M_n = T_a \cdot \left(d_e - \frac{a}{2} \right) - T \cdot \left(\frac{d_e}{2} - \frac{a}{2} \right) \quad M_n = 32.05 \frac{\text{K} \cdot \text{ft}}{\text{ft}}$$

$$M_r = \phi_{\text{ext}} \cdot M_n \quad M_r = 32.05 \frac{\text{K} \cdot \text{ft}}{\text{ft}}$$

$$M_r \geq M_{u_{\text{total}}} \quad \text{OK}$$

$$c = \frac{a}{\beta_1} \quad c = 1.97 \text{ in}$$

S5.7.2.2

$$\frac{c}{d_e} = 0.32 \quad \text{where} \quad \frac{c}{d_e} \leq 0.42$$

S5.7.3.3.1

$$0.32 \leq 0.42 \quad \text{OK}$$

Case 1B - Check at Design Section in Overhang

The collision forces are distributed over a distance L_c for moment and $L_c + 2H$ for axial force. When the design section is moved to $1/4b_f$ away from the girder centerline in the overhang, the distribution length will increase. This example assumes a distribution length increase based on a 30 degree angle from the face of the parapet.

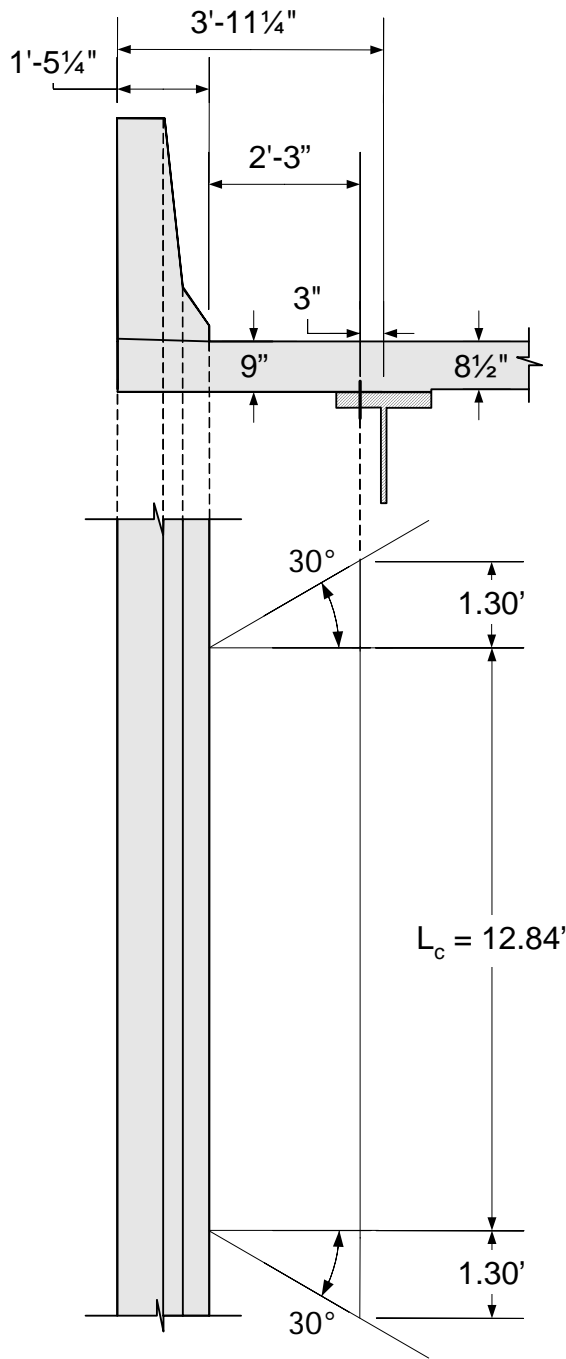

Figure 2-11 Assumed Distribution of Collision Moment Load in the Overhang

For the extreme event limit state:

$$\phi_{\text{ext}} = 1.0$$

$$\gamma_{\text{pDC}} = 1.25$$

$$\gamma_{\text{pDW}} = 1.50$$

$$L_c = 12.84\text{ft} \quad (\text{see parapet properties})$$

$$M_{\text{co}} = 28.21 \frac{\text{K}\cdot\text{ft}}{\text{ft}} \quad (\text{see parapet properties})$$

$$M_{\text{cB}} = \frac{M_{\text{co}} \cdot L_c}{L_c + 2 \cdot 1.30\text{ft}} \quad M_{\text{cB}} = 23.46 \frac{\text{K}\cdot\text{ft}}{\text{ft}}$$

Factored dead load moment:

$$M_{\text{DCdeck}} = \gamma_{\text{pDC}} \cdot \frac{\left[\left(\frac{9.0\text{in}}{12 \frac{\text{in}}{\text{ft}}} \right) \cdot (W_c) \cdot (3.6875\text{ft})^2 \right]}{2}$$

$$M_{\text{DCdeck}} = 0.96 \frac{\text{K}\cdot\text{ft}}{\text{ft}}$$

$$M_{\text{DCpar}} = \gamma_{\text{pDC}} \cdot W_{\text{par}} \cdot \left(3.6875\text{ft} - \frac{6.16\text{in}}{12 \frac{\text{in}}{\text{ft}}} \right)$$

$$M_{\text{DCpar}} = 2.10 \frac{\text{K}\cdot\text{ft}}{\text{ft}}$$

$$M_{\text{DWfws}} = \gamma_{\text{pDW}} \cdot \frac{\left[\left(\frac{2.5\text{in}}{12 \frac{\text{in}}{\text{ft}}} \right) \cdot (W_{\text{fws}}) \cdot (3.6875\text{ft} - 1.4375\text{ft})^2 \right]}{2}$$

$$M_{\text{DWfws}} = 0.11 \frac{\text{K}\cdot\text{ft}}{\text{ft}}$$

S1.3.2.1

STable 3.4.1-2

STable 3.4.1-2

$$M_{u\text{total}} = M_{cB} + M_{DC\text{deck}} + M_{DC\text{par}} + M_{DW\text{fws}}$$

$$M_{u\text{total}} = 26.63 \text{K} \cdot \frac{\text{ft}}{\text{ft}}$$

The axial tensile force is:

$$T = \frac{R_w}{L_c + 2H_{\text{par}} + 2 \cdot (1.30\text{ft})}$$

$$T = 5.23 \frac{\text{K}}{\text{ft}}$$

The overhang slab thickness is: $t_o = 9.0\text{in}$

For #5 bars: $\text{bar_diam} = 0.625\text{in}$

$$d_e = t_o - \text{Cover}_t - \frac{\text{bar_diam}}{2} \quad d_e = 6.19\text{in}$$

The required area of reinforcing steel is computed as follows:

$$b = 12\text{in}$$

$$R_n = \frac{M_{u\text{total}} \cdot 12\text{in}}{(\phi_{\text{ext}} \cdot b \cdot d_e^2)} \quad R_n = 0.70 \frac{\text{K}}{\text{in}^2}$$

$$\rho = 0.85 \left(\frac{f'_c}{f_y} \right) \left[1.0 - \sqrt{1.0 - \frac{(2 \cdot R_n)}{(0.85 \cdot f'_c)}} \right]$$

$$\rho = 0.0131$$

$$A_s = \rho \cdot \frac{b}{\text{ft}} \cdot d_e \quad A_s = 0.97 \frac{\text{in}^2}{\text{ft}}$$

The above required reinforcing steel is less than the reinforcing steel required for Case 1A.

SA13.4.2

Case 1C - Check at Design Section in First Span

The total collision moment can be treated as shown in Figure 2-12. The moment ratio, M_2/M_1 , can be calculated for the design strip. One way to approximate this moment is to set it equal to the ratio of the moments produced by the parapet self-weight at the 0.0S points of the first and second bay. The collision moment per unit width can then be determined by using the increased distribution length based on the 30 degree angle distribution (see Figure 2-11). The dead load moments at this section can be obtained directly from Table 2-1.

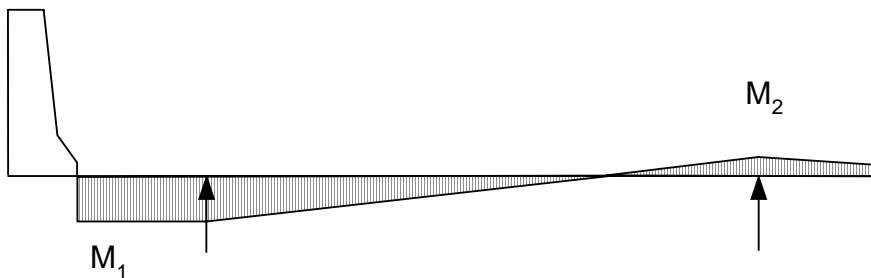

Figure 2-12 Assumed Distribution of the Collision Moment Across the Width of the Deck

Collision moment at exterior girder:

$$M_{co} = -28.21 \frac{\text{K}\cdot\text{ft}}{\text{ft}} \quad M_1 = M_{co}$$

Parapet self-weight moment at Girder 1 (0.0S in Bay 1):

$$\text{Par}_1 = -1.66 \frac{\text{K}\cdot\text{ft}}{\text{ft}}$$

Parapet self-weight moment at Girder 2 (0.0S in Bay 2):

$$\text{Par}_2 = 0.47 \frac{\text{K}\cdot\text{ft}}{\text{ft}}$$

Collision moment at $1/4b_f$ in Bay 1:

$$M_2 = M_1 \cdot \left(\frac{\text{Par}_2}{\text{Par}_1} \right) \quad M_2 = 7.99 \frac{\text{K}\cdot\text{ft}}{\text{ft}}$$

By interpolation for a design section at $1/4b_f$ in Bay 1, the total collision moment is:

$$M_{cM2M1} = M_{co} + 0.25ft \cdot \frac{(-M_{co} + M_2)}{9.75ft}$$

$$M_{cM2M1} = -27.28 \frac{K \cdot ft}{ft}$$

As in Case 1B, the 30 degree angle distribution will be used:

$$\phi_{ext} = 1.0$$

$$\gamma_{pDC} = 1.25$$

$$\gamma_{pDW} = 1.50$$

$$M_{cM2M1} = -27.28 \frac{K \cdot ft}{ft}$$

$$M_{cC} = \frac{M_{cM2M1} \cdot L_c}{L_c + 2 \cdot (1.59ft)} \quad M_{cC} = -21.87 \frac{K \cdot ft}{ft}$$

Factored dead load moment (from Table 2-1):

$$M_{DCdeck} = \gamma_{pDC} \cdot \left(-0.74 \frac{K \cdot ft}{ft} \right)$$

$$M_{DCdeck} = -0.93 K \cdot \frac{ft}{ft}$$

$$M_{DCpar} = \gamma_{pDC} \cdot \left(-1.66 \frac{K \cdot ft}{ft} \right)$$

$$M_{DCpar} = -2.08 \frac{K \cdot ft}{ft}$$

$$M_{DWfws} = \gamma_{pDW} \cdot \left(-0.06 \frac{K \cdot ft}{ft} \right)$$

$$M_{DWfws} = -0.09 \frac{K \cdot ft}{ft}$$

S1.3.2.1

STable 3.4.1-2

STable 3.4.1-2

$$M_{u_{total}} = M_{cC} + M_{DCdeck} + M_{DCpar} + M_{DWfws}$$

$$M_{u_{total}} = -24.96 \frac{\text{K}\cdot\text{ft}}{\text{ft}}$$

The axial tensile force is:

$$T = \frac{R_w}{L_c + 2H_{par} + 2 \cdot (1.59\text{ft})}$$

$$T = 5.10 \frac{\text{K}}{\text{ft}}$$

Use a slab thickness equal to: $t_s = 8.50\text{in}$

For #5 bars: $\text{bar_diam} = 0.625\text{in}$

$$d_e = t_s - \text{Cover}_t - \frac{\text{bar_diam}}{2} \quad d_e = 5.69\text{in}$$

The required area of reinforcing steel is computed as follows:

$$b = 12\text{in}$$

$$R_n = \frac{-M_{u_{total}} \cdot 12\text{in}}{(\phi_{ext} \cdot b \cdot d_e^2)} \quad R_n = 0.77 \frac{\text{K}}{\text{in}^2}$$

$$\rho = 0.85 \left(\frac{f'_c}{f_y} \right) \left[1.0 - \sqrt{1.0 - \frac{(2 \cdot R_n)}{(0.85 \cdot f'_c)}} \right]$$

$$\rho = 0.0148$$

$$A_s = \rho \cdot \frac{b}{\text{ft}} \cdot d_e \quad A_s = 1.01 \frac{\text{in}^2}{\text{ft}}$$

The above required reinforcing steel is less than the reinforcing steel required for Case 1A.

SA13.4.2

Design Case 2 - Design Overhang for Vertical Collision Force**SA13.4.1**

For concrete parapets, the case of vertical collision force never controls. Therefore, this procedure does not need to be considered in this design example.

Design Case 3 - Design Overhang for Dead Load and Live Load**SA13.4.1**Case 3A - Check at Design Section in Overhang

The resistance factor for the strength limit state for flexure and tension in concrete is:

S5.5.4.2.1

$$\phi_{str} = 0.90$$

The equivalent strip for live load on an overhang is:

STable 4.6.2.1.3-1

$$W_{overstrip} = 45.0 + 10.0 \cdot X^2$$

$$\text{For } X = 1.25 \text{ ft}$$

$$W_{overstrip} = 45.0 + 10.0X$$

$$W_{overstrip} = 57.50 \text{ in} \quad \text{or} \quad W_{overstrip} = 4.79\text{ft}$$

Use a multiple presence factor of 1.20 for one lane loaded.

STable 3.6.1.1.2-1

Use a dynamic load allowance of 0.33.

STable 3.6.2.1-1

Design factored overhang moment:

$$\gamma_{LL} = 1.75$$

STable 3.4.1-1

$$\gamma_{pDC} = 1.25$$

STable 3.4.1-2

$$\gamma_{pDW} = 1.50$$

STable 3.4.1-2

$$M_{DCdeck} = \gamma_{pDC} \cdot \frac{\left[\left(\frac{9.0\text{in}}{12 \frac{\text{in}}{\text{ft}}} \right) \cdot (W_c) \cdot (3.6875\text{ft})^2 \right]}{2}$$

$$M_{DCdeck} = 0.96 \frac{K \cdot ft}{ft}$$

$$M_{DCpar} = \gamma_{pDC} \cdot W_{par} \cdot \left(3.6875ft - \frac{6.16in}{12 \frac{in}{ft}} \right)$$

$$M_{DCpar} = 2.10 \frac{K \cdot ft}{ft}$$

$$M_{DWfws} = \gamma_{pDW} \cdot W_{fws} \cdot \frac{\left(\frac{2.5 \cdot in}{12 \cdot \frac{in}{ft}} \right) \cdot (3.6875 \cdot ft - 1.4375 \cdot ft)^2}{2}$$

$$M_{DWfws} = 0.11 \frac{K \cdot ft}{ft}$$

$$M_{LL} = \gamma_{LL} \cdot (1 + IM) \cdot (1.20) \cdot \left(\frac{16K}{W_{overstrip}} \right) \cdot 1.25ft$$

$$M_{LL} = 11.66 \frac{K \cdot ft}{ft}$$

$$M_{Utotal} = M_{DCdeck} + M_{DCpar} + M_{DWfws} + M_{LL}$$

$$M_{Utotal} = 14.83 \frac{K \cdot ft}{ft}$$

Calculate the required area of steel:

For #5 bars: $\text{bar_diam} = 0.625in$

$$d_e = t_o - \text{Cover}_t - \frac{\text{bar_diam}}{2}$$

$$d_e = 6.19in$$

$$b = 12in$$

$$R_n = \frac{M_{Utotal} \cdot 12in}{\left(\phi_{str} \cdot b \cdot d_e^2 \right)} \quad R_n = 0.43 \frac{K}{in^2}$$

$$\rho = 0.85 \left(\frac{f'_c}{f_y} \right) \left[1.0 - \sqrt{1.0 - \frac{(2 \cdot R_n)}{(0.85 \cdot f'_c)}} \right]$$

$$\rho = 0.00770$$

$$A_s = \rho \cdot \frac{b}{ft} \cdot d_e \qquad A_s = 0.57 \frac{\text{in}^2}{ft}$$

The above required reinforcing steel is less than the reinforcing steel required for Cases 1A, 1B, and 1C.

Case 3B - Check at Design Section in First Span

Use a slab thickness equal to: $t_s = 8.50 \text{ in}$

The dead and live load moments are taken from Tables 2-1 and 2-2. The maximum negative live load moment occurs in Bay 4. Since the negative live load moment is produced by a load on the overhang, compute the equivalent strip based on a moment arm to the centerline of girder.

Design factored moment:

$$\gamma_{LL} = 1.75$$

$$\gamma_{pDC} = 1.25$$

$$\gamma_{pDW} = 1.50$$

$$W_{\text{overstrip}} = 45.0 + 10.0 \cdot X^2$$

$$\text{For } X = 1.50 \text{ ft}$$

$$W_{\text{overstrip}} = 45.0 + 10.0X$$

$$W_{\text{overstrip}} = 60.00 \text{ in} \quad \text{or} \quad W_{\text{overstrip}} = 5.00 \text{ ft}$$

STable 3.4.1-1

STable 3.4.1-2

STable 3.4.1-2

$$M_{DCdeck} = \gamma_{pDC} \cdot \left(-0.74 \frac{K \cdot ft}{ft} \right)$$

$$M_{DCdeck} = -0.93 \frac{K \cdot ft}{ft}$$

$$M_{DCpar} = \gamma_{pDC} \cdot \left(-1.66 \frac{K \cdot ft}{ft} \right)$$

$$M_{DCpar} = -2.08 \frac{K \cdot ft}{ft}$$

$$M_{DWfws} = \gamma_{pDW} \cdot \left(-0.06 \frac{K \cdot ft}{ft} \right)$$

$$M_{DWfws} = -0.09 \frac{K \cdot ft}{ft}$$

$$M_{LL} = \gamma_{LL} \cdot (1 + IM) \cdot \frac{(-29.40 K \cdot ft)}{W_{overstrip}}$$

$$M_{LL} = -13.69 \frac{K \cdot ft}{ft}$$

$$M_{u_{total}} = M_{DCdeck} + M_{DCpar} + M_{DWfws} + M_{LL}$$

$$M_{u_{total}} = -16.78 \frac{K \cdot ft}{ft}$$

Calculate the required area of steel:

For #5 bars: $bar_diam = 0.625in$

$$d_e = t_s - Cover_t - \frac{bar_diam}{2}$$

$$d_e = 5.69in$$

$$b = 12in$$

$$R_n = \frac{-M_{u\text{total}} \cdot 12\text{in}}{(\phi_{\text{str}} \cdot b \cdot d_e^2)} \quad R_n = 0.58 \frac{\text{K}}{\text{in}^2}$$

$$\rho = 0.85 \left(\frac{f'_c}{f_y} \right) \left[1.0 - \sqrt{1.0 - \frac{(2 \cdot R_n)}{(0.85 \cdot f'_c)}} \right]$$

$$\rho = 0.0106$$

$$A_s = \rho \cdot \frac{b}{\text{ft}} \cdot d_e \quad A_s = 0.72 \frac{\text{in}^2}{\text{ft}}$$

The above required reinforcing steel is less than the reinforcing steel required for Cases 1A, 1B, and 1C.

The required area of reinforcing steel in the overhang is the largest of that required for Cases 1A, 1B, 1C, 3A, and 3B.

Case 1A controls with: $A_s = 1.24 \frac{\text{in}^2}{\text{ft}}$

The negative flexure reinforcement provided from the design in Steps 2.10 and 2.11 is:

#5 bars at 6.0 inches: $\text{bar_diam} = 0.625\text{in}$
 $\text{bar_area} = 0.31\text{in}^2$

$$A_{\text{sneg}} = \frac{\text{bar_area}}{\text{ft}} \cdot \left(\frac{12\text{in}}{6\text{in}} \right)$$

$$A_{\text{sneg}} = 0.62 \frac{\text{in}^2}{\text{ft}}$$

$$0.62 \frac{\text{in}^2}{\text{ft}} < 1.24 \frac{\text{in}^2}{\text{ft}}$$

Since the area of reinforcing steel required in the overhang is greater than the area of reinforcing steel required in the negative moment regions, reinforcement must be added in the overhang area to satisfy the design requirements.

Bundle one #5 bar to each negative flexure reinforcing bar in the overhang area.

The new area of reinforcing steel is now: $A_s = 2 \cdot \left(0.31 \cdot \frac{\text{in}^2}{\text{ft}} \right) \cdot \left(\frac{12\text{in}}{6\text{in}} \right)$

$$A_s = 1.24 \frac{\text{in}^2}{\text{ft}}$$

Once the required area of reinforcing steel is known, the depth of the compression block must be checked. The ratio of c/d_e is more critical at the minimum deck thickness, so c/d_e will be checked in Bay 1 where the deck thickness is 8.5 inches.

$$d_{\text{emin}} = t_s - \text{Cover}_t - \frac{\text{bar_diam}}{2}$$

$$d_{\text{emin}} = 5.69\text{in}$$

$$T = A_s \cdot f_y \quad T = 74.40 \frac{\text{K}}{\text{ft}} \quad \text{Use} \quad T = 74.40\text{K}$$

$$a = \frac{T}{0.85 \cdot f'_c \cdot b} \quad a = 1.82\text{in}$$

$$c = \frac{a}{\beta_1} \quad c = 2.15\text{in}$$

S5.7.2.2

$$\frac{c}{d_{\text{emin}}} = 0.38 \quad \text{where} \quad \frac{c}{d_e} \leq 0.42$$

S5.7.3.3.1

$$0.38 \leq 0.42 \quad \text{OK}$$

Design Step 2.13 - Check for Cracking in Overhang under Service Limit State

Cracking in the overhang must be checked for the controlling service load (similar to Design Steps 2.9 and 2.11). In most deck overhang design cases, cracking does not control. Therefore, the computations for the cracking check are not shown in this deck overhang design example.

Design Step 2.14 - Compute Overhang Cut-off Length Requirement

The next step is to compute the cut-off location of the additional #5 bars in the first bay. This is done by determining the location where both the dead and live load moments, as well as the dead and collision load moments, are less than or equal to the resistance provided by #5 bars at 6 inch spacing (negative flexure steel design reinforcement).

Compute the nominal negative moment resistance based on #5 bars at 6 inch spacing:

$$\text{bar_diam} = 0.625\text{in}$$

$$\text{bar_area} = 0.31\text{in}^2$$

$$A_s = \frac{\text{bar_area}}{\text{ft}} \cdot \left(\frac{12\text{in}}{6\text{in}} \right)$$

$$A_s = 0.62 \frac{\text{in}^2}{\text{ft}}$$

$$d_e = t_s - \text{Cover}_t - \frac{\text{bar_diam}}{2}$$

$$d_e = 5.69\text{in}$$

$$T = A_s \cdot f_y \quad T = 37.20 \frac{\text{K}}{\text{ft}} \quad \text{Use} \quad T = 37.20\text{K}$$

$$a = \frac{T}{0.85 \cdot f_c \cdot b} \quad a = 0.91\text{in}$$

$$M_n = A_s \cdot f_y \cdot \left(d_e - \frac{a}{2} \right)$$

$$M_n = 16.22 \frac{\text{K} \cdot \text{ft}}{\text{ft}}$$

Compute the nominal flexural resistance for negative flexure, as follows:

$$M_r = \phi_f \cdot M_n$$

$$M_r = 14.60 \frac{\text{K} \cdot \text{ft}}{\text{ft}}$$

Based on the nominal flexural resistance and on interpolation of the factored design moments, the theoretical cut-off point for the additional #5 bar is 3.75 feet from the centerline of the fascia girder.

The additional cut-off length (or the distance the reinforcement must extend beyond the theoretical cut-off point) is the maximum of:

S5.11.1.2

The effective depth of the member: $d_e = 5.69 \text{ in}$

15 times the nominal bar diameter: $15 \cdot 0.625 \text{ in} = 9.38 \text{ in}$

1/20 of the clear span: $\frac{1}{20} \cdot \left(9.75 \text{ ft} \cdot 12 \frac{\text{in}}{\text{ft}} \right) = 5.85 \text{ in}$

Use $\text{cut_off} = 9.5 \text{ in}$

The total required length past the centerline of the fascia girder into the first bay is:

$$\text{cut_off}_{\text{total}} = 3.75 \text{ ft} \cdot 12 \frac{\text{in}}{\text{ft}} + \text{cut_off}$$

$$\text{cut_off}_{\text{total}} = 54.50 \text{ in}$$

Design Step 2.15 - Compute Overhang Development Length

$$d_b = 0.625 \text{ in}$$

$$A_b = 0.31 \text{ in}^2$$

$$f'_c = 4.0 \text{ ksi}$$

$$f_y = 60 \text{ ksi}$$

The basic development length is the larger of the following:

S5.11.2.1.1

$$\frac{1.25 \cdot A_b \cdot f_y}{\sqrt{f'_c}} = 11.63 \text{ in} \quad \text{or} \quad 0.4 \cdot d_b \cdot f_y = 15.00 \text{ in} \quad \text{or} \quad 12 \text{ in}$$

Use $l_d = 15.00 \text{ in}$

The following modification factors must be applied:

S5.11.2

Epoxy coated bars: 1.2

S5.11.2.1.2

Bundled bars: 1.2

S5.11.2.3

Spacing > 6 inches with more than 3 inches of clear cover in direction of spacing: 0.8

S5.11.2.1.3

$$l_d = 15.00\text{in} \cdot (1.2) \cdot (1.2) \cdot (0.8)$$

$$l_d = 17.28\text{in} \quad \text{Use} \quad l_d = 18.00\text{in}$$

The required length past the centerline of the fascia girder is:

$$3.0\text{in} + l_d = 21.00\text{in}$$

$$21.00\text{in} < 54.50\text{in} \quad \text{provided}$$

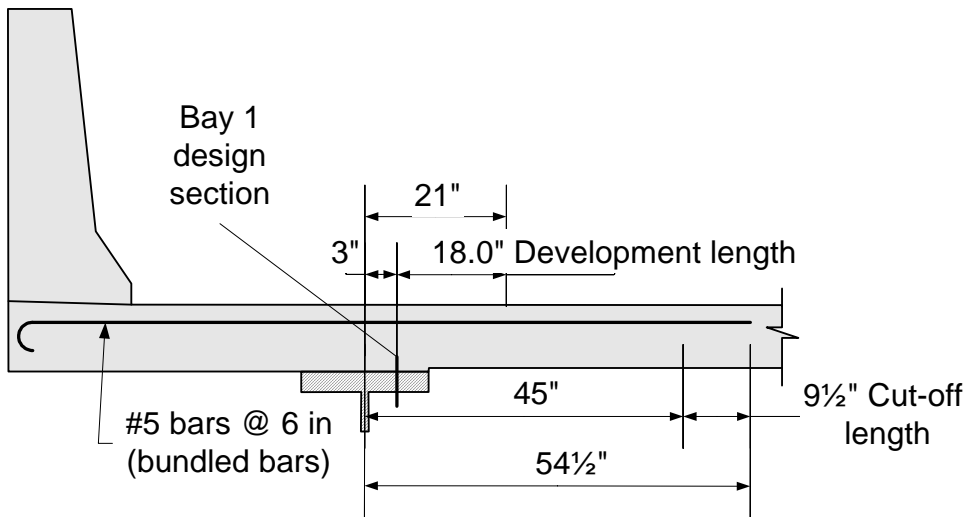

Figure 2-13 Length of Overhang Negative Moment Reinforcement

Design Step 2.16 - Design Bottom Longitudinal Distribution Reinforcement

The bottom longitudinal distribution reinforcement is calculated based on whether the primary reinforcement is parallel or perpendicular to traffic.

S9.7.3.2

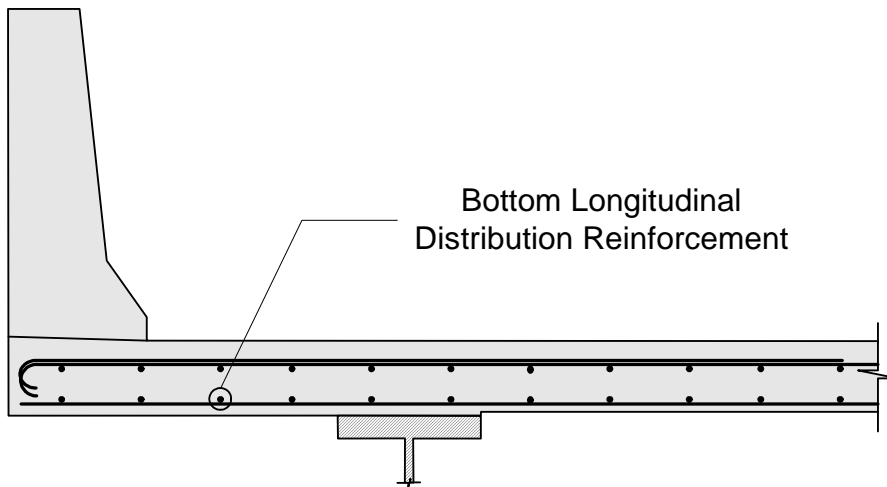

Figure 2-14 Bottom Longitudinal Distribution Reinforcement

For this design example, the primary reinforcement is perpendicular to traffic.

$$S_e = 9.25 \text{ ft}$$

$$A_{sbotpercent} = \frac{220}{\sqrt{S_e}} \quad \text{where} \quad A_{sbotlong} \leq 67\%$$

$$A_{sbotpercent} = 72.3 \quad \%$$

$$\text{Use} \quad A_{sbotpercent} = 67\%$$

For this design example, #5 bars at 8 inches were used to resist the primary positive moment.

$$\text{bar_diam} = 0.625 \text{ in}$$

$$\text{bar_area} = 0.31 \text{ in}^2$$

$$A_{s_ft} = \text{bar_area} \cdot \left(\frac{12 \text{ in}}{8 \text{ in}} \right)$$

$$A_{s_ft} = 0.465 \frac{\text{in}^2}{\text{ft}}$$

$$A_{sbotlong} = A_{sbotpercent} \cdot A_{s_ft}$$

$$A_{sbotlong} = 0.31 \frac{\text{in}^2}{\text{ft}}$$

Calculate the required spacing using #5 bars:

$$\text{spacing} = \frac{\text{bar_area}}{A_{sbotlong}}$$

$$\text{spacing} = 1.00\text{ft} \quad \text{or} \quad \text{spacing} = 11.94\text{in}$$

Use spacing = 10in

Use #5 bars at 10 inch spacing for the bottom longitudinal reinforcement.

Design Step 2.17 - Design Top Longitudinal Distribution Reinforcement

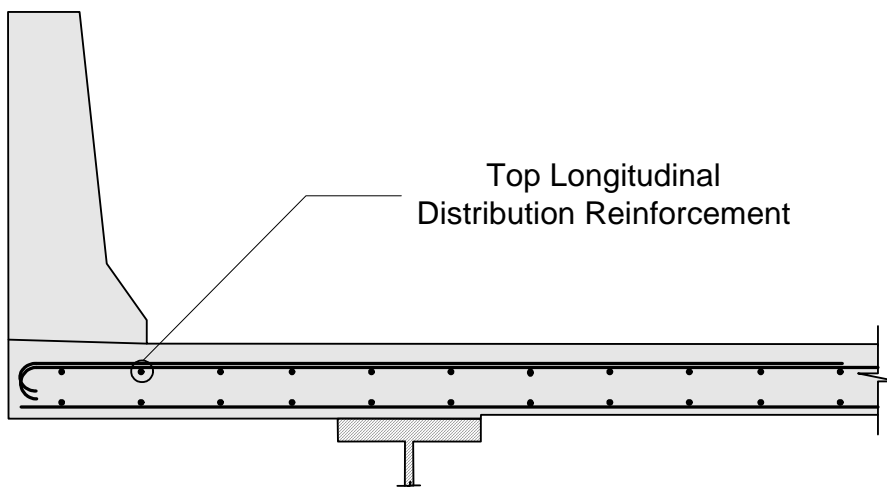

Figure 2-15 Top Longitudinal Distribution Reinforcement

The top longitudinal temperature and shrinkage reinforcement must satisfy:

S5.10.8.2

$$A_s \geq 0.11 \frac{A_g}{f_y}$$

$$A_g = 8.5 \text{ in} \cdot \left(12.0 \frac{\text{in}}{\text{ft}} \right) \quad A_g = 102.00 \frac{\text{in}^2}{\text{ft}}$$

$$0.11 \frac{A_g}{f_y} = 0.19 \frac{\text{in}^2}{\text{ft}}$$

When using the above equation, the calculated area of reinforcing steel must be equally distributed on both concrete faces. In addition, the maximum spacing of the temperature and shrinkage reinforcement must be the smaller of 3.0 times the deck thickness or 18.0 inches.

The amount of steel required for the top longitudinal reinforcement is:

$$A_{s\text{req}} = \frac{0.19 \cdot \frac{\text{in}^2}{\text{ft}}}{2} \quad A_{s\text{req}} = 0.10 \frac{\text{in}^2}{\text{ft}}$$

Check #4 bars at 10 inch spacing:

$$A_{\text{sact}} = 0.20 \cdot \frac{\text{in}^2}{\text{ft}} \cdot \left(\frac{12 \text{ in}}{10 \text{ in}} \right) \quad A_{\text{sact}} = 0.24 \frac{\text{in}^2}{\text{ft}}$$

$$0.24 \frac{\text{in}^2}{\text{ft}} > 0.10 \frac{\text{in}^2}{\text{ft}} \quad \text{OK}$$

Use #4 bars at 10 inch spacing for the top longitudinal temperature and shrinkage reinforcement.

Design Step 2.18 - Design Longitudinal Reinforcement over Piers

If the superstructure is comprised of simple span precast girders made continuous for live load, the top longitudinal reinforcement should be designed according to S5.14.1.2.7. For continuous steel girder superstructures, design the top longitudinal reinforcement according to S6.10.3.7. For this design example, continuous steel girders are used.

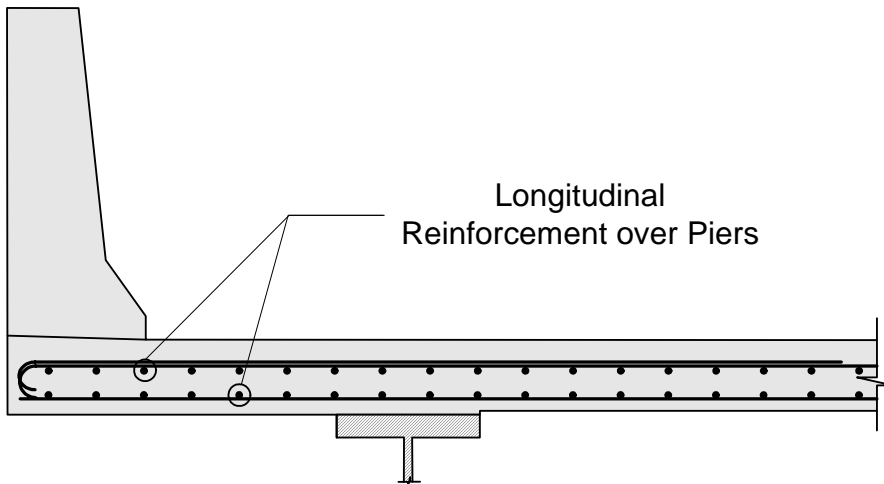

Figure 2-16 Longitudinal Reinforcement over Piers

The total longitudinal reinforcement should not be less than 1 percent of the total slab cross-sectional area. These bars must have a specified minimum yield strength of at least 60 ksi. Also, the bar size cannot be larger than a #6 bar.

S6.10.3.7

Deck cross section:

$$A_{\text{deck}} = \frac{8.5\text{in} \cdot 12\text{in}}{\text{ft}}$$

$$A_{\text{deck}} = 102.00 \frac{\text{in}^2}{\text{ft}}$$

$$A_{s_1_percent} = 0.01 \cdot A_{\text{deck}}$$

$$A_{s_1_percent} = 1.02 \frac{\text{in}^2}{\text{ft}}$$

Two-thirds of the required longitudinal reinforcement should be placed uniformly in the top layer of the deck, and the remaining portion should be placed uniformly in the bottom layer. For both rows, the spacing should not exceed 6 inches.

S6.10.3.7

$$\left(\frac{2}{3}\right) \cdot A_{s_1_percent} = 0.68 \frac{\text{in}^2}{\text{ft}} \quad \left(\frac{1}{3}\right) \cdot A_{s_1_percent} = 0.34 \frac{\text{in}^2}{\text{ft}}$$

Use #5 bars at 5 inch spacing in the top layer.

$$A_{s\text{provided}} = 0.31 \frac{\text{in}^2}{\text{ft}} \cdot \left(\frac{12\text{in}}{5\text{in}}\right)$$

$$A_{s\text{provided}} = 0.74 \frac{\text{in}^2}{\text{ft}} > 0.68 \frac{\text{in}^2}{\text{ft}} \quad \text{OK}$$

Use #5 bars at 5 inch spacing in the bottom layer to satisfy the maximum spacing requirement of 6 inches.

$$A_{s\text{provided}} = 0.31 \frac{\text{in}^2}{\text{ft}} \cdot \left(\frac{12\text{in}}{5\text{in}}\right)$$

$$A_{s\text{provided}} = 0.74 \frac{\text{in}^2}{\text{ft}} > 0.34 \frac{\text{in}^2}{\text{ft}} \quad \text{OK}$$

Design Step 2.19 - Draw Schematic of Final Concrete Deck Design

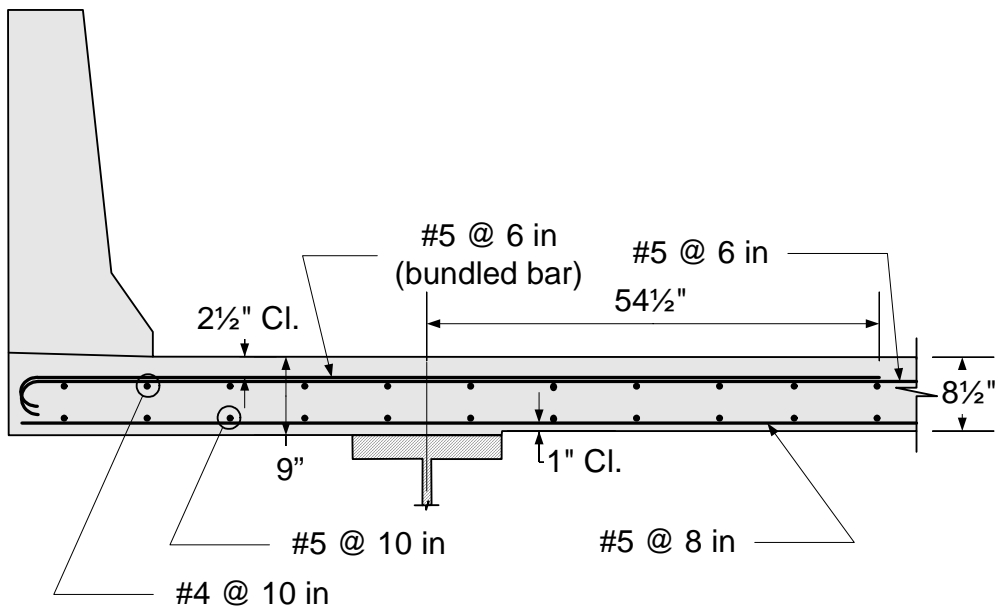

Figure 2-17 Superstructure Positive Moment Deck Reinforcement

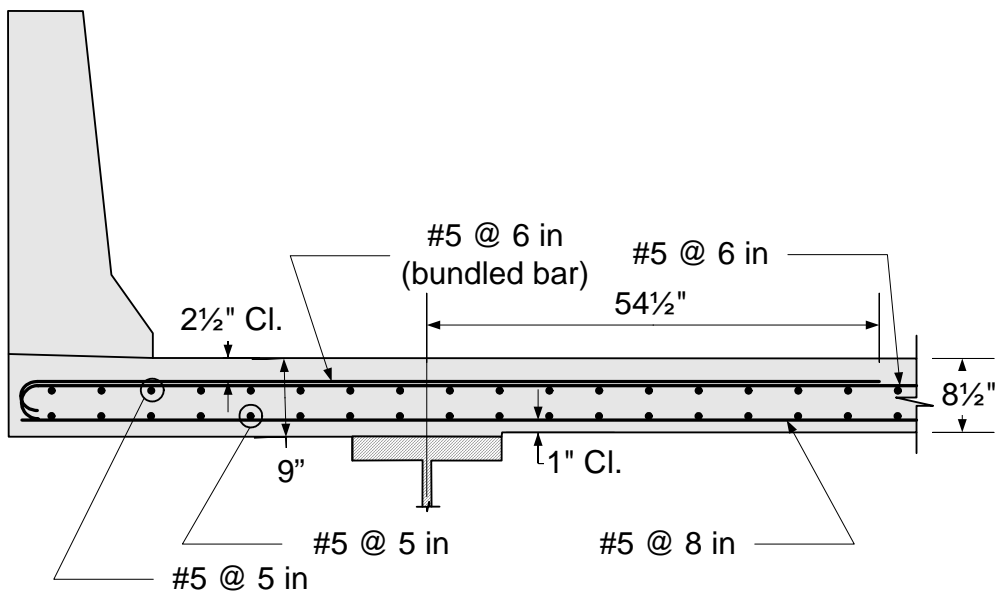

Figure 2-18 Superstructure Negative Moment Deck Reinforcement

Steel Girder Design Example Design Step 3

Table of Contents

	<u>Page</u>
Design Step 3.1 - Obtain Design Criteria	2
Design Step 3.2 - Select Trial Girder Section	8
Design Step 3.3 - Compute Section Properties	10
Design Step 3.4 - Compute Dead Load Effects	14
Design Step 3.5 - Compute Live Load Effects	20
Design Step 3.6 - Combine Load Effects	27
Positive Moment Region:	
Design Step 3.7 - Check Section Proportion Limits	35
Design Step 3.8 - Compute Plastic Moment Capacity	37
Design Step 3.9 - Determine if Section is Compact or Noncompact	39
Design Step 3.10 - Design for Flexure - Strength Limit State	40
Design Step 3.11 - Design for Shear	44
Design Step 3.12 - Design Transverse Intermediate Stiffeners	44
Design Step 3.14 - Design for Flexure - Fatigue and Fracture	44
Design Step 3.15 - Design for Flexure - Service Limit State	47
Design Step 3.16 - Design for Flexure - Constructibility Check	48
Design Step 3.17 - Check Wind Effects on Girder Flanges	56
Negative Moment Region:	
Design Step 3.7 - Check Section Proportion Limits	57
Design Step 3.8 - Compute Plastic Moment Capacity	60
Design Step 3.9 - Determine if Section is Compact or Noncompact	61
Design Step 3.10 - Design for Flexure - Strength Limit State	63
Design Step 3.11 - Design for Shear	67
Design Step 3.12 - Design Transverse Intermediate Stiffeners	72
Design Step 3.14 - Design for Flexure - Fatigue and Fracture	76
Design Step 3.15 - Design for Flexure - Service Limit State	78
Design Step 3.16 - Design for Flexure - Constructibility Check	81
Design Step 3.17 - Check Wind Effects on Girder Flanges	83
Design Step 3.18 - Draw Schematic of Final Steel Girder Design	87

Design Step 3.1 - Obtain Design Criteria

The first design step for a steel girder is to choose the correct design criteria.

The steel girder design criteria are obtained from Figures 3-1 through 3-3 (shown below), from the concrete deck design example, and from the referenced articles and tables in the *AASHTO LRFD Bridge Design Specifications* (through 2002 interims). For this steel girder design example, a plate girder will be designed for an HL-93 live load. The girder is assumed to be composite throughout.

Refer to Design Step 1 for introductory information about this design example. Additional information is presented about the design assumptions, methodology, and criteria for the entire bridge, including the steel girder.

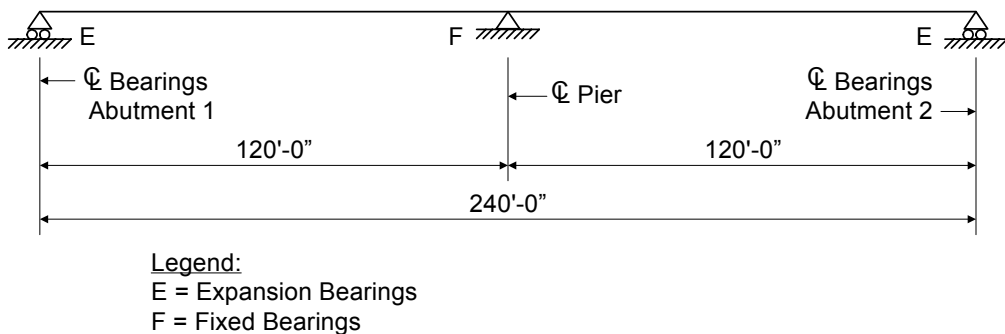

Figure 3-1 Span Configuration

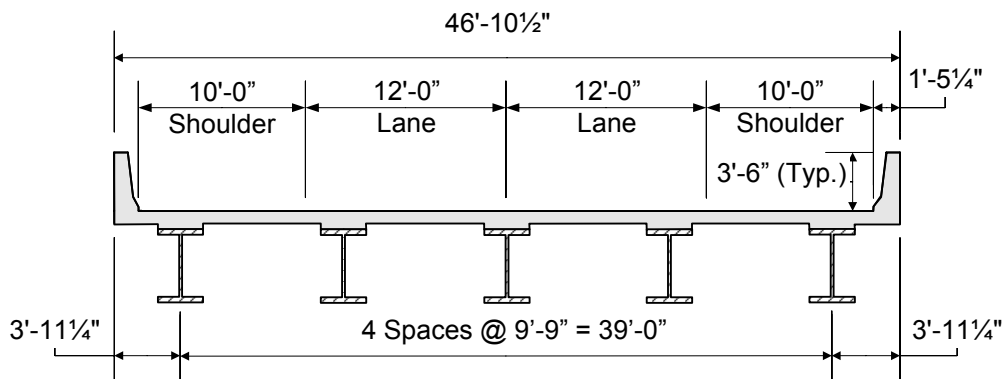



Figure 3-2 Superstructure Cross Section



Girder Spacing

Where depth or deflection limitations do not control the design, it is generally more cost-effective to use a wider girder spacing. For this design example, the girder spacing shown in Figure 3-2 was developed as a reasonable value for all limit states. Four girders are generally considered to be the minimum, and five girders are desirable to facilitate future redecking. Further optimization of the superstructure could be achieved by revising the girder spacing.



Overhang Width

The overhang width is generally determined such that the moments and shears in the exterior girder are similar to those in the interior girder. In addition, the overhang is set such that the positive and negative moments in the deck slab are balanced. A common rule of thumb is to make the overhang approximately 0.35 to 0.5 times the girder spacing.

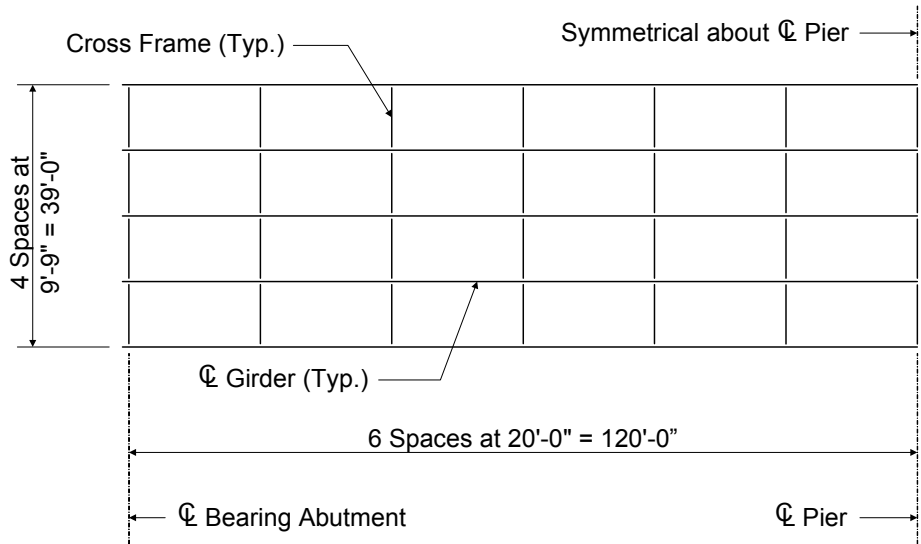

Figure 3-3 Framing Plan



Cross-frame Spacing

A common rule of thumb, based on previous editions of the AASHTO Specifications, is to use a maximum cross-frame spacing of 25 feet.

For this design example, a cross-frame spacing of 20 feet is used because it facilitates a reduction in the required flange thicknesses in the girder section at the pier.

This spacing also affects constructibility checks for stability before the deck is cured. Currently, stay-in-place forms should not be considered to provide adequate bracing to the top flange.

The following units are defined for use in this design example:

$$K = 1000\text{lb} \quad \text{kcf} = \frac{K}{\text{ft}^3} \quad \text{ksf} = \frac{K}{\text{ft}^2} \quad \text{ksi} = \frac{K}{\text{in}^2}$$

Design criteria:

Number of spans: $N_{\text{spans}} = 2$

Span length: $L_{\text{span}} = 120\text{ft}$

Skew angle: $\text{Skew} = 0\text{deg}$

Number of girders: $N_{\text{girders}} = 5$

Girder spacing: $S = 9.75\text{ft}$

Deck overhang: $S_{\text{overhang}} = 3.9375\text{ft}$

Cross-frame spacing: $L_b = 20\text{ft}$

Web yield strength: $F_{yw} = 50\text{ksi}$

Flange yield strength: $F_{yf} = 50\text{ksi}$

Concrete 28-day compressive strength: $f_c = 4.0\text{ksi}$

Reinforcement strength: $f_y = 60\text{ksi}$

S6.7.4

S6.4.1-1

S6.4.1-1

S5.4.2.1 &
S5.4.2.1-1

S5.4.3 & S6.10.3.7

Design criteria (continued):

Total deck thickness: $t_{\text{deck}} = 8.5\text{in}$

Effective deck thickness: $t_{\text{effdeck}} = 8.0\text{in}$

Total overhang thickness: $t_{\text{overhang}} = 9.0\text{in}$

Effective overhang thickness: $t_{\text{effoverhang}} = 8.5\text{in}$

Steel density: $W_s = 0.490\text{kcf}$

STable 3.5.1-1

Concrete density: $W_c = 0.150\text{kcf}$

STable 3.5.1-1

Additional miscellaneous dead load (per girder): $W_{\text{misc}} = 0.015 \frac{\text{K}}{\text{ft}}$

Stay-in-place deck form weight: $W_{\text{deckforms}} = 0.015\text{kcf}$

Parapet weight (each): $W_{\text{par}} = 0.53 \frac{\text{K}}{\text{ft}}$

Future wearing surface: $W_{\text{fws}} = 0.140\text{kcf}$

STable 3.5.1-1

Future wearing surface thickness: $t_{\text{fws}} = 2.5\text{in}$

Deck width: $W_{\text{deck}} = 46.875\text{ft}$

Roadway width: $W_{\text{roadway}} = 44.0\text{ft}$

Haunch depth (from top of web): $d_{\text{haunch}} = 3.5\text{in}$

Average Daily Truck Traffic (Single-Lane): $ADTT_{\text{SL}} = 3000$

For this design example, transverse stiffeners will be designed in Step 3.12. In addition, a bolted field splice will be designed in Step 4, shear connectors will be designed in Step 5.1, bearing stiffeners will be designed in Step 5.2, welded connections will be designed in Step 5.3, cross-frames are described in Step 5.4, and an elastomeric bearing will be designed in Step 6. Longitudinal stiffeners will not be used, and a deck pouring sequence will not be considered in this design example.

Design factors from AASHTO LRFD Bridge Design Specifications:

Load factors:

Load Combinations and Load Factors							
Limit State	Load Factors						
	DC	DW	LL	IM	WS	WL	EQ
Strength I	1.25	1.50	1.75	1.75	-	-	-
Service II	1.00	1.00	1.30	1.30	-	-	-
Fatigue	-	-	0.75	0.75	-	-	-

Table 3-1 Load Combinations and Load Factors

The abbreviations used in Table 3-1 are as defined in S3.3.2.

The extreme event limit state (including earthquake load) is generally not considered for a steel girder design.

Resistance factors:

Resistance Factors	
Type of Resistance	Resistance Factor, ϕ
For flexure	$\phi_f = 1.00$
For shear	$\phi_v = 1.00$
For axial compression	$\phi_c = 0.90$

Table 3-2 Resistance Factors

S6.5.4.2
 STable 3.4.1-1 &
 STable 3.4.1-2

S6.5.4.2

Multiple Presence Factors



Multiple presence factors are described in S3.6.1.1.2. They are already included in the computation of live load distribution factors, as presented in S4.6.2.2. An exception, however, is that they must be included when the live load distribution factor for an exterior girder is computed assuming that the cross section deflects and rotates as a rigid cross section, as presented in S4.6.2.2.2d.

Since S3.6.1.1.2 states that the effects of the multiple presence factor are not to be applied to the fatigue limit state, all empirically determined distribution factors for one-lane loaded that are applied to the single fatigue truck must be divided by 1.20 (that is, the multiple presence factor for one lane loaded). In addition, for distribution factors computed using the lever rule or based on S4.6.2.2.2d, the 1.20 factor should not be included when computing the distribution factor for one-lane loaded for the fatigue limit state. It should also be noted that the multiple presence factor still applies to the distribution factors for one-lane loaded for strength limit states.

Dynamic load allowance:

STable 3.6.2.1-1

Dynamic Load Allowance	
Limit State	Dynamic Load Allowance, IM
Fatigue and Fracture Limit State	15%
All Other Limit States	33%

Table 3-3 Dynamic Load Allowance

Dynamic load allowance is the same as impact. The term "impact" was used in previous editions of the AASHTO Specifications. However, the term "dynamic load allowance" is used in the *AASHTO LRFD Bridge Design Specifications*.

Design Step 3.2 - Select Trial Girder Section

Before the dead load effects can be computed, a trial girder section must be selected. This trial girder section is selected based on previous experience and based on preliminary design. For this design example, the trial girder section presented in Figure 3-4 will be used. Based on this trial girder section, section properties and dead load effects will be computed. Then specification checks will be performed to determine if the trial girder section successfully resists the applied loads. If the trial girder section does not pass all specification checks or if the girder optimization is not acceptable, then a new trial girder section must be selected and the design process must be repeated.

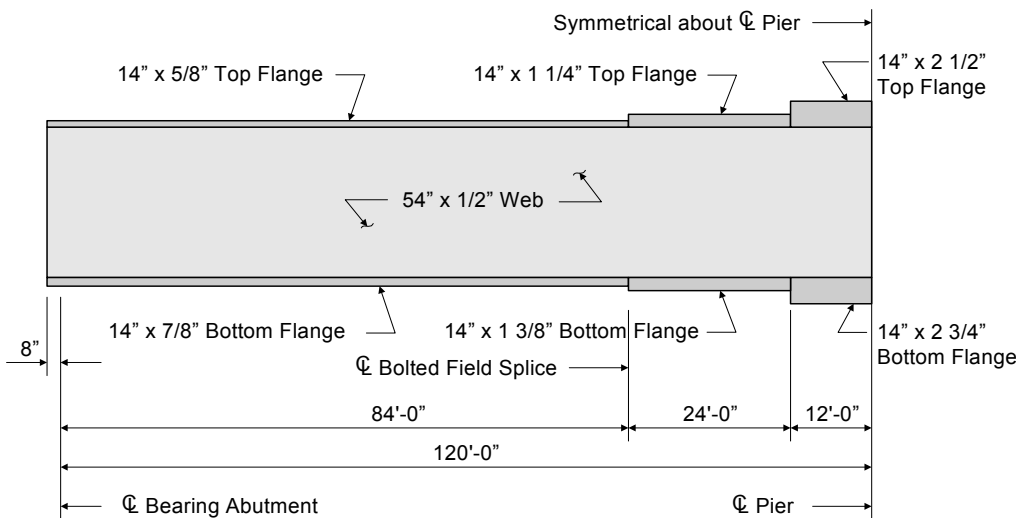

Figure 3-4 Plate Girder Elevation

For this design example, the 5/8" top flange thickness in the positive moment region was used to optimize the plate girder. It also satisfies the requirements of S6.7.3. However, it should be noted that some state requirements and some fabricator concerns may call for a 3/4" minimum flange thickness. In addition, the AASHTO/NSBA Steel Bridge Collaboration Document "Guidelines for Design for Constructibility" recommends a 3/4" minimum flange thickness.



Girder Depth

The minimum girder depth is specified in *S*Table 2.5.2.6.3-1. An estimate of the optimum girder depth can be obtained from trial runs using readily available design software. The web depth may be varied by several inches more or less than the optimum without significant cost penalty.

**Web Thickness**

A "nominally stiffened" web (approximately 1/16 inch thinner than "unstiffened") will generally provide the least cost alternative or very close to it. However, for web depths of approximately 50 inches or less, unstiffened webs may be more economical.

**Plate Transitions**

A common rule of thumb is to use no more than three plates (two shop splices) in the top or bottom flange of field sections up to 130 feet long. In some cases, a single flange plate size can be carried through the full length of the field section.

**Flange Widths**

Flange widths should remain constant within field sections. The use of constant flange widths simplifies construction of the deck. The unsupported length in compression of the shipping piece divided by the minimum width of the compression flange in that piece should be less than approximately 85.

**Flange Plate Transitions**

It is good design practice to reduce the flange cross-sectional area by no more than approximately one-half of the area of the heavier flange plate. This reduces the build-up of stress at the transition.

The above tips are presented to help bridge designers in developing an economical steel girder for most steel girder designs. Other design tips are available in various publications from the American Institute of Steel Construction (AISC) and from steel fabricators.

Design Step 3.3 - Compute Section Properties

Since the superstructure is composite, several sets of section properties must be computed. The initial dead loads (or the noncomposite dead loads) are applied to the girder-only section. The superimposed dead loads are applied to the composite section based on a modular ratio of $3n$ or n , whichever gives the higher stresses.

S6.10.3.1

S6.10.3.1.1b



Modular Ratio

As specified in S6.10.3.1.1b, for permanent loads assumed to be applied to the long-term composite section, the slab area shall be transformed by using a modular ratio of $3n$ or n , whichever gives the higher stresses.

Using a modular ratio of $3n$ for the superimposed dead loads always gives higher stresses in the steel section. Using a modular ratio of n typically gives higher stresses in the concrete deck, except in the moment reversal regions where the selection of $3n$ vs. n can become an issue in determining the maximum stress in the deck.

The live loads are applied to the composite section based on a modular ratio of n .

For girders with shear connectors provided throughout their entire length and with slab reinforcement satisfying the provisions of S6.10.3.7, stresses due to loads applied to the composite section for service and fatigue limit states may be computed using the composite section assuming the concrete slab to be fully effective for both positive and negative flexure.

S6.6.1.2.1 &
S6.10.5.1

Therefore, for this design example, the concrete slab will be assumed to be fully effective for both positive and negative flexure for service and fatigue limit states.

For this design example, the interior girder controls. In general, both the exterior and interior girders must be considered, and the controlling design is used for all girders, both interior and exterior.

For this design example, only the interior girder design is presented. However, for the exterior girder, the computation of the live load distribution factors and the moment and shear envelopes are also presented.

For the design of an exterior girder, the composite section properties must be computed in accordance with S4.6.2.6.

The modular ratio is computed as follows:

$$W_C = 0.150 \text{ kcf}$$

$$f_c = 4.0 \text{ ksi}$$

$$E_C = 33000 \cdot (W_C^{1.5}) \cdot \sqrt{f_c} \qquad E_C = 3834 \text{ ksi}$$

$$E_S = 29000 \text{ ksi}$$

$$n = \frac{E_S}{E_C} \qquad n = 7.6$$

Therefore, use $n = 8$.

In lieu of the above computations, the modular ratio can also be obtained from S6.10.3.1.1b. The above computations are presented simply to illustrate the process. Both the above computations and S6.10.3.1.1b result in a modular ratio of 8.

The effective flange width is computed as follows:

For interior beams, the effective flange width is taken as the least of:

1. One-quarter of the effective span length:

Assume that the minimum, controlling effective span length equals approximately 60 feet (over the pier).

$$\text{Span}_{\text{eff}} = 60 \text{ ft}$$

$$W_{\text{eff1}} = \frac{\text{Span}_{\text{eff}}}{4} \qquad W_{\text{eff1}} = 15.00 \text{ ft}$$

2. 12.0 times the average thickness of the slab, plus the greater of web thickness or one-half the width of the top flange of the girder:

$$W_{\text{eff2}} = 12 \cdot t_{\text{effdeck}} + \frac{14 \text{ in}}{2}$$

$$W_{\text{eff2}} = 8.58 \text{ ft}$$

STable 3.5.1-1

S5.4.2.1 &
STable C5.4.2.1-1

S5.4.2.4

S6.4.1

S6.10.3.1.1b

S4.6.2.6

3. The average spacing of adjacent beams:

$$W_{\text{eff}3} = S \qquad W_{\text{eff}3} = 9.75 \text{ ft}$$

Therefore, the effective flange width is:

$$W_{\text{effflange}} = \min(W_{\text{eff}1}, W_{\text{eff}2}, W_{\text{eff}3})$$

$$W_{\text{effflange}} = 8.58 \text{ ft} \quad \text{or}$$

$$W_{\text{effflange}} = 103.0 \text{ in}$$

Based on the concrete deck design example, the total area of longitudinal deck reinforcing steel in the negative moment region is computed as follows:

$$A_{\text{deckreinf}} = 2 \times 0.31 \cdot \text{in}^2 \cdot \frac{W_{\text{effflange}}}{5 \text{ in}}$$

$$A_{\text{deckreinf}} = 12.772 \text{ in}^2$$



Slab Haunch

For this design example, the slab haunch is 3.5 inches throughout the length of the bridge. That is, the bottom of the slab is located 3.5 inches above the top of the web. For this design example, this distance is used in computing the location of the centroid of the slab. However, the area of the haunch is not considered in the section properties.

Some states and agencies assume that the slab haunch is zero when computing the section properties.

If the haunch depth is not known, it is conservative to assume that the haunch is zero. If the haunch varies, it is reasonable to use either the minimum value or an average value.

Based on the trial plate sizes shown in Figure 3-4, the noncomposite and composite section properties for the positive moment region are computed as shown in the following table. The distance to the centroid is measured from the bottom of the girder.

Positive Moment Region Section Properties						
Section	Area, A (Inches ²)	Centroid, d (Inches)	A*d (Inches ³)	I _o (Inches ⁴)	A*y ² (Inches ⁴)	I _{total} (Inches ⁴)
Girder only:						
Top flange	8.750	55.188	482.9	0.3	7530.2	7530.5
Web	27.000	27.875	752.6	6561.0	110.5	6671.5
Bottom flange	12.250	0.438	5.4	0.8	7912.0	7912.7
Total	48.000	25.852	1240.9	6562.1	15552.7	22114.8
Composite (3n):						
Girder	48.000	25.852	1240.9	22114.8	11134.4	33249.2
Slab	34.333	62.375	2141.5	183.1	15566.5	15749.6
Total	82.333	41.082	3382.4	22297.9	26700.8	48998.7
Composite (n):						
Girder	48.000	25.852	1240.9	22114.8	29792.4	51907.2
Slab	103.000	62.375	6424.6	549.3	13883.8	14433.2
Total	151.000	50.765	7665.5	22664.1	43676.2	66340.3
Section	Y _{botgdr} (Inches)	Y _{topgdr} (Inches)	Y _{topslab} (Inches)	S _{botgdr} (Inches ³)	S _{topgdr} (Inches ³)	S _{topslab} (Inches ³)
Girder only	25.852	29.648	---	855.5	745.9	---
Composite (3n)	41.082	14.418	25.293	1192.7	3398.4	1937.2
Composite (n)	50.765	4.735	15.610	1306.8	14010.3	4249.8

Table 3-4 Positive Moment Region Section Properties

Similarly, the noncomposite and composite section properties for the negative moment region are computed as shown in the following table. The distance to the centroid is measured from the bottom of the girder.

For the strength limit state, since the deck concrete is in tension in the negative moment region, the deck reinforcing steel contributes to the composite section properties and the deck concrete does not.

As previously explained, for this design example, the concrete slab will be assumed to be fully effective for both positive and negative flexure for service and fatigue limit states.

S6.6.1.2.1 &
S6.10.5.1

Negative Moment Region Section Properties						
Section	Area, A (Inches ²)	Centroid, d (Inches)	A*d (Inches ³)	I _o (Inches ⁴)	A*y ² (Inches ⁴)	I _{total} (Inches ⁴)
Girder only:						
Top flange	35.000	58.000	2030.0	18.2	30009.7	30027.9
Web	27.000	29.750	803.3	6561.0	28.7	6589.7
Bottom flange	38.500	1.375	52.9	24.3	28784.7	28809.0
Total	100.500	28.718	2886.2	6603.5	58823.1	65426.6
Composite (deck concrete using 3n):						
Girder	100.500	28.718	2886.2	65426.6	8226.9	73653.5
Slab	34.333	64.250	2205.9	183.1	24081.6	24264.7
Total	134.833	37.766	5092.1	65609.7	32308.5	97918.3
Composite (deck concrete using n):						
Girder	100.500	28.718	2886.2	65426.6	32504.5	97931.2
Slab	103.000	64.250	6617.8	549.3	31715.6	32264.9
Total	203.500	46.702	9503.9	65976.0	64220.1	130196.1
Composite (deck reinforcement only):						
Girder	100.500	28.718	2886.2	65426.6	1568.1	66994.7
Deck reinf.	12.772	63.750	814.2	0.0	12338.7	12338.7
Total	113.272	32.668	3700.4	65426.6	13906.7	79333.4
Section	Y _{botgdr} (Inches)	Y _{topgdr} (Inches)	Y _{deck} (Inches)	S _{botgdr} (Inches ³)	S _{topgdr} (Inches ³)	S _{deck} (Inches ³)
Girder only	28.718	30.532	---	2278.2	2142.9	---
Composite (3n)	37.766	21.484	30.484	2592.8	4557.7	3212.1
Composite (n)	46.702	12.548	21.548	2787.8	10376.2	6042.3
Composite (rebar)	32.668	26.582	31.082	2428.5	2984.5	2552.4

Table 3-5 Negative Moment Region Section Properties

Design Step 3.4 - Compute Dead Load Effects

The girder must be designed to resist the dead load effects, as well as the other load effects. The dead load components consist of some dead loads that are resisted by the noncomposite section, as well as other dead loads that are resisted by the composite section. In addition, some dead loads are factored with the DC load factor and other dead loads are factored with the DW load factor. The following table summarizes the various dead load components that must be included in the design of a steel girder.

Dead Load Components		
Resisted by	Type of Load Factor	
	DC	DW
Noncomposite section	<ul style="list-style-type: none"> • Steel girder • Concrete deck • Concrete haunch • Stay-in-place deck forms • Miscellaneous dead load (including cross-frames, stiffeners, etc.) 	
Composite section	<ul style="list-style-type: none"> • Concrete parapets 	<ul style="list-style-type: none"> • Future wearing surface

Table 3-6 Dead Load Components

For the steel girder, the dead load per unit length varies due to the change in plate sizes. The moments and shears due to the weight of the steel girder can be computed using readily available analysis software. Since the actual plate sizes are entered as input, the moments and shears are computed based on the actual, varying plate sizes.

For the concrete deck, the dead load per unit length for an interior girder is computed as follows:

$$W_c = 0.150 \frac{K}{ft^3} \quad S = 9.8ft \quad t_{deck} = 8.5in$$

$$DL_{deck} = W_c \cdot S \cdot \frac{t_{deck}}{12 \frac{in}{ft}} \quad DL_{deck} = 1.036 \frac{K}{ft}$$

For the concrete haunch, the dead load per unit length varies due to the change in top flange plate sizes. The moments and shears due to the weight of the concrete haunch can be computed using readily available analysis software. Since the top flange plate sizes are entered as input, the moments and shears due to the concrete haunch are computed based on the actual, varying haunch thickness.

For the stay-in-place forms, the dead load per unit length is computed as follows:

$$W_{\text{deckforms}} = 0.015 \text{ ksf} \quad S = 9.8 \text{ ft} \quad W_{\text{topflange}} = 14 \cdot \text{in}$$

$$DL_{\text{deckforms}} = W_{\text{deckforms}} \cdot (S - W_{\text{topflange}})$$

$$DL_{\text{deckforms}} = 0.129 \frac{\text{K}}{\text{ft}}$$

For the miscellaneous dead load (including cross-frames, stiffeners, and other miscellaneous structural steel), the dead load per unit length is assumed to be as follows:

$$DL_{\text{misc}} = 0.015 \frac{\text{K}}{\text{ft}}$$

For the concrete parapets, the dead load per unit length is computed as follows, assuming that the superimposed dead load of the two parapets is distributed uniformly among all of the girders:

S4.6.2.2.1

$$W_{\text{par}} = 0.5 \frac{\text{K}}{\text{ft}} \quad N_{\text{girders}} = 5$$

$$DL_{\text{par}} = W_{\text{par}} \cdot \frac{2}{N_{\text{girders}}} \quad DL_{\text{par}} = 0.212 \frac{\text{K}}{\text{ft}}$$

Although S4.6.2.2.1 specifies that permanent loads of and on the deck may be distributed uniformly among the beams, some states assign a larger percentage of the barrier loads to the exterior girders.

For the future wearing surface, the dead load per unit length is computed as follows, assuming that the superimposed dead load of the future wearing surface is distributed uniformly among all of the girders:

S4.6.2.2.1

$$W_{\text{fws}} = 0.140 \text{ kcf} \quad t_{\text{fws}} = 2.5 \text{ in}$$

$$w_{\text{roadway}} = 44.0 \text{ ft} \quad N_{\text{girders}} = 5$$

$$DL_{\text{fws}} = \frac{W_{\text{fws}} \cdot \frac{t_{\text{fws}}}{12 \cdot \frac{\text{in}}{\text{ft}}} \cdot w_{\text{roadway}}}{N_{\text{girders}}} \quad DL_{\text{fws}} = 0.257 \frac{\text{K}}{\text{ft}}$$

Since the plate girder and its section properties are not uniform over the entire length of the bridge, an analysis must be performed to compute the dead load moments and shears. Such an analysis can be performed using one of various computer programs.



Need for Revised Analysis

It should be noted that during the optimization process, minor adjustments can be made to the plate sizes and transition locations without needing to recompute the analysis results. However, if significant adjustments are made, such that the moments and shears would change significantly, then a revised analysis is required.

The following two tables present the unfactored dead load moments and shears, as computed by an analysis computer program (AASHTO Opis software). Since the bridge is symmetrical, the moments and shears in Span 2 are symmetrical to those in Span 1.

Dead Load Moments (Kip-feet)											
Dead Load Component	Location in Span 1										
	0.0L	0.1L	0.2L	0.3L	0.4L	0.5L	0.6L	0.7L	0.8L	0.9L	1.0L
Steel girder	0.0	75.4	125.5	150.3	150.0	124.4	73.6	-2.5	-107.2	-244.0	-421.5
Concrete deck & haunches	0.0	467.4	776.9	928.6	922.4	758.4	436.6	-43.1	-679.7	-1472.0	-2418.3
Other dead loads acting on girder alone	0.0	68.8	114.3	136.7	135.8	111.7	64.4	-6.2	-99.9	-216.9	-357.1
Concrete parapets	0.0	93.9	157.2	189.9	192.2	163.8	104.9	15.5	-104.5	-255.0	-436.1
Future wearing surface	0.0	113.7	190.4	230.1	232.7	198.4	127.1	18.8	-126.6	-308.9	-528.2

Table 3-7 Dead Load Moments

Dead Load Shears (Kips)											
Dead Load Component	Location in Span 1										
	0.0L	0.1L	0.2L	0.3L	0.4L	0.5L	0.6L	0.7L	0.8L	0.9L	1.0L
Steel girder	7.33	5.23	3.12	1.02	-1.08	-3.18	-5.29	-7.39	-10.06	-12.74	-16.84
Concrete deck & haunches	45.53	32.37	19.22	6.06	-7.09	-20.24	-33.40	-46.55	-59.54	-72.52	-85.18
Other dead loads acting on girder alone	6.70	4.76	2.83	0.89	-1.04	-2.98	-4.91	-6.85	-8.78	-10.72	-12.65
Concrete parapets	9.10	6.55	4.00	1.46	-1.09	-3.63	-6.18	-8.73	-11.27	-13.82	-16.36
Future wearing surface	11.02	7.93	4.85	1.77	-1.32	-4.40	-7.49	-10.57	-13.65	-16.74	-19.82

Table 3-8 Dead Load Shears

Design Step 3.5 - Compute Live Load Effects**LRFD Live Load**

There are several differences between the live load used in Allowable Stress Design (ASD) or Load Factor Design (LFD) and the live load used in Load and Resistance Factor Design (LRFD). Some of the more significant differences are:

- In ASD and LFD, the basic live load designation is HS20 or HS25. In LRFD, the basic live load designation is HL-93.
- In ASD and LFD, the live load consists of either a truck load or a lane load and concentrated loads. In LRFD, the load consists of a design truck or tandem, combined with a lane load.
- In ASD and LFD, the two concentrated loads are combined with lane load to compute the maximum negative live load moment. In LRFD, 90% of the effect of two design trucks at a specified distance is combined with 90% of the lane load to compute the maximum negative live load moment.
- In ASD and LFD, the term "impact" is used for the dynamic interaction between the bridge and the moving vehicles. In LRFD, the term "dynamic load allowance" is used instead of "impact."
- In ASD and LFD, impact is applied to the entire live load. In LRFD, dynamic load allowance is applied only to the design truck and design tandem.

For additional information about the live load used in LRFD, refer to S3.6 and C3.6.

The girder must also be designed to resist the live load effects. The live load consists of an HL-93 loading. Similar to the dead load, the live load moments and shears for an HL-93 loading can be obtained from an analysis computer program.

S3.6.1.2

Based on Table 3-3, for all limit states other than fatigue and fracture, the dynamic load allowance, IM, is as follows:

S3.6.2.1

$$IM = 0.33$$

The live load distribution factors for moment for an interior girder are computed as follows:

S4.6.2.2.2

First, the longitudinal stiffness parameter, K_g , must be computed:

S4.6.2.2.1

$$K_g = n \cdot (I + A \cdot e_g^2)$$

Longitudinal Stiffness Parameter, K_g				
	Region A (Pos. Mom.)	Region B (Intermediate)	Region C (At Pier)	Weighted Average *
Length (Feet)	84	24	12	
n	8	8	8	
I (Inches ⁴)	22,114.8	34,639.8	65,426.6	
A (Inches ²)	48.000	63.750	100.500	
e_g (Inches)	36.523	35.277	35.532	
K_g (Inches ⁴)	689,147	911,796	1,538,481	818,611

Table 3-9 Longitudinal Stiffness Parameter

After the longitudinal stiffness parameter is computed, *S*Table 4.6.2.2.1-1 is used to find the letter corresponding with the superstructure cross section. The letter corresponding with the superstructure cross section in this design example is "a."

If the superstructure cross section does not correspond with any of the cross sections illustrated in *S*Table 4.6.2.2.1-1, then the bridge should be analyzed as presented in S4.6.3.

S4.6.2.2.1

Based on cross section "a," *S*Tables 4.6.2.2.2b-1 and 4.6.2.2.2.3a-1 are used to compute the distribution factors for moment and shear, respectively.

Check the range of applicability as follows:

*S*Table
4.6.2.2.2b-1

$$3.5 \leq S \leq 16.0$$

$$S = 9.75 \quad \text{ft} \quad \text{OK}$$

$$4.5 \leq t_s \leq 12.0$$

$$t_s = 8.0 \quad \text{in} \quad \text{OK}$$

$$20 \leq L \leq 240$$

$$L = 120 \quad \text{ft} \quad \text{OK}$$

$$N_b \geq 4$$

$$N_b = 5 \quad \text{OK}$$

$$10000 \leq K_g \leq 7000000$$

$$K_g = 818611 \quad \text{in}^4 \quad \text{OK}$$

For one design lane loaded, the distribution of live load per lane for moment in interior beams is as follows:

STable
4.6.2.2.2b-1

$$g_{\text{int_moment_1}} = 0.06 + \left(\frac{S}{14}\right)^{0.4} \left(\frac{S}{L}\right)^{0.3} \left[\frac{K_g}{12.0L \cdot (t_s)^3} \right]^{0.1}$$

$$g_{\text{int_moment_1}} = 0.472 \quad \text{lanes}$$

For two or more design lanes loaded, the distribution of live load per lane for moment in interior beams is as follows:

STable
4.6.2.2.2b-1

$$g_{\text{int_moment_2}} = 0.075 + \left(\frac{S}{9.5}\right)^{0.6} \left(\frac{S}{L}\right)^{0.2} \left[\frac{K_g}{12.0 \cdot L \cdot (t_s)^3} \right]^{0.1}$$

$$g_{\text{int_moment_2}} = 0.696 \quad \text{lanes}$$

The live load distribution factors for shear for an interior girder are computed in a similar manner. The range of applicability is similar to that for moment.

STable
4.6.2.2.3a-1

For one design lane loaded, the distribution of live load per lane for shear in interior beams is as follows:

STable
4.6.2.2.3a-1

$$g_{\text{int_shear_1}} = 0.36 + \frac{S}{25.0}$$

$$g_{\text{int_shear_1}} = 0.750 \quad \text{lanes}$$

For two or more design lanes loaded, the distribution of live load per lane for shear in interior beams is as follows:

STable
4.6.2.2.3a-1

$$g_{\text{int_shear_2}} = 0.2 + \frac{S}{12} - \left(\frac{S}{35}\right)^{2.0}$$

$$g_{\text{int_shear_2}} = 0.935 \quad \text{lanes}$$

Since this bridge has no skew, the skew correction factor does not need to be considered for this design example.

S4.6.2.2.2e,
S4.6.2.2.3c

This design example is based on an interior girder. However, for illustrative purposes, the live load distribution factors for an exterior girder are computed below, as follows:

S4.6.2.2.2

The distance, d_e , is defined as the distance between the web centerline of the exterior girder and the interior edge of the curb. For this design example, based on Figure 3-2:

$$d_e = 2.50\text{ft}$$

Check the range of applicability as follows:

$$-1.0 \leq d_e \leq 5.5$$

$$d_e = 2.50 \text{ ft} \quad \text{OK}$$

S4.6.2.2.2d-1

For one design lane loaded, the distribution of live load per lane for moment in exterior beams is computed using the lever rule, as follows:

S4.6.2.2.2d-1

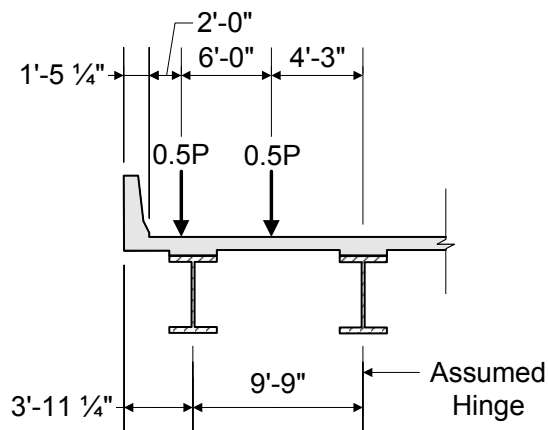

Figure 3-5 Lever Rule

$$g_{\text{ext_moment}_1} = \frac{(0.5) \cdot (4.25 \cdot \text{ft}) + (0.5) \cdot (10.25 \cdot \text{ft})}{9.75 \cdot \text{ft}}$$

$$g_{\text{ext_moment}_1} = 0.744 \quad \text{lanes}$$

$$\text{Multiple_presence_factor} = 1.20$$

$$g_{\text{ext_moment}_1} = g_{\text{ext_moment}_1} \cdot \text{Multiple_presence_factor}$$

$$g_{\text{ext_moment}_1} = 0.892 \quad \text{lanes} \quad (\text{for strength limit state})$$

For two or more design lanes loaded, the distribution of live load per lane for moment in exterior beams is as follows:

$$e = 0.77 + \frac{d_e}{9.1} \qquad e = 1.045$$

$$g_{\text{ext_moment_2}} = e \cdot g_{\text{int_moment_2}}$$

$$g_{\text{ext_moment_2}} = 0.727 \quad \text{lanes}$$

The live load distribution factors for shear for an exterior girder are computed in a similar manner. The range of applicability is similar to that for moment.

For one design lane loaded, the distribution of live load per lane for shear in exterior beams is computed using the lever rule, as illustrated in Figure 3-5 and as follows:

$$g_{\text{ext_shear_1}} = \frac{(0.5) \cdot (4.25 \cdot \text{ft}) + (0.5) \cdot (10.25 \cdot \text{ft})}{9.75 \cdot \text{ft}}$$

$$g_{\text{ext_shear_1}} = 0.744 \quad \text{lanes}$$

$$\text{Multiple_presence_factor} = 1.20$$

$$g_{\text{ext_shear_1}} = g_{\text{ext_shear_1}} \cdot \text{Multiple_presence_factor}$$

$$g_{\text{ext_shear_1}} = 0.892 \quad \text{lanes} \quad (\text{for strength limit state})$$

For two or more design lanes loaded, the distribution of live load per lane for shear in exterior beams is as follows:

$$e = 0.6 + \frac{d_e}{10} \qquad e = 0.850$$

$$g_{\text{ext_shear_2}} = e \cdot g_{\text{int_shear_2}}$$

$$g_{\text{ext_shear_2}} = 0.795 \quad \text{lanes}$$

In beam-slab bridge cross-sections with diaphragms or cross-frames, the distribution factor for the exterior beam can not be taken to be less than that which would be obtained by assuming that the cross-section deflects and rotates as a rigid cross-section. *CEquation 4.6.2.2.2d-1* provides one approximate approach to satisfy this requirement. The multiple presence factor provisions of *S3.6.1.1.2* must be applied when this equation is used.

STable
4.6.2.2.2d-1

STable
4.6.2.2.3b-1

STable
4.6.2.2.3b-1

STable
4.6.2.2.3b-1

S4.6.2.2.2d

Since this bridge has no skew, the skew correction factor does not need to be considered for this design example.

The following table presents the unfactored maximum positive and negative live load moments and shears for HL-93 live loading for interior beams, as computed using an analysis computer program. These values include the live load distribution factor, and they also include dynamic load allowance. Since the bridge is symmetrical, the moments and shears in Span 2 are symmetrical to those in Span 1.

S4.6.2.2.2e,
S4.6.2.2.3c

Live Load Effects (for Interior Beams)											
Live Load Effect	Location in Span 1										
	0.0L	0.1L	0.2L	0.3L	0.4L	0.5L	0.6L	0.7L	0.8L	0.9L	1.0L
Maximum positive moment (K-ft)	0	836	1422	1766	1908	1857	1628	1318	1006	865	983
Maximum negative moment (K-ft)	0	-324	-583	-777	-905	-968	-966	-966	-1097	-1593	-2450
Maximum positive shear (kips)	110.5	93.7	76.6	61.0	49.6	42.5	37.1	33.5	32.1	33.0	35.8
Maximum negative shear (kips)	-33.8	-28.7	-29.1	-36.4	-47.8	-62.2	-76.7	-91.1	-105.1	-118.5	-131.4

Table 3-10 Live Load Effects

The design live load values for HL-93 loading, as presented in the previous table, are computed based on the product of the live load effect per lane and live load distribution factor. These values also include the effects of dynamic load allowance. However, it is important to note that the dynamic load allowance is applied only to the design truck or tandem. The dynamic load allowance is not applied to pedestrian loads or to the design lane load.

S3.6.1,
S3.6.2,
S4.6.2.2

Design Step 3.6 - Combine Load Effects

After the load factors and load combinations have been established (see Design Step 3.1), the section properties have been computed (see Design Step 3.3), and all of the load effects have been computed (see Design Steps 3.4 and 3.5), the force effects must be combined for each of the applicable limit states.

For this design example, η equals 1.00. (For more detailed information about η , refer to Design Step 1.)

S1.3

Based on the previous design steps, the maximum positive moment (located at 0.4L) for the Strength I Limit State is computed as follows:

S3.4.1

$$LF_{DC} = 1.25$$

$$M_{DC} = 150.0K \cdot ft + 922.4K \cdot ft + 135.8K \cdot ft \dots \\ + 192.2K \cdot ft$$

$$M_{DC} = 1400.4 K \cdot ft$$

$$LF_{DW} = 1.50$$

$$M_{DW} = 232.7K \cdot ft$$

$$LF_{LL} = 1.75$$

$$M_{LL} = 1908K \cdot ft$$

$$M_{total} = LF_{DC} \cdot M_{DC} + LF_{DW} \cdot M_{DW} + LF_{LL} \cdot M_{LL}$$

$$M_{total} = 5439 K \cdot ft$$

Similarly, the maximum stress in the top of the girder due to positive moment (located at 0.4L) for the Strength I Limit State is computed as follows:

Noncomposite dead load:

$$M_{\text{noncompDL}} = 150.0\text{K}\cdot\text{ft} + 922.4\text{K}\cdot\text{ft} + 135.8\text{K}\cdot\text{ft}$$

$$M_{\text{noncompDL}} = 1208.2\text{K}\cdot\text{ft}$$

$$S_{\text{topgdr}} = 745.9\cdot\text{in}^3$$

$$f_{\text{noncompDL}} = \frac{-M_{\text{noncompDL}} \cdot \left(\frac{12\cdot\text{in}}{\text{ft}}\right)}{S_{\text{topgdr}}}$$

$$f_{\text{noncompDL}} = -19.44\text{ ksi}$$

Parapet dead load (composite):

$$M_{\text{parapet}} = 192.2\text{K}\cdot\text{ft} \quad S_{\text{topgdr}} = 3398.4\text{in}^3$$

$$f_{\text{parapet}} = \frac{-M_{\text{parapet}} \cdot \left(\frac{12\cdot\text{in}}{\text{ft}}\right)}{S_{\text{topgdr}}} \quad f_{\text{parapet}} = -0.68\text{ ksi}$$

Future wearing surface dead load (composite):

$$M_{\text{fws}} = 232.7\text{K}\cdot\text{ft} \quad S_{\text{topgdr}} = 3398.4\text{in}^3$$

$$f_{\text{fws}} = \frac{-M_{\text{fws}} \cdot \left(\frac{12\cdot\text{in}}{\text{ft}}\right)}{S_{\text{topgdr}}} \quad f_{\text{fws}} = -0.82\text{ ksi}$$

Live load (HL-93) and dynamic load allowance:

$$M_{\text{LL}} = 1908\text{K}\cdot\text{ft}$$

$$S_{\text{topgdr}} = 14010.3\text{in}^3$$

$$f_{\text{LL}} = \frac{-M_{\text{LL}} \cdot \left(\frac{12\cdot\text{in}}{\text{ft}}\right)}{S_{\text{topgdr}}} \quad f_{\text{LL}} = -1.63\text{ ksi}$$

S3.4.1

Multiplying the above stresses by their respective load factors and adding the products results in the following combined stress for the Strength I Limit State:

$$f_{Str} = (LF_{DC} \cdot f_{noncompDL}) + (LF_{DC} \cdot f_{parapet}) \dots \\ + (LF_{DW} \cdot f_{ws}) + (LF_{LL} \cdot f_{LL})$$

$$f_{Str} = -29.24 \text{ ksi}$$

Similarly, all of the combined moments, shears, and flexural stresses can be computed at the controlling locations. A summary of those combined load effects for an interior beam is presented in the following three tables, summarizing the results obtained using the procedures demonstrated in the above computations.

Combined Effects at Location of Maximum Positive Moment				
Summary of Unfactored Values:				
Loading	Moment (K-ft)	f_{botgdr} (ksi)	f_{topgdr} (ksi)	$f_{topslab}$ (ksi)
Noncomposite DL	1208	16.95	-19.44	0.00
Parapet DL	192	1.93	-0.68	-0.05
FWS DL	233	2.34	-0.82	-0.06
LL - HL-93	1908	17.52	-1.63	-0.67
LL - Fatigue	563	5.17	-0.48	-0.20
Summary of Factored Values:				
Limit State	Moment (K-ft)	f_{botgdr} (ksi)	f_{topgdr} (ksi)	$f_{topslab}$ (ksi)
Strength I	5439	57.77	-29.24	-1.33
Service II	4114	44.00	-23.06	-0.99
Fatigue	422	3.87	-0.36	-0.15

Table 3-11 Combined Effects at Location of Maximum Positive Moment

As shown in the above table, the Strength I Limit State elastic stress in the bottom of the girder exceeds the girder yield stress. However, for this design example, this value is not used because of the local yielding that occurs at this section.

Combined Effects at Location of Maximum Negative Moment				
Summary of Unfactored Values (Assuming Concrete Not Effective):				
Loading	Moment (K-ft)	f_{botgdr} (ksi)	f_{topgdr} (ksi)	f_{deck} (ksi)
Noncomposite DL	-3197	-16.84	17.90	0.00
Parapet DL	-436	-2.15	1.75	2.05
FWS DL	-528	-2.61	2.12	2.48
LL - HL-93	-2450	-12.11	9.85	11.52
Summary of Unfactored Values (Assuming Concrete Effective):				
Loading	Moment (K-ft)	f_{botgdr} (ksi)	f_{topgdr} (ksi)	f_{deck} (ksi)
Noncomposite DL	-3197	-16.84	17.90	0.00
Parapet DL	-436	-2.02	1.15	0.07
FWS DL	-528	-2.44	1.39	0.08
LL - HL-93	-2450	-10.55	2.83	0.61
LL - Fatigue	-406	-1.75	0.47	0.10
Summary of Factored Values:				
Limit State	Moment (K-ft)	f_{botgdr} (ksi)	f_{topgdr} (ksi)	f_{deck} (ksi)
Strength I *	-9621	-48.84	44.99	26.44
Service II **	-7346	-35.01	24.12	0.94
Fatigue **	-305	-1.31	0.35	0.08

Legend:

- * Strength I Limit State stresses are based on section properties assuming the deck concrete is not effective, and f_{deck} is the stress in the deck reinforcing steel.
- ** Service II and Fatigue Limit State stresses are based on section properties assuming the deck concrete is effective, and f_{deck} is the stress in the deck concrete.

Table 3-12 Combined Effects at Location of Maximum Negative Moment

Combined Effects at Location of Maximum Shear	
Summary of Unfactored Values:	
Loading	Shear (kips)
Noncomposite DL	114.7
Parapet DL	16.4
FWS DL	19.8
LL - HL-93	131.4
LL - Fatigue	46.5
Summary of Factored Values:	
Limit State	Shear (kips)
Strength I	423.5
Service II	321.7
Fatigue	34.8

Table 3-13 Combined Effects at Location of Maximum Shear

Envelopes of the factored Strength I moments and shears are presented in the following two figures. Maximum and minimum values are presented, and values for both interior and exterior girders are presented. Based on these envelopes, it can be seen that the interior girder controls the design, and all remaining design computations are based on the interior girder.

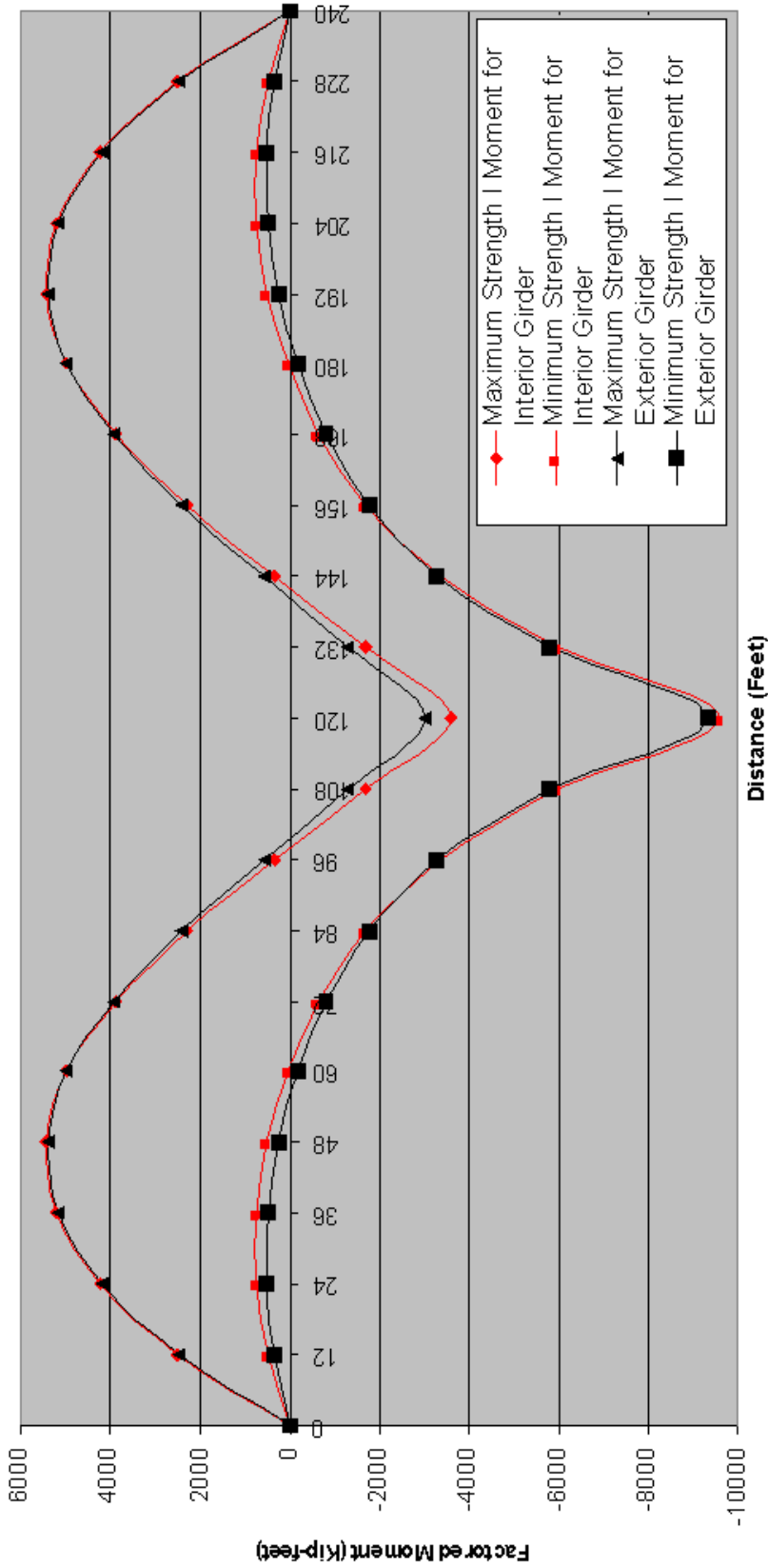

Figure 3-6 Envelope of Strength I Moments

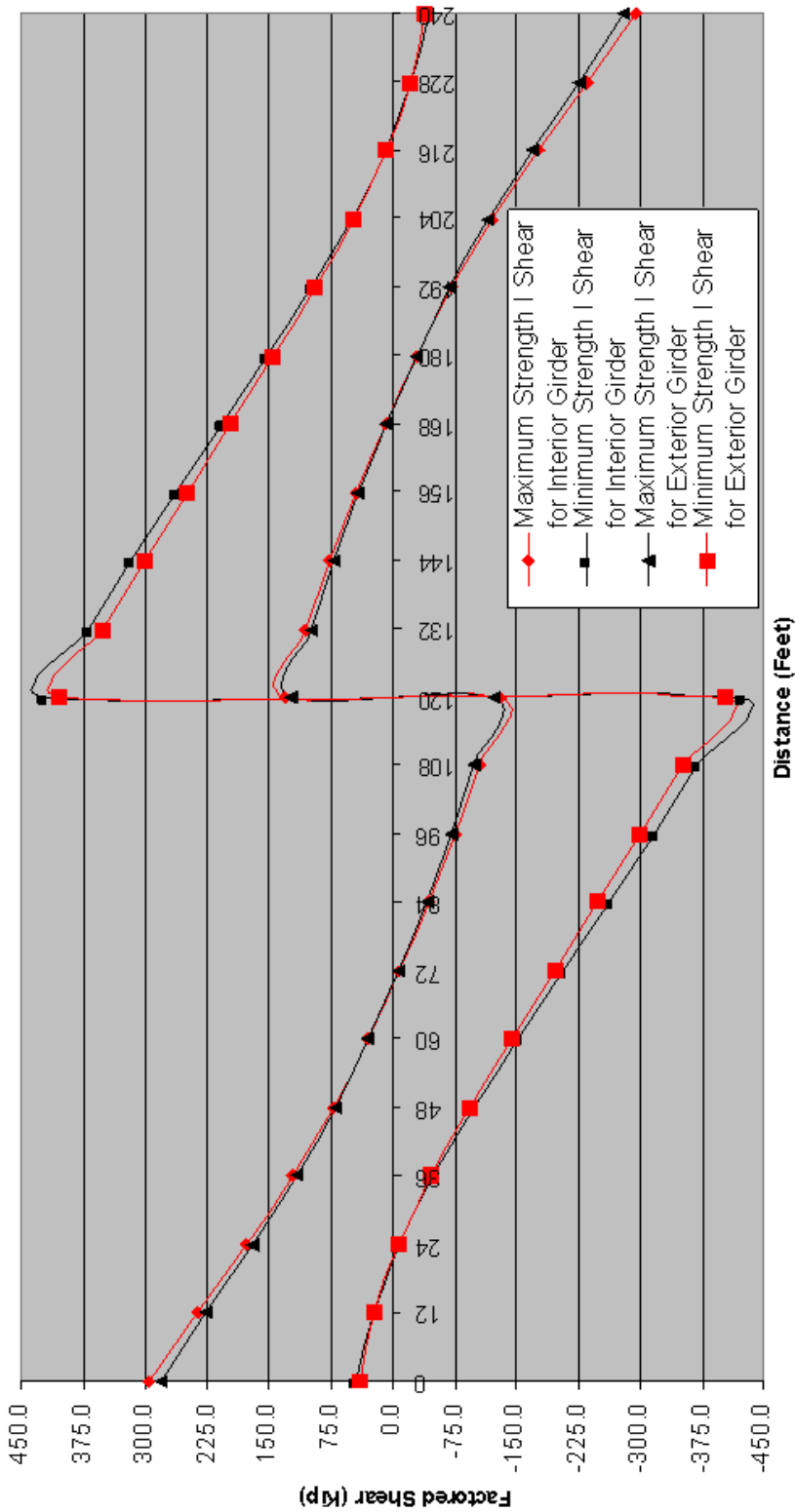

Figure 3-7 Envelope of Strength I Shears

Design Steps 3.7 through 3.17 consist of verifying the structural adequacy of critical beam locations using appropriate sections of the Specifications.

For this design example, two design sections will be checked for illustrative purposes. First, all specification checks for Design Steps 3.7 through 3.17 will be performed for the location of maximum positive moment, which is at $0.4L$ in Span 1. Second, all specification checks for these same design steps will be performed for the location of maximum negative moment and maximum shear, which is at the pier.



Specification Check Locations

For steel girder designs, specification checks are generally performed using a computer program at the following locations:

- Span tenth points
- Locations of plate transitions
- Locations of stiffener spacing transitions

However, it should be noted that the maximum moment within a span may not necessarily occur at any of the above locations.

The following specification checks are for the location of maximum positive moment, which is at $0.4L$ in Span 1, as shown in Figure 3-8.

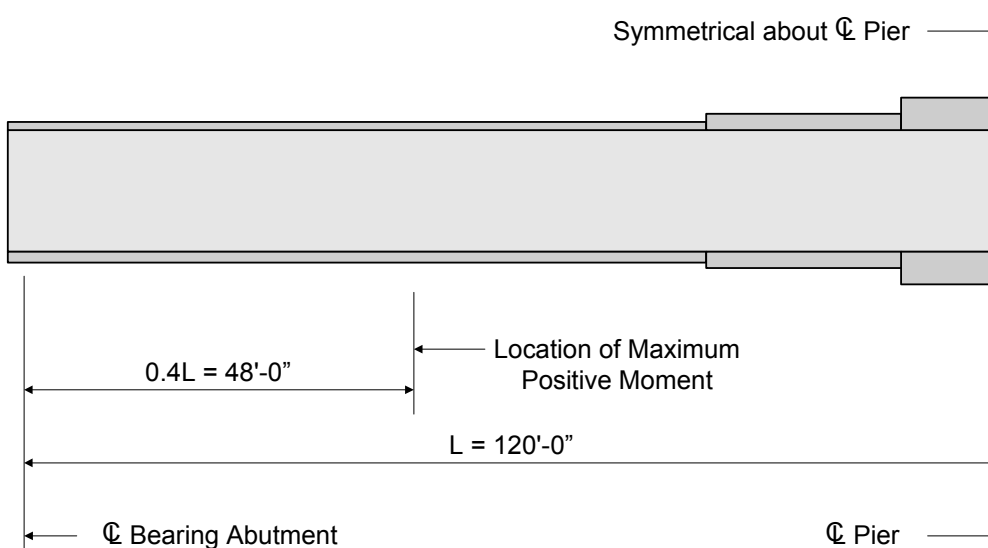

Figure 3-8 Location of Maximum Positive Moment

Design Step 3.7 - Check Section Proportion Limits - Positive Moment Region

Several checks are required to ensure that the proportions of the trial girder section are within specified limits.

S6.10.2

The first section proportion check relates to the general proportions of the section. The flexural components must be proportioned such that:

S6.10.2.1

$$0.1 \leq \frac{I_{yc}}{I_y} \leq 0.9$$

$$I_{yc} = \frac{0.625 \cdot \text{in} \cdot (14 \cdot \text{in})^3}{12} \quad I_{yc} = 142.9 \text{ in}^4$$

$$I_y = \frac{0.625 \cdot \text{in} \cdot (14 \cdot \text{in})^3}{12} + \frac{54 \cdot \text{in} \cdot \left(\frac{1}{2} \cdot \text{in}\right)^3}{12} + \frac{0.875 \cdot \text{in} \cdot (14 \cdot \text{in})^3}{12}$$

$$I_y = 343.6 \text{ in}^4$$

$$\frac{I_{yc}}{I_y} = 0.416 \quad \text{OK}$$

The second section proportion check relates to the web slenderness. For a section without longitudinal stiffeners, the web must be proportioned such that:

S6.10.2.2

$$\frac{2 \cdot D_c}{t_w} \leq 6.77 \cdot \sqrt{\frac{E}{f_c}} \leq 200$$

For the Strength I limit state at 0.4L in Span 1 (the location of maximum positive moment):

S6.10.3.1.4a

$$f_{\text{botgdr}} = 57.77 \cdot \text{ksi} \quad (\text{see Table 3-11 and explanation below table})$$

$$f_{\text{topgdr}} = -29.24 \cdot \text{ksi} \quad (\text{see Table 3-11})$$

$$t_{\text{topfl}} = 0.625 \text{ in} \quad (\text{see Figure 3-4})$$

$$D_{\text{web}} = 54 \text{ in} \quad (\text{see Figure 3-4})$$

$$t_{\text{botfl}} = 0.875 \text{ in} \quad (\text{see Figure 3-4})$$

$$\text{Depth}_{\text{gdr}} = t_{\text{topfl}} + D_{\text{web}} + t_{\text{botfl}}$$

$$\text{Depth}_{\text{gdr}} = 55.50 \text{ in}$$

$$\text{Depth}_{\text{comp}} = \frac{-f_{\text{topgdr}}}{f_{\text{botgdr}} - f_{\text{topgdr}}} \cdot \text{Depth}_{\text{gdr}}$$

C6.10.3.1.4a

$$\text{Depth}_{\text{comp}} = 18.65 \text{ in}$$

$$D_{\text{c}} = \text{Depth}_{\text{comp}} - t_{\text{topfl}}$$

$$D_{\text{c}} = 18.03 \text{ in}$$

$$t_{\text{w}} = \frac{1}{2} \text{ in} \quad (\text{see Figure 3-4})$$

$$E = 29000 \text{ ksi}$$

S6.4.1

$$f_{\text{c}} = -f_{\text{topgdr}}$$

$$f_{\text{c}} = 29.24 \text{ ksi}$$

$$\frac{2 \cdot D_{\text{c}}}{t_{\text{w}}} = 72.1$$

$$6.77 \cdot \sqrt{\frac{E}{f_{\text{c}}}} = 213.2$$

$$\frac{2 \cdot D_{\text{c}}}{t_{\text{w}}} \leq 6.77 \cdot \sqrt{\frac{E}{f_{\text{c}}}} \quad \text{and} \quad \frac{2 \cdot D_{\text{c}}}{t_{\text{w}}} \leq 200 \quad \text{OK}$$

The third section proportion check relates to the flange proportions. The compression flanges on fabricated I-sections must be proportioned such that:

S6.10.2.3

$$b_{\text{f}} \geq 0.3 \cdot D_{\text{c}}$$

$$b_{\text{f}} = 14 \text{ in} \quad (\text{see Figure 3-4})$$

$$D_{\text{c}} = 18.03 \text{ in}$$

$$0.3 \cdot D_{\text{c}} = 5.41 \text{ in}$$

$$b_{\text{f}} \geq 0.3 \cdot D_{\text{c}} \quad \text{OK}$$

According to C6.10.2.3, it is preferable for the flange width to be greater than or equal to $0.4D_c$. In this case, the flange width is greater than both $0.3D_c$ and $0.4D_c$, so this requirement is clearly satisfied.

C6.10.2.3

In addition to the compression flange check, the tension flanges on fabricated I-sections must be proportioned such that:

S6.10.2.3

$$\frac{b_t}{2 \cdot t_t} \leq 12.0$$

$$b_t = 14\text{in} \quad (\text{see Figure 3-4})$$

$$t_t = 0.875\text{in} \quad (\text{see Figure 3-4})$$

$$\frac{b_t}{2 \cdot t_t} = 8.0 \quad \text{OK}$$

Design Step 3.8 - Compute Plastic Moment Capacity - Positive Moment Region

For composite sections, the plastic moment, M_p , is calculated as the first moment of plastic forces about the plastic neutral axis.

S6.10.3.1.3

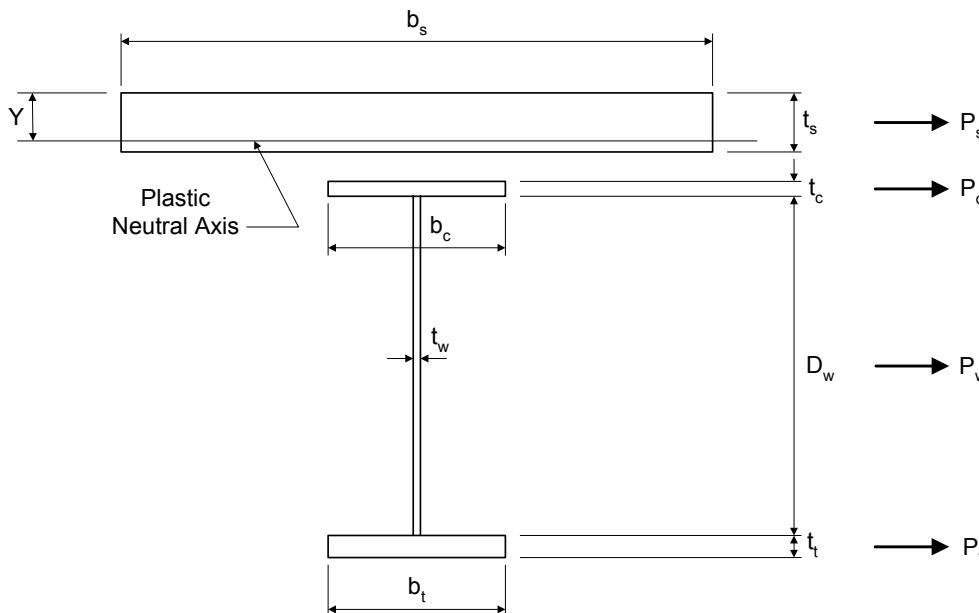

Figure 3-9 Computation of Plastic Moment Capacity for Positive Bending Sections

For the tension flange:

$$F_{yt} = 50 \text{ ksi} \quad b_t = 14 \text{ in} \quad t_t = 0.875 \text{ in}$$

$$P_t = F_{yt} \cdot b_t \cdot t_t \quad P_t = 613 \text{ K}$$

For the web:

$$F_{yw} = 50.0 \text{ ksi} \quad D_w = 54 \text{ in} \quad t_w = 0.50 \text{ in}$$

$$P_w = F_{yw} \cdot D_w \cdot t_w \quad P_w = 1350 \text{ K}$$

For the compression flange:

$$F_{yc} = 50 \text{ ksi} \quad b_c = 14 \text{ in} \quad t_c = 0.625 \text{ in}$$

$$P_c = F_{yc} \cdot b_c \cdot t_c \quad P_c = 438 \text{ K}$$

For the slab:

$$f_c = 4.0 \text{ ksi} \quad b_s = 103 \text{ in} \quad t_s = 8.0 \text{ in}$$

$$P_s = 0.85 \cdot f_c \cdot b_s \cdot t_s \quad P_s = 2802 \text{ K}$$

The forces in the longitudinal reinforcement may be conservatively neglected.

Check the location of the plastic neutral axis, as follows:

$$P_t + P_w = 1963 \text{ K} \quad P_c + P_s = 3239 \text{ K}$$

$$P_t + P_w + P_c = 2400 \text{ K} \quad P_s = 2802 \text{ K}$$

Therefore, the plastic neutral axis is located within the slab.

$$Y = (t_s) \cdot \left(\frac{P_c + P_w + P_t}{P_s} \right)$$

$$Y = 6.85 \text{ in}$$

Check that the position of the plastic neutral axis, as computed above, results in an equilibrium condition in which there is no net axial force.

$$\text{Compression} = 0.85 \cdot f_c \cdot b_s \cdot Y$$

$$\text{Compression} = 2400 \text{ K}$$

$$\text{Tension} = P_t + P_w + P_c$$

$$\text{Tension} = 2400 \text{ K}$$

OK

SAppendix A6.1

C6.10.3.1.3

SAppendix A6.1

*S*Table A6.1-1

The plastic moment, M_p , is computed as follows, where d is the distance from an element force (or element neutral axis) to the plastic neutral axis:

$$d_c = \frac{-t_c}{2} + 3.5\text{in} + t_s - Y \quad d_c = 4.33\text{in}$$

$$d_w = \frac{D_w}{2} + 3.5\text{in} + t_s - Y \quad d_w = 31.65\text{in}$$

$$d_t = \frac{t_t}{2} + D_w + 3.5\text{in} + t_s - Y \quad d_t = 59.08\text{in}$$

$$M_p = \frac{Y^2 \cdot P_s}{2 \cdot t_s} + (P_c \cdot d_c + P_w \cdot d_w + P_t \cdot d_t)$$

$$M_p = 7419\text{K}\cdot\text{ft}$$

Design Step 3.9 - Determine if Section is Compact or Noncompact - Positive Moment Region

The next step in the design process is to determine if the section is compact or noncompact. This, in turn, will determine which formulae should be used to compute the flexural capacity of the girder.

Where the specified minimum yield strength does not exceed 70.0 ksi, and the girder has a constant depth, and the girder does not have longitudinal stiffeners or holes in the tension flange, then the first step is to check the compact-section web slenderness provisions, as follows:

$$\frac{2 \cdot D_{cp}}{t_w} \leq 3.76 \cdot \sqrt{\frac{E}{F_{yc}}}$$

Since the plastic neutral axis is located within the slab,

$$D_{cp} = 0\text{in}$$

Therefore the web is deemed compact. Since this is a composite section in positive flexure, the flexural resistance is computed as defined by the composite compact-section positive flexural resistance provisions of S6.10.4.2.2.

For composite sections in positive flexure in their final condition, the provisions of S6.10.4.1.3, S6.10.4.1.4, S6.10.4.1.6a, S6.10.4.1.7, and S6.10.4.1.9 are considered to be automatically satisfied.

The section is therefore considered to be compact.

*S*Table A6.1-1

S6.10.4.1.1

S6.10.4.1.2

S6.10.4.1.2

*C*Figure
6.10.4-1

Design Step 3.10 - Design for Flexure - Strength Limit State - Positive Moment Region

Since the section was determined to be compact, and since it is a composite section in the positive moment region, the flexural resistance is computed in accordance with the provisions of S6.10.4.2.2.

This is neither a simple span nor a continuous span with compact sections in the negative flexural region over the interior supports. (This will be proven in the negative flexure region computations of this design example.) Therefore, the nominal flexural resistance is determined using the following equation, based on the approximate method:

$$M_n = 1.3 \cdot R_h \cdot M_y$$

All design sections of this girder are homogenous. That is, the same structural steel is used for the top flange, the web, and the bottom flange. Therefore, the hybrid factor, R_h , is as follows:

$$R_h = 1.0$$

The yield moment, M_y , is computed as follows:

$$F_y = \frac{M_{D1}}{S_{NC}} + \frac{M_{D2}}{S_{LT}} + \frac{M_{AD}}{S_{ST}}$$

$$M_y = M_{D1} + M_{D2} + M_{AD}$$

$$F_y = 50 \text{ ksi}$$

$$M_{D1} = (1.25 \cdot 1208 \text{ K} \cdot \text{ft})$$

$$M_{D1} = 1510 \text{ K} \cdot \text{ft}$$

$$M_{D2} = (1.25 \cdot 192 \text{ K} \cdot \text{ft}) + (1.50 \cdot 233 \text{ K} \cdot \text{ft})$$

$$M_{D2} = 590 \text{ K} \cdot \text{ft}$$

For the bottom flange:

$$S_{NC} = 855.5 \cdot \text{in}^3$$

$$S_{LT} = 1192.7 \cdot \text{in}^3$$

$$S_{ST} = 1306.8 \cdot \text{in}^3$$

SFigure
C6.10.4-1

S6.10.4.2.2a

S6.10.4.3.1

SAppendix A6.2

$$M_{AD} = \left[S_{ST} \cdot \left(F_y - \frac{M_{D1}}{S_{NC}} - \frac{M_{D2}}{S_{LT}} \right) \right] \cdot \left(\frac{1 \text{ ft}}{12 \text{ in}} \right)$$

$$M_{AD} = 2493 \text{ K}\cdot\text{ft}$$

$$M_{ybot} = M_{D1} + M_{D2} + M_{AD}$$

$$M_{ybot} = 4592 \text{ K}\cdot\text{ft}$$

For the top flange:

$$S_{NC} = 745.9 \cdot \text{in}^3$$

$$S_{LT} = 3398.4 \cdot \text{in}^3$$

$$S_{ST} = 14010.3 \cdot \text{in}^3$$

$$M_{AD} = S_{ST} \cdot \left(F_y - \frac{M_{D1}}{S_{NC}} - \frac{M_{D2}}{S_{LT}} \right)$$

$$M_{AD} = 27584 \text{ K}\cdot\text{ft}$$

$$M_{ytop} = M_{D1} + M_{D2} + M_{AD}$$

$$M_{ytop} = 29683 \text{ K}\cdot\text{ft}$$

The yield moment, M_y , is the lesser value computed for both flanges. Therefore, M_y is determined as follows:

$$M_y = \min(M_{ybot}, M_{ytop})$$

$$M_y = 4592 \text{ K}\cdot\text{ft}$$

Therefore, for the positive moment region of this design example, the nominal flexural resistance is computed as follows:

$$M_n = 1.3 \cdot R_h \cdot M_y$$

$$M_n = 5970 \text{ K}\cdot\text{ft}$$

SAppendix A6.2

S6.10.4.2.2a

In addition, the nominal flexural resistance can not be taken to be greater than the applicable value of M_n computed from either *SEquation 6.10.4.2.2a-1* or *6.10.4.2.2a-2*.

$$D_p = Y \quad D_p = 6.85 \text{ in}$$

$$D' = \beta \cdot \frac{(d + t_s + t_h)}{7.5}$$

$$\beta = 0.7 \quad \text{for } F_y = 50 \text{ ksi}$$

$$d = \text{Depth}_{\text{gdr}} \quad d = 55.50 \text{ in}$$

$$t_s = 8.0 \text{ in}$$

$$t_h = 3.5 \cdot \text{in} - 0.625 \cdot \text{in} \quad t_h = 2.875 \text{ in}$$

$$D' = \beta \cdot \frac{(d + t_s + t_h)}{7.5}$$

$$D' = 6.19 \text{ in}$$

$$5 \cdot D' = 30.97 \text{ in}$$

$$\text{Therefore} \quad D' \leq D_p \leq 5 \cdot D'$$

$$M_n = \frac{5 \cdot M_p - 0.85 \cdot M_y}{4} + \frac{0.85 \cdot M_y - M_p}{4} \cdot \left(\frac{D_p}{D'} \right)$$

$$M_n = 7326 \text{ K} \cdot \text{ft}$$

$$\text{Therefore, use} \quad M_n = 5970 \cdot \text{K} \cdot \text{ft}$$

The ductility requirement in *S6.10.4.2.2b* is checked as follows:

$$\frac{D_p}{D'} = 1.1 \quad \frac{D_p}{D'} \leq 5 \quad \text{OK}$$

The factored flexural resistance, M_r , is computed as follows:

$$\phi_f = 1.00$$

$$M_r = \phi_f \cdot M_n$$

$$M_r = 5970 \text{ K} \cdot \text{ft}$$

S6.10.4.2.2a

S6.10.4.2.2b

S6.10.4.2.2a

S6.10.4.2.2b

S6.10.4

S6.5.4.2

The positive flexural resistance at this design section is checked as follows:

$$\sum \eta_i \cdot \gamma_i \cdot Q_i \leq R_r$$

or in this case:

$$\sum \eta_i \cdot \gamma_i \cdot M_i \leq M_r$$

For this design example,

$$\eta_i = 1.00$$

As computed in Design Step 3.6,

$$\sum \gamma_i \cdot M_i = 5439 \text{ K}\cdot\text{ft}$$

Therefore $\sum \eta_i \cdot \gamma_i \cdot M_i = 5439 \text{ K}\cdot\text{ft}$

$$M_r = 5970 \text{ K}\cdot\text{ft}$$

OK

S1.3.2.1



Available Plate Thicknesses

Based on the above computations, the flexural resistance is approximately 10% greater than the factored design moment, yielding a slightly conservative design. This degree of conservatism can generally be adjusted by changing the plate dimensions as needed.

However, for this design example, the web dimensions and the flange width were set based on the girder design requirements at the pier. In addition, the flange thicknesses could not be reduced any further due to limitations in plate thicknesses or because such a reduction would result in a specification check failure.

Available plate thicknesses can be obtained from steel fabricators. As a rule of thumb, the following plate thicknesses are generally available from steel fabricators:

3/16" to 3/4" - increments of 1/16"

3/4" to 1 1/2" - increments of 1/8"

1 1/2" to 4" - increments of 1/4"

Design Step 3.11 - Design for Shear - Positive Moment Region

Shear must be checked at each section of the girder. However, shear is minimal at the location of maximum positive moment, and it is maximum at the pier.

Therefore, for this design example, the required shear design computations will be presented later for the girder design section at the pier.

It should be noted that in end panels, the shear is limited to either the shear yield or shear buckling in order to provide an anchor for the tension field in adjacent interior panels. Tension field is not allowed in end panels. The design procedure for shear in the end panel is presented in *S6.10.7.3.3c*.

S6.10.7

S6.10.7.3.3c

Design Step 3.12 - Design Transverse Intermediate Stiffeners - Positive Moment Region

The girder in this design example has transverse intermediate stiffeners. Transverse intermediate stiffeners are used to increase the shear resistance of the girder.

As stated above, shear is minimal at the location of maximum positive moment but is maximum at the pier. Therefore, the required design computations for transverse intermediate stiffeners will be presented later for the girder design section at the pier.

S6.10.8.1

Design Step 3.14 - Design for Flexure - Fatigue and Fracture Limit State - Positive Moment Region

Load-induced fatigue must be considered in a plate girder design. Fatigue considerations for plate girders may include:

1. Welds connecting the shear studs to the girder.
2. Welds connecting the flanges and the web.
3. Welds connecting the transverse intermediate stiffeners to the girder.

S6.6.1

The specific fatigue considerations depend on the unique characteristics of the girder design. Specific fatigue details and detail categories are explained and illustrated in *S*Table 6.6.1.2.3-1 and in *S*Figure 6.6.1.2.3-1.

*S*Table
6.6.1.2.3-1

*S*Figure
6.6.1.2.3-1

For this design example, fatigue will be checked for the fillet-welded connection of the transverse intermediate stiffeners to the girder. This detail corresponds to Illustrative Example 6 in *SFigure 6.6.1.2.3-1*, and it is classified as Detail Category C' in *STable 6.6.1.2.3-1*.

For this design example, the fillet-welded connection of the transverse intermediate stiffeners will be checked at the location of maximum positive moment. The fatigue detail is located at the inner fiber of the tension flange, where the transverse intermediate stiffener is welded to the flange. However, for simplicity, the computations will conservatively compute the fatigue stress at the outer fiber of the tension flange.

The fatigue detail being investigated in this design example is illustrated in the following figure:

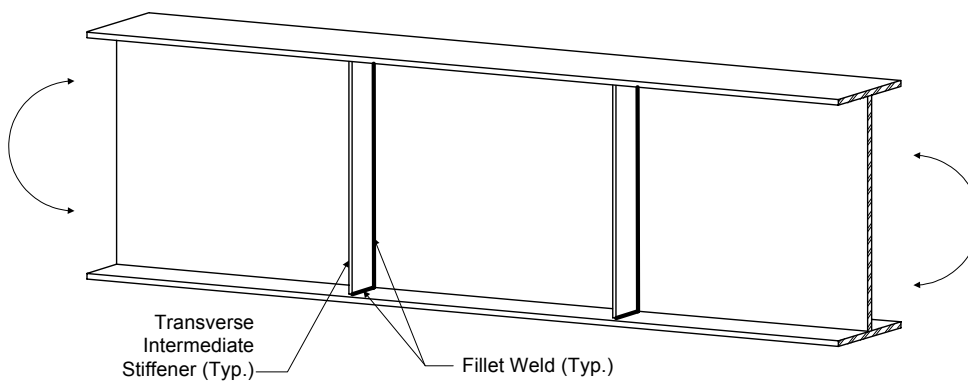

Figure 3-10 Load-Induced Fatigue Detail

The nominal fatigue resistance is computed as follows:

$$(\Delta F)_n = \left(\frac{A}{N}\right)^{\frac{1}{3}} \geq \frac{1}{2}(\Delta F)_{TH}$$

for which:

$$A = 44.0 \cdot 10^8 \text{ (ksi)}^3$$

$$N = (365) \cdot (75) \cdot n \cdot (ADTT)_{SL}$$

$$n = 1.0$$

$$ADTT_{SL} = 3000$$

S6.6.1.2.5

*S*Table
6.6.1.2.5-1

S6.6.1.2.5

*S*Table
6.6.1.2.5-2

$$N = (365) \cdot (75) \cdot n \cdot ADTT_{SL}$$

$$N = 82125000$$

$$\Delta F_{TH} = 12.0 \cdot \text{ksi}$$

$$\left(\frac{A}{N}\right)^{\frac{1}{3}} = 3.77 \text{ ksi}$$

$$\frac{1}{2} \cdot \Delta F_{TH} = 6.00 \text{ ksi}$$

$$\Delta F_n = \max \left[\left(\frac{A}{N}\right)^{\frac{1}{3}}, \frac{1}{2} \cdot \Delta F_{TH} \right]$$

$$\Delta F_n = 6.00 \text{ ksi}$$

*S*Table
6.6.1.2.5-3

S6.6.1.2.5



Fatigue Resistance

*C*Table 6.6.1.2.5-1 can be used to eliminate the need for some of the above fatigue resistance computations. The above computations are presented simply for illustrative purposes.

The factored fatigue stress in the outer fiber of the tension flange at the location of maximum positive moment was previously computed in Table 3-11, as follows:

$$f_{botgdr} = 3.87 \cdot \text{ksi}$$

$$f_{botgdr} \leq \Delta F_n \quad \text{OK}$$

In addition to the above fatigue detail check, fatigue requirements for webs must also be checked. These calculations will be presented later for the girder design section at the pier.

S6.10.6

Design Step 3.15 - Design for Flexure - Service Limit State - Positive Moment Region

The girder must be checked for service limit state control of permanent deflection. This check is intended to prevent objectionable permanent deflections due to expected severe traffic loadings that would impair rideability. Service II Limit State is used for this check.

S6.10.5

The flange stresses for both steel flanges of composite sections must satisfy the following requirement:

$$f_f \leq 0.95F_{yf}$$

S6.10.5.2

The factored Service II flexural stress was previously computed in Table 3-11 as follows:

$$f_{\text{botgdr}} = 44.00 \cdot \text{ksi}$$

$$f_{\text{topgdr}} = -23.06 \cdot \text{ksi}$$

$$F_{yf} = 50.0 \text{ ksi}$$

$$0.95 \cdot F_{yf} = 47.50 \text{ ksi} \quad \text{OK}$$

In addition to the check for service limit state control of permanent deflection, the girder can also be checked for live load deflection. Although this check is optional for a concrete deck on steel girders, it is included in this design example.

S2.5.2.6.2

Using an analysis computer program, the maximum live load deflection is computed to be the following:

$$\Delta_{\text{max}} = 1.43 \cdot \text{in}$$

This maximum live load deflection is computed based on the following:

S2.5.2.6.2

1. All design lanes are loaded.
2. All supporting components are assumed to deflect equally.
3. For composite design, the design cross section includes the entire width of the roadway.
4. The number and position of loaded lanes is selected to provide the worst effect.
5. The live load portion of Service I Limit State is used.
6. Dynamic load allowance is included.
7. The live load is taken from S3.6.1.3.2.

In the absence of other criteria, the deflection limit is as follows:

$$\text{Span} = 120 \cdot \text{ft}$$

$$\Delta_{\text{allowable}} = \left(\frac{\text{Span}}{800} \right) \cdot \left(\frac{12 \text{in}}{\text{ft}} \right)$$

$$\Delta_{\text{allowable}} = 1.80 \text{in} \quad \text{OK}$$

S2.5.2.6.2

Design Step 3.16 - Design for Flexure - Constructibility Check - Positive Moment Region

The girder must also be checked for flexure during construction. The girder has already been checked in its final condition when it behaves as a composite section. The constructibility must also be checked for the girder prior to the hardening of the concrete deck when the girder behaves as a noncomposite section.

S6.10.3.2

As previously stated, a deck pouring sequence will not be considered in this design example. However, it is generally important to consider the effects of the deck pouring sequence in an actual design because it will often control the design of the top flange in the positive moment regions of composite girders.

The investigation of the constructibility of the girder begins with the the noncompact section compression-flange slenderness check, as follows:

S6.10.4.1.4

$$\frac{b_f}{2 \cdot t_f} \leq 12.0$$

$$b_f = 14 \text{in} \quad (\text{see Figure 3-4})$$

$$t_f = 0.625 \text{in} \quad (\text{see Figure 3-4})$$

$$\frac{b_f}{2 \cdot t_f} = 11.2$$

Therefore, the investigation proceeds with the noncompact section compression-flange bracing provisions of S6.10.4.1.9.

$$L_b \leq L_p = 1.76 \cdot r_t \cdot \sqrt{\frac{E}{F_{yc}}}$$

S6.10.4.1.9

The term, r_t , is defined as the radius of gyration of a notional section comprised of the compression flange of the steel section plus one-third of the depth of the web in compression taken about the vertical axis.

For the noncomposite loads during construction:

$$\text{Depth}_{\text{comp}} = 55.50 \cdot \text{in} - 25.852 \cdot \text{in}$$

(see Figure 3-4 and Table 3-4)

$$\text{Depth}_{\text{comp}} = 29.65 \text{ in}$$

$$D_c = \text{Depth}_{\text{comp}} - t_{\text{topfl}}$$

$$D_c = 29.02 \text{ in} \qquad \frac{D_c}{3} = 9.67 \text{ in}$$

$$b_c = 14.0 \text{ in} \qquad t_c = 0.625 \text{ in}$$

$$I_t = \frac{t_c \cdot b_c^3}{12} + \frac{\frac{D_c}{3} \cdot t_w^3}{12} \qquad I_t = 143.0 \text{ in}^4$$

$$A_t = (t_c \cdot b_c) + \left(\frac{D_c}{3} \cdot t_w \right) \qquad A_t = 13.6 \text{ in}^2$$

$$r_t = \sqrt{\frac{I_t}{A_t}} \qquad r_t = 3.24 \text{ in}$$

$$E = 29000 \text{ ksi} \qquad F_{yc} = 50 \text{ ksi}$$

$$L_p = 1.76 \cdot r_t \cdot \sqrt{\frac{E}{F_{yc}}} \qquad L_p = 11.46 \text{ ft}$$

$$L_b = 20.0 \text{ ft}$$

Therefore, the investigation proceeds with the noncomposite section lateral torsional buckling provisions of S6.10.4.2.6.



Lateral Torsional Buckling

Lateral torsional buckling can occur when the compression flange is not laterally supported. The laterally unsupported compression flange tends to buckle out-of-plane between the points of lateral support. Because the tension flange is kept in line, the girder section twists when it moves laterally. This behavior is commonly referred to as lateral torsional buckling.

Lateral torsional buckling is generally most critical for the moments induced during the deck pouring sequence.

If lateral torsional buckling occurs, the plastic moment resistance, M_p , can not be reached.

Lateral torsional buckling is illustrated in the figure below.

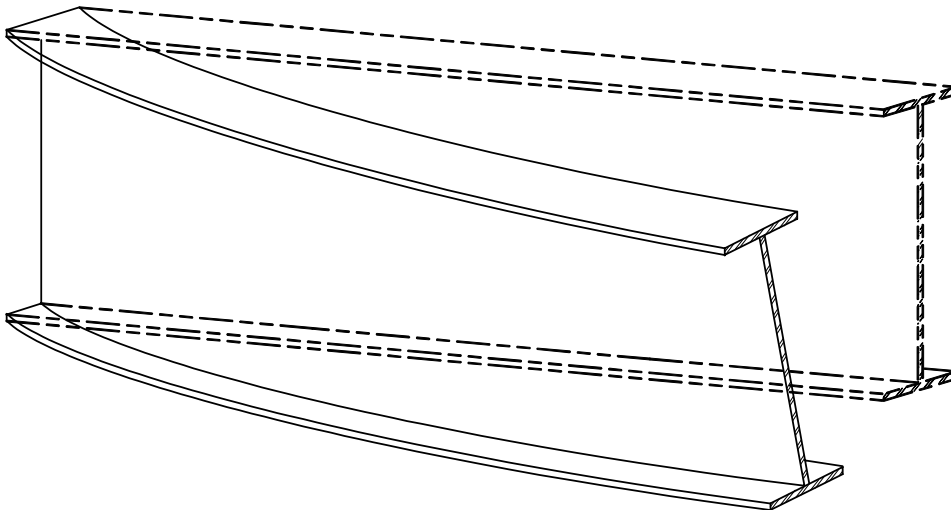

Figure 3-11 Lateral Torsional Buckling

The nominal flexural resistance of the compression flange is determined from the following equation:

$$F_n = R_b \cdot R_h \cdot F_{cr}$$

The load-shedding factor, R_b , is computed as follows:

S6.10.4.2.6a

S6.10.4.2.4a

S6.10.4.3.2

$\lambda_b = 4.64$ for sections where D_c is greater than $D/2$

$$D_c = 29.02 \text{ in}$$

$$D = 54.0 \text{ in}$$

$$\frac{D}{2} = 27.00 \text{ in}$$

Therefore $\lambda_b = 4.64$

Check if
$$\frac{2 \cdot D_c}{t_w} \leq \lambda_b \cdot \sqrt{\frac{E}{f_c}}$$

$$D_c = 29.02 \text{ in}$$

$$t_w = 0.50 \text{ in}$$

$$\frac{2 \cdot D_c}{t_w} = 116.1$$

$$E = 29000 \text{ ksi}$$

$$f_c = 1.25 \cdot (19.44 \cdot \text{ksi})$$

$$f_c = 24.30 \text{ ksi}$$

$$\lambda_b \cdot \sqrt{\frac{E}{f_c}} = 160.3$$

Therefore: $R_b = 1.0$

For homogeneous section, R_h is taken as 1.0.

$$R_h = 1.0$$

The critical compression-flange local buckling stress, F_{cr} , is computed as follows:

$$F_{cr} = \frac{1.904 \cdot E}{\left(\frac{b_f}{2 \cdot t_f}\right)^2 \cdot \sqrt{\frac{2 \cdot D_c}{t_w}}} \leq F_{yc} \quad \text{without longitudinal web stiffeners}$$

$$\frac{1.904 \cdot E}{\left(\frac{b_f}{2 \cdot t_f}\right)^2 \cdot \sqrt{\frac{2 \cdot D_c}{t_w}}} = 40.9 \text{ ksi} \quad F_{yc} = 50.0 \text{ ksi}$$

S6.10.4.3.1

S6.10.4.2.4a

$$F_{cr} = \min \left[\frac{1.904 \cdot E}{\left(\frac{b_f}{2 \cdot t_f} \right)^2 \cdot \sqrt{\frac{2 \cdot D_c}{t_w}}}, F_{yc} \right] \quad F_{cr} = 40.9 \text{ ksi}$$

Therefore the nominal flexural resistance of the compression flange is determined from the following equation:

$$F_n = R_b \cdot R_h \cdot F_{cr}$$

$$F_n = 40.9 \text{ ksi}$$

In addition, the nominal flexural resistance of the compression flange should not exceed the nominal flexural resistance based upon lateral-torsional buckling determined as follows:

$$\text{Check if } \frac{2 \cdot D_c}{t_w} \leq \lambda_b \cdot \sqrt{\frac{E}{F_{yc}}}$$

$$D_c = 29.02 \text{ in} \quad t_w = 0.5 \text{ in}$$

$$\frac{2 \cdot D_c}{t_w} = 116.1$$

$$\lambda_b = 4.64 \quad E = 29000 \text{ ksi} \quad F_{yc} = 50.0 \text{ ksi}$$

$$\lambda_b \cdot \sqrt{\frac{E}{F_{yc}}} = 111.7$$

$$\text{Check if } L_b \leq L_r = 4.44 \cdot \sqrt{\frac{I_{yc} \cdot d}{S_{xc}} \cdot \frac{E}{F_{yc}}}$$

$$I_{yc} = 142.9 \text{ in}^4$$

$$d = 55.50 \text{ in}$$

$$S_{xc} = 745.9 \text{ in}^3 \quad (\text{see Table 3-4})$$

$$E = 29000.0 \text{ ksi}$$

$$F_{yc} = 50.0 \text{ ksi}$$

$$L_r = 4.44 \cdot \sqrt{\frac{I_{yc} \cdot d}{S_{xc}} \cdot \frac{E}{F_{yc}}} \quad L_r = 29.06 \text{ ft}$$

S6.10.4.2.4a

S6.10.4.2.6a

$$L_b = 20.0 \text{ ft}$$

Therefore:

$$M_n = C_b \cdot R_b \cdot R_h \cdot M_y \cdot \left[1 - 0.5 \left(\frac{L_b - L_p}{L_r - L_p} \right) \right] \leq R_b \cdot R_h \cdot M_y$$

S6.10.4.2.6a

The moment gradient correction factor, C_b , is computed as follows:

S6.10.4.2.5a

$$C_b = 1.75 - 1.05 \cdot \left(\frac{P_l}{P_h} \right) + 0.3 \cdot \left(\frac{P_l}{P_h} \right)^2 \leq K_b$$

$$\text{Use: } \frac{P_l}{P_h} = 0.5 \quad (\text{based on analysis})$$

$$1.75 - 1.05 \cdot (0.5) + 0.3 \cdot (0.5)^2 = 1.30$$

$$K_b = 1.75$$

$$\text{Therefore } C_b = 1.30$$

$$M_y = (50 \cdot \text{ksi}) \cdot 745.98 \cdot \text{in}^3 \qquad M_y = 3108 \text{ K} \cdot \text{ft}$$

S6.10.3.3.1

$$I_t = \frac{t_c \cdot b_c^3}{12} \qquad I_t = 142.9 \text{ in}^4$$

S6.10.4.2.6a

$$A_t = t_c \cdot b_c \qquad A_t = 8.8 \text{ in}^2$$

$$r_t = \sqrt{\frac{I_t}{A_t}} \qquad r_t = 4.04 \text{ in}$$

$$E = 29000 \text{ ksi} \qquad F_{yc} = 50 \text{ ksi}$$

$$L_p = 1.76 \cdot r_t \cdot \sqrt{\frac{E}{F_{yc}}} \qquad L_p = 14.28 \text{ ft}$$

$$L_b = 20.0 \text{ ft} \qquad L_r = 29.06 \text{ ft}$$

$$C_b \cdot R_b \cdot R_h \cdot M_y \cdot \left[1 - 0.5 \cdot \left(\frac{L_b - L_p}{L_r - L_p} \right) \right] = 3258 \text{ K} \cdot \text{ft}$$

$$R_b \cdot R_h \cdot M_y = 3108 \text{ K} \cdot \text{ft}$$

$$\text{Therefore } M_n = R_b \cdot R_h \cdot M_y \quad M_n = 3108 \text{ K}\cdot\text{ft}$$

S6.10.4.2.6a

$$F_n = \frac{M_n}{S_{xc}} \quad F_n = 50.0 \text{ ksi}$$

Therefore, the provisions of *SEquation 6.10.4.2.4a-2* control.

$$F_n = R_b \cdot R_h \cdot F_{cr} \quad F_n = 40.9 \text{ ksi}$$

The factored flexural resistance, F_r , is computed as follows:

S6.10.4

$$\phi_f = 1.00$$

S6.5.4.2

$$F_r = \phi_f \cdot F_n \quad F_r = 40.9 \text{ ksi}$$

The factored construction stress in the compression flange is as follows:

$$f_c = 24.30 \text{ ksi} \quad (\text{previously computed}) \quad \text{OK}$$

For the tension flange, the nominal flexural resistance, in terms of stress, is determined as follows:

S6.10.4.2.6b

$$F_n = R_b \cdot R_h \cdot F_{yt}$$

$$\text{where: } R_b = 1.0$$

S6.10.4.3.2b

$$R_h = 1.0$$

$$F_{yt} = 50.0 \text{ ksi}$$

$$F_n = 50.0 \text{ ksi}$$

The factored flexural resistance, F_r , is computed as follows:

S6.10.4

$$\phi_f = 1.00$$

S6.5.4.2

$$F_r = \phi_f \cdot F_n$$

$$F_r = 50.0 \text{ ksi}$$

The factored construction stress in the tension flange is as follows:

$$f_t = 1.25 \cdot (16.95 \cdot \text{ksi})$$

$$f_t = 21.19 \text{ ksi} \quad \text{OK}$$

Therefore, the girder design section at the location of maximum positive moment satisfies the noncomposite section flexural resistance requirements for construction loads based upon lateral torsional buckling for both the compression flange and the tension flange.

In addition, composite girders, when they are not yet composite, must satisfy the following requirement during construction:

S6.10.3.2.2

$$f_{cw} \leq \frac{0.9 \cdot E \cdot \alpha \cdot k}{\left(\frac{D}{t_w}\right)^2} \leq F_{yw}$$

for which:

$$E = 29000 \text{ ksi}$$

$$\alpha = 1.25 \quad \text{for webs without longitudinal stiffeners}$$

$$D = 54 \text{ in}$$

$$D_c = 29.02 \text{ in}$$

$$k = 9.0 \cdot \left(\frac{D}{D_c}\right)^2 \geq 7.2 \quad \text{for webs without longitudinal stiffeners}$$

$$9.0 \cdot \left(\frac{D}{D_c}\right)^2 = 31.2$$

$$k = \max \left[9.0 \cdot \left(\frac{D}{D_c}\right)^2, 7.2 \right] \quad k = 31.2$$

$$t_w = \frac{1}{2} \text{ in} \quad \text{(see Figure 3-4)}$$

$$\frac{0.9 \cdot E \cdot \alpha \cdot k}{\left(\frac{D}{t_w}\right)^2} = 87.15 \text{ ksi}$$

$$F_{yw} = 50.0 \text{ ksi}$$

$$\min \left[\frac{0.9 \cdot E \cdot \alpha \cdot k}{\left(\frac{D}{t_w}\right)^2}, F_{yw} \right] = 50.0 \text{ ksi}$$

$$f_{cw} = f_{topgdr} \cdot \left(\frac{D_c}{D_c + t_f} \right)$$

$$f_{cw} = -22.57 \text{ ksi} \quad \text{OK}$$

In addition to checking the nominal flexural resistance during construction, the nominal shear resistance must also be checked. However, shear is minimal at the location of maximum positive moment, and it is maximum at the pier.

S6.10.3.2.3

Therefore, for this design example, the nominal shear resistance for constructibility will be presented later for the girder design section at the pier.

Design Step 3.17 - Check Wind Effects on Girder Flanges - Positive Moment Region

As stated in Design Step 3.3, for this design example, the interior girder controls and is being designed.

S6.10.3.5

Wind effects generally do not control a steel girder design, and they are generally considered for the exterior girders only. However, for this design example, wind effects will be presented later for the girder design section at the pier.

C6.10.3.5.2 &
C4.6.2.7.1

Specification checks have been completed for the location of maximum positive moment, which is at 0.4L in Span 1.

Now the specification checks are repeated for the location of maximum negative moment, which is at the pier, as shown in Figure 3-12. This is also the location of maximum shear.

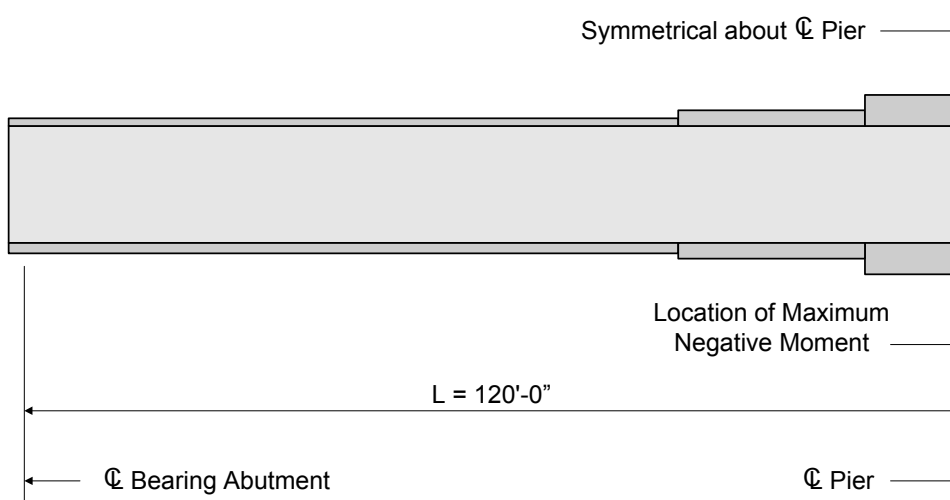

Figure 3-12 Location of Maximum Negative Moment

Design Step 3.7 - Check Section Proportion Limits - Negative Moment Region

Several checks are required to ensure that the proportions of the trial girder section are within specified limits.

S6.10.2

The first section proportion check relates to the general proportions of the section. The flexural components must be proportioned such that:

S6.10.2.1

$$0.1 \leq \frac{I_{yc}}{I_y} \leq 0.9$$

$$I_{yc} = \frac{2.75 \cdot \text{in} \cdot (14 \cdot \text{in})^3}{12} \quad I_{yc} = 628.8 \text{ in}^4$$

$$I_y = \frac{2.75 \cdot \text{in} \cdot (14 \cdot \text{in})^3}{12} + \frac{54 \cdot \text{in} \cdot \left(\frac{1}{2} \cdot \text{in}\right)^3}{12} + \frac{2.5 \cdot \text{in} \cdot (14 \cdot \text{in})^3}{12}$$

$$I_y = 1201.1 \text{ in}^4$$

$$\frac{I_{yc}}{I_y} = 0.524 \quad \text{OK}$$

The second section proportion check relates to the web slenderness. For a section without longitudinal stiffeners, the web must be proportioned such that:

$$\frac{2 \cdot D_c}{t_w} \leq 6.77 \cdot \sqrt{\frac{E}{f_c}} \leq 200$$

At sections in negative flexure, using D_c of the composite section consisting of the steel section plus the longitudinal reinforcement is conservative.

S6.10.2.2

C6.10.3.1.4a



D_c for Negative Flexure

At sections in negative flexure, using D_c of the composite section consisting of the steel section plus the longitudinal reinforcement, as described in C6.10.3.1.4a, removes the dependency of D_c on the applied loading, which greatly simplifies subsequent load rating calculations.

$$D_c = 32.668 \cdot \text{in} - 2.75 \cdot \text{in}$$

(see Figure 3-4 and Table 3-5)

$$D_c = 29.92 \text{ in}$$

$$t_w = \frac{1}{2} \text{ in} \quad (\text{see Figure 3-4})$$

$$E = 29000 \text{ ksi}$$

$$f_c = 48.84 \cdot \text{ksi}$$

$$\frac{2 \cdot D_c}{t_w} = 119.7$$

$$6.77 \cdot \sqrt{\frac{E}{f_c}} = 165.0$$

$$\frac{2 \cdot D_c}{t_w} \leq 6.77 \cdot \sqrt{\frac{E}{f_c}} \quad \text{and} \quad \frac{2 \cdot D_c}{t_w} \leq 200 \quad \text{OK}$$

S6.4.1

The third section proportion check relates to the flange proportions. The compression flanges on fabricated I-sections must be proportioned such that:

$$b_f \geq 0.3 \cdot D_c$$

$$b_f = 14 \text{ in} \quad (\text{see Figure 3-4})$$

$$D_c = 29.92 \text{ in}$$

$$0.3 \cdot D_c = 8.98 \text{ in}$$

$$b_f \geq 0.3 \cdot D_c \quad \text{OK}$$

S6.10.2.3

According to C6.10.2.3, it is preferable for the flange width to be greater than or equal to $0.4D_c$. In this case, the flange width is greater than both $0.3D_c$ and $0.4D_c$, so this requirement is clearly satisfied.

C6.10.2.3

In addition to the compression flange check, the tension flanges on fabricated I-sections must be proportioned such that:

S6.10.2.3

$$\frac{b_t}{2 \cdot t_t} \leq 12.0$$

$$b_t = 14 \text{ in} \quad (\text{see Figure 3-4})$$

$$t_t = 2.5 \text{ in} \quad (\text{see Figure 3-4})$$

$$\frac{b_t}{2 \cdot t_t} = 2.8 \quad \text{OK}$$

**Design Step 3.8 - Compute Plastic Moment Capacity - Negative
Moment Region**

For composite sections, the plastic moment, M_p , is calculated as the first moment of plastic forces about the plastic neutral axis.

S6.10.3.1.3

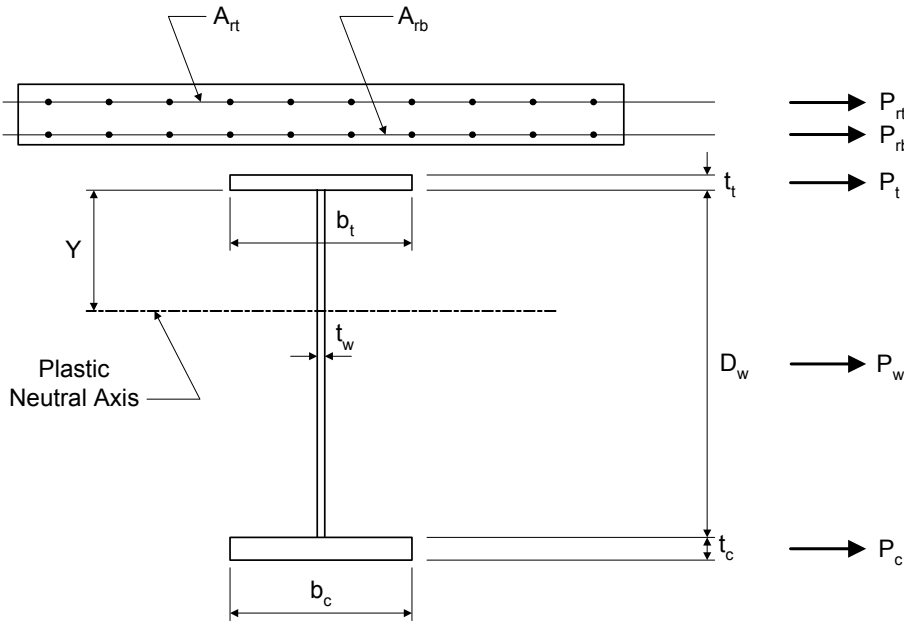

Figure 3-13 Computation of Plastic Moment Capacity for Negative Bending Sections

For the tension flange:

$$F_{yt} = 50\text{ksi} \quad b_t = 14\text{in} \quad t_t = 2.50\text{in}$$

$$P_t = F_{yt} \cdot b_t \cdot t_t \quad P_t = 1750\text{K}$$

For the web:

$$F_{yw} = 50.0\text{ksi} \quad D_w = 54\text{in} \quad t_w = 0.50\text{in}$$

$$P_w = F_{yw} \cdot D_w \cdot t_w \quad P_w = 1350\text{K}$$

For the compression flange:

$$F_{yc} = 50\text{ksi} \quad b_c = 14\text{in} \quad t_c = 2.75\text{in}$$

$$P_c = F_{yc} \cdot b_c \cdot t_c \quad P_c = 1925\text{K}$$

For the longitudinal reinforcing steel in the top layer of the slab at the pier:

$$F_{yrt} = 60\text{ksi}$$

SAppendix A6.1

$$A_{rt} = 0.31 \cdot \text{in}^2 \cdot \left(\frac{103 \cdot \text{in}}{5 \text{in}} \right) \quad A_{rt} = 6.39 \text{in}^2$$

$$P_{rt} = F_{yt} \cdot A_{rt} \quad P_{rt} = 383 \text{K}$$

For the longitudinal reinforcing steel in the bottom layer of the slab at the pier:

$$F_{yrb} = 60 \text{ksi}$$

$$A_{rb} = 0.31 \cdot \text{in}^2 \cdot \left(\frac{103 \text{in}}{5 \text{in}} \right) \quad A_{rb} = 6.39 \text{in}^2$$

$$P_{rb} = F_{yrb} \cdot A_{rb} \quad P_{rb} = 383 \text{K}$$

Check the location of the plastic neutral axis, as follows:

$$P_c + P_w = 3275 \text{K} \quad P_t + P_{rb} + P_{rt} = 2516 \text{K}$$

$$P_c + P_w + P_t = 5025 \text{K} \quad P_{rb} + P_{rt} = 766 \text{K}$$

Therefore the plastic neutral axis is located within the web.

$$Y = \left(\frac{D}{2} \right) \cdot \left(\frac{P_c - P_t - P_{rt} - P_{rb}}{P_w} + 1 \right)$$

$$Y = 15.17 \text{in}$$

Since it will be shown in the next design step that this section is noncompact, the plastic moment is not used to compute the flexural resistance and therefore does not need to be computed.

Design Step 3.9 - Determine if Section is Compact or Noncompact - Negative Moment Region

The next step in the design process is to determine if the section is compact or noncompact. This, in turn, will determine which formulae should be used to compute the flexural capacity of the girder.

Where the specified minimum yield strength does not exceed 70.0 ksi, and the girder has a constant depth, and the girder does not have longitudinal stiffeners or holes in the tension flange, then the first step is to check the compact-section web slenderness provisions, as follows:

SAppendix A6.1

*S*Table A6.1-2

S6.10.4.1.1

$$\frac{2 \cdot D_{cp}}{t_w} \leq 3.76 \cdot \sqrt{\frac{E}{F_{yc}}}$$

S6.10.4.1.2

Since the plastic neutral axis is located within the web,

$$D_{cp} = D_w - Y$$

$$D_{cp} = 38.83 \text{ in}$$

$$\frac{2 \cdot D_{cp}}{t_w} = 155.3$$

$$3.76 \cdot \sqrt{\frac{E}{F_{yc}}} = 90.6$$

Therefore, the web does not qualify as compact. Since this is not a composite section in positive flexure, the investigation proceeds with the noncompact section compression-flange slenderness provisions of S6.10.4.1.4.

$$\frac{b_f}{2 \cdot t_f} \leq 12.0$$

S6.10.4.1.4

$$b_f = 14.0 \text{ in}$$

$$t_f = 2.75 \text{ in}$$

$$\frac{b_f}{2 \cdot t_f} = 2.5$$

Therefore, the investigation proceeds with the noncompact section compression-flange bracing provisions of S6.10.4.1.9.

$$L_b \leq L_p = 1.76 \cdot r_t \cdot \sqrt{\frac{E}{F_{yc}}}$$

S6.10.4.1.9

The term, r_t , is defined as the radius of gyration of a notional section comprised of the compression flange of the steel section plus one-third of the depth of the web in compression taken about the vertical axis.

Based on previous computations,

$$D_c = 29.92 \text{ in}$$

$$\frac{D_c}{3} = 9.97 \text{ in}$$

$$b_c = 14.0 \text{ in}$$

$$t_c = 2.75 \text{ in}$$

$$I_t = \frac{t_c \cdot b_c^3}{12} + \frac{\frac{D_c}{3} \cdot t_w^3}{12}$$

$$I_t = 628.9 \text{ in}^4$$

$$A_t = (t_c \cdot b_c) + \left(\frac{D_c}{3} \cdot t_w \right) \quad A_t = 43.5 \text{ in}^2$$

$$r_t = \sqrt{\frac{I_t}{A_t}} \quad r_t = 3.80 \text{ in}$$

$$L_p = 1.76 \cdot r_t \cdot \sqrt{\frac{E}{F_{yc}}} \quad L_p = 13.43 \text{ ft}$$

$$L_b = 20.0 \text{ ft}$$

Therefore, the investigation proceeds with the composite section lateral torsional buckling provisions of S6.10.4.2.5.



Noncompact Sections

Based on the previous computations, it was determined that the girder section at the pier is noncompact. Several steps could be taken to make this a compact section, such as increasing the web thickness or possibly modifying the flange thicknesses to decrease the value D_{cp} . However, such revisions may not be economical.

Design Step 3.10 - Design for Flexure - Strength Limit State - Negative Moment Region

Since the section was determined to be noncompact and based on the computations in the previous design step, the nominal flexural resistance is computed based upon lateral torsional buckling.

S6.10.4.2.5

The nominal flexural resistance of the compression flange, in terms of stress, is determined from the following equation:

S6.10.4.2.5a

$$F_n = R_b \cdot R_h \cdot F_{cr}$$

S6.10.4.2.4a

The load-shedding factor, R_b , is computed as follows:

S6.10.4.3.2

$$\lambda_b = 4.64 \quad \text{for sections where } D_c \text{ is greater than } D/2$$

$$D_c = 29.92 \text{ in} \quad f_c = 48.84 \text{ ksi}$$

$$D = 54.0 \text{ in} \quad \frac{D}{2} = 27.00 \text{ in}$$

Therefore $\lambda_b = 4.64$

Check if $\frac{2 \cdot D_c}{t_w} \leq \lambda_b \cdot \sqrt{\frac{E}{f_c}}$

$$D_c = 29.92 \text{ in} \quad t_w = 0.50 \text{ in}$$

$$\frac{2 \cdot D_c}{t_w} = 119.7$$

$$\lambda_b \cdot \sqrt{\frac{E}{f_c}} = 113.1$$

Therefore: $R_b = 1.0$

For homogeneous section, R_h is taken as 1.0.

$$R_h = 1.0$$

The critical compression-flange local buckling stress, F_{cr} , is computed as follows:

$$F_{cr} = \frac{1.904 \cdot E}{\left(\frac{b_f}{2 \cdot t_f}\right)^2 \cdot \sqrt{\frac{2 \cdot D_c}{t_w}}} \leq F_{yc} \quad \text{without longitudinal web stiffeners}$$

$$\frac{1.904 \cdot E}{\left(\frac{b_f}{2 \cdot t_f}\right)^2 \cdot \sqrt{\frac{2 \cdot D_c}{t_w}}} = 779.0 \text{ ksi} \quad F_{yc} = 50.0 \text{ ksi}$$

$$F_{cr} = \min \left[\frac{1.904 \cdot E}{\left(\frac{b_f}{2 \cdot t_f}\right)^2 \cdot \sqrt{\frac{2 \cdot D_c}{t_w}}}, F_{yc} \right] \quad F_{cr} = 50.0 \text{ ksi}$$

Therefore the nominal flexural resistance of the compression flange is determined from the following equation:

$$F_n = R_b \cdot R_h \cdot F_{cr}$$

$$F_n = 50.0 \text{ ksi}$$

S6.10.4.3.1

S6.10.4.2.4a

S6.10.4.2.4a

In addition, the nominal flexural resistance of the compression flange should not exceed the nominal flexural resistance based upon lateral-torsional buckling determined as follows:

S6.10.4.2.5a

$$\text{Check if } L_b \leq L_r = 4.44 \cdot r_t \cdot \sqrt{\frac{E}{F_{yc}}}$$

$$L_r = 4.44 \cdot r_t \cdot \sqrt{\frac{E}{F_{yc}}}$$

$$r_t = 3.80 \text{ in} \quad E = 29000 \text{ ksi} \quad F_{yc} = 50.0 \text{ ksi}$$

$$L_r = 33.9 \text{ ft} \quad L_b = 20 \text{ ft}$$

Therefore:

$$F_n = C_b \cdot R_b \cdot R_h \cdot F_{yc} \cdot \left[1.33 - 0.187 \left(\frac{L_b}{r_t} \right) \cdot \sqrt{\frac{F_{yc}}{E}} \right] \leq R_b \cdot R_h \cdot F_{yc}$$

The moment gradient correction factor, C_b , is computed as follows:

SC6.10.4.2.5a

$$C_b = 1.75 - 1.05 \cdot \left(\frac{P_l}{P_h} \right) + 0.3 \cdot \left(\frac{P_l}{P_h} \right)^2 \leq K_b$$

$$\text{Use: } \frac{P_l}{P_h} = 0.5 \quad (\text{based on analysis})$$

$$1.75 - 1.05 \cdot (0.5) + 0.3 \cdot (0.5)^2 = 1.30$$

$$K_b = 1.75$$

$$\text{Therefore } C_b = 1.30$$

$$C_b \cdot R_b \cdot R_h \cdot F_{yc} \cdot \left[1.33 - 0.187 \left[\frac{L_b \cdot \left(\frac{12 \text{ in}}{\text{ft}} \right)}{r_t} \right] \cdot \sqrt{\frac{F_{yc}}{E}} \right] = 54.60 \text{ ksi}$$

$$R_b \cdot R_h \cdot F_{yc} = 50.0 \text{ ksi}$$

$$\text{Therefore } F_n = R_b \cdot R_h \cdot F_{yc}$$

$$F_n = 50.0 \text{ ksi}$$

The factored flexural resistance, F_r , is computed as follows:

$$\phi_f = 1.00$$

$$F_r = \phi_f \cdot F_n$$

$$F_r = 50.0 \text{ ksi}$$

The negative flexural resistance at this design section is checked as follows:

$$\sum \eta_i \cdot \gamma_i \cdot Q_i \leq R_r$$

or in this case:

$$\sum \eta_i \cdot \gamma_i \cdot F_i \leq F_r$$

For this design example,

$$\eta_i = 1.00$$

As computed in Design Step 3.6, the factored Strength I Limit State stress for the compression flange is as follows:

$$\sum \gamma_i \cdot F_i = 48.84 \text{ ksi}$$

Therefore $\sum \eta_i \cdot \gamma_i \cdot F_i = 48.84 \cdot \text{ksi}$

$$F_r = 50.00 \text{ ksi} \quad \text{OK}$$

For the tension flange, the nominal flexural resistance, in terms of stress, is determined as follows:

$$F_n = R_b \cdot R_h \cdot F_{yt}$$

where: $R_b = 1.0$

$$R_h = 1.0$$

$$F_{yt} = 50.0 \text{ ksi}$$

$$F_n = 50.0 \text{ ksi}$$

The factored flexural resistance, F_r , is computed as follows:

$$\phi_f = 1.00$$

$$F_r = \phi_f \cdot F_n$$

$$F_r = 50.0 \text{ ksi}$$

S6.10.4

S6.5.4.2

S1.3.2.1

S6.10.4.2.5b

S6.10.4.3.2b

S6.10.4

S6.5.4.2

The negative flexural resistance at this design section is checked as follows:

$$\sum \eta_i \cdot \gamma_i \cdot Q_i \leq R_r$$

or in this case:

$$\sum \eta_i \cdot \gamma_i \cdot F_i \leq F_r$$

For this design example,

$$\eta_i = 1.00$$

As computed in Design Step 3.6, the factored Strength I Limit State stress for the tension flange is as follows:

$$\sum \gamma_i \cdot F_i = 44.99 \text{ ksi}$$

Therefore $\sum \eta_i \cdot \gamma_i \cdot F_i = 44.99 \cdot \text{ksi}$

$$F_r = 50.0 \text{ ksi} \quad \text{OK}$$

Therefore, the girder design section at the pier satisfies the flexural resistance requirements for both the compression flange and the tension flange.

Design Step 3.11 - Design for Shear - Negative Moment Region

Shear must be checked at each section of the girder. For this design example, shear is maximum at the pier.

The first step in the design for shear is to check if the web must be stiffened. The nominal shear resistance of unstiffened webs of hybrid and homogeneous girders is:

$$V_n = C \cdot V_p$$

$$k = 5.0$$

$$\frac{D}{t_w} = 108.0$$

$$1.10 \cdot \sqrt{\frac{E \cdot k}{F_{yw}}} = 59.2$$

S1.3.2.1

S6.10.7

S6.10.7.2

S6.10.7.3.3a

S6.10.7.3.3a

$$1.38 \cdot \sqrt{\frac{E \cdot k}{F_{yw}}} = 74.3$$

$$\text{Therefore, } \frac{D}{t_w} \geq 1.38 \cdot \sqrt{\frac{E \cdot k}{F_{yw}}}$$

$$C = \frac{1.52}{\left(\frac{D}{t_w}\right)^2} \cdot \left(\frac{E \cdot k}{F_{yw}}\right)$$

$$C = 0.378$$

$$F_{yw} = 50.0 \text{ ksi} \quad D = 54.0 \text{ in} \quad t_w = 0.5 \text{ in}$$

$$V_p = 0.58 \cdot F_{yw} \cdot D \cdot t_w$$

$$V_p = 783.0 \text{ K}$$

$$V_n = C \cdot V_p$$

$$V_n = 295.9 \text{ K}$$

S6.10.7.3.3a&c

The factored shear resistance, V_r , is computed as follows:

S6.10.7.1

$$\phi_v = 1.00$$

S6.5.4.2

$$V_r = \phi_v \cdot V_n$$

$$V_r = 295.9 \text{ K}$$

The shear resistance at this design section is checked as follows:

S1.3.2.1

$$\sum \eta_i \cdot \gamma_i \cdot Q_i \leq R_r$$

or in this case:

$$\sum \eta_i \cdot \gamma_i \cdot V_i \leq V_r$$

For this design example,

$$\eta_i = 1.00$$

As computed in Design Step 3.6, the factored Strength I Limit State shear is as follows:

$$\sum \gamma_i \cdot V_i = 423.5 \cdot \text{K}$$

Therefore $\Sigma \eta_i \cdot \gamma_i \cdot V_i = 423.5 \cdot K$

$$V_r = 295.9K$$

Since the shear resistance of an unstiffened web is less than the actual design shear, the web must be stiffened.



Nominally Stiffened Webs

As previously explained, a "nominally stiffened" web (approximately 1/16 inch thinner than "unstiffened") will generally provide the least cost alternative or very close to it. However, for web depths of approximately 50 inches or less, unstiffened webs may be more economical.

For this design example, transverse intermediate stiffeners are used and longitudinal stiffeners are not used. The transverse intermediate stiffener spacing in this design example is 80 inches. Therefore, the spacing of the transverse intermediate stiffeners does not exceed 3D. Therefore, the design section can be considered stiffened and the provisions of S6.10.7.3 apply.

S6.10.7.1



Stiffener Spacing

The spacing of the transverse intermediate stiffeners is determined such that it satisfies all spacing requirement in S6.10.7 and such that the shear resistance of the stiffened web is sufficient to resist the applied factored shear.

First, handling requirements of the web are checked. For web panels without longitudinal stiffeners, transverse stiffeners must be used if:

S6.10.7.3.2

$$\frac{D}{t_w} \geq 150$$

$$D = 54.0 \text{ in} \quad t_w = 0.5 \text{ in}$$

$$\frac{D}{t_w} = 108.0$$

Another handling requirement is that the spacing of transverse stiffeners, d_o , must satisfy the following:

$$d_o \leq D \cdot \left[\frac{260}{\left(\frac{D}{t_w}\right)} \right]^2$$

$$D \cdot \left[\frac{260}{\left(\frac{D}{t_w}\right)} \right]^2 = 313.0 \text{ in}$$

Use $d_o = 80.0 \cdot \text{in}$ OK

This handling requirement for transverse stiffeners need only be enforced in regions where transverse stiffeners are no longer required for shear and where the web slenderness ratio exceeds 150. Therefore, this requirement must typically be applied only in the central regions of the spans of relatively deep girders, where the shear is low.

The nominal shear resistance of interior web panels of noncompact sections which are considered stiffened, as per S6.10.7.1, is as follows:

$$\text{Check if } f_u \leq 0.75 \cdot \phi_f \cdot F_y$$

The term, f_u , is the flexural stress in the compression or tension flange due to the factored loading, whichever flange has the maximum ratio of f_u to F_r in the panel under consideration.

$$f_u = 48.84 \cdot \text{ksi} \quad (\text{see Table 3-12})$$

$$0.75 \cdot \phi_f \cdot F_y = 37.5 \text{ ksi}$$

$$\text{Therefore, } f_u \geq 0.75 \cdot \phi_f \cdot F_y$$

$$V_n = R \cdot V_p \cdot \left[C + \frac{0.87 \cdot (1 - C)}{\sqrt{1 + \left(\frac{d_o}{D}\right)^2}} \right] \geq C \cdot V_p$$

$$k = 5 + \frac{5}{\left(\frac{d_o}{D}\right)^2} \quad k = 7.3$$

S6.10.7.3.2

S6.10.7.3.3b

S6.10.7.3.3a

$$\frac{D}{t_w} = 108.0$$

$$1.10 \cdot \sqrt{\frac{E \cdot k}{F_{yw}}} = 71.5$$

$$1.38 \cdot \sqrt{\frac{E \cdot k}{F_{yw}}} = 89.7$$

Therefore, $\frac{D}{t_w} \geq 1.38 \cdot \sqrt{\frac{E \cdot k}{F_{yw}}}$

$$C = \frac{1.52}{\left(\frac{D}{t_w}\right)^2} \cdot \left(\frac{E \cdot k}{F_{yw}}\right)$$

$$C = 0.550$$

The reduction factor applied to the factored shear, R, is computed as follows:

$$R = \left[0.6 + 0.4 \cdot \left(\frac{F_r - f_u}{F_r - 0.75 \phi_f \cdot F_y} \right) \right]$$

$$R = 0.637$$

$$V_p = 0.58 \cdot F_{yw} \cdot D \cdot t_w$$

$$V_p = 783.0 \text{ K}$$

$$R \cdot V_p \cdot \left[C + \frac{0.87 \cdot (1 - C)}{\sqrt{1 + \left(\frac{d_o}{D}\right)^2}} \right] = 383.7 \text{ K}$$

$$C \cdot V_p = 430.7 \text{ K}$$

$$V_n = \max \left[R \cdot V_p \cdot \left[C + \frac{0.87 \cdot (1 - C)}{\sqrt{1 + \left(\frac{d_o}{D}\right)^2}} \right], C \cdot V_p \right]$$

$$V_n = 430.7 \text{ K}$$

S6.10.7.3.3a

S6.10.7.3.3b

S6.10.7.3.3a&c

The factored shear resistance, V_r , is computed as follows:

$$\phi_v = 1.00$$

$$V_r = \phi_v \cdot V_n$$

$$V_r = 430.7 \text{ K}$$

As previously computed, for this design example:

$$\sum \eta_i \cdot \gamma_i \cdot V_i = 423.5 \cdot \text{K}$$

$$V_r = 430.7 \text{ K} \quad \text{OK}$$

Therefore, the girder design section at the pier satisfies the shear resistance requirements for the web.

Design Step 3.12 - Design Transverse Intermediate Stiffeners - Negative Moment Region

The girder in this design example has transverse intermediate stiffeners. Transverse intermediate stiffeners are used to increase the shear resistance of the girder. The shear resistance computations shown in the previous design step were based on a stiffener spacing of 80 inches.

In this design example, it is assumed that the transverse intermediate stiffeners consist of plates welded to one side of the web. The required interface between the transverse intermediate stiffeners and the top and bottom flanges is described in *S6.10.8.1.1*.

The transverse intermediate stiffener configuration is assumed to be as presented in the following figure.

S6.10.7.1

S6.5.4.2

S6.10.8.1

S6.10.8.1.1

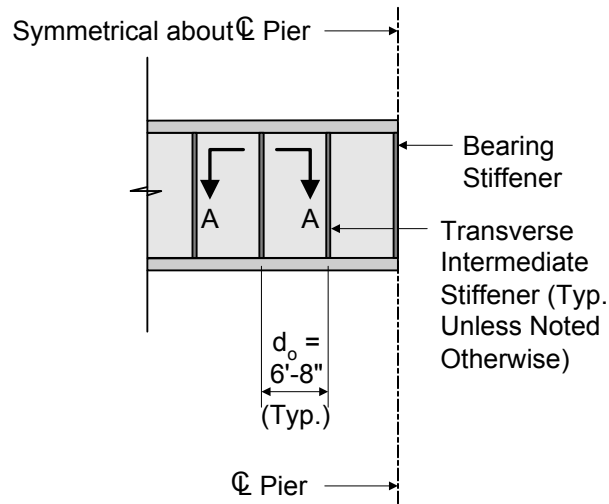

Partial Girder Elevation at Pier

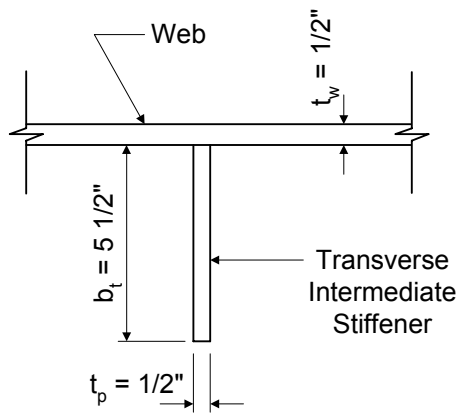

Section A-A

Figure 3-14 Transverse Intermediate Stiffener

The first specification check is for the projecting width of the transverse intermediate stiffener. The width, b_t , of each projecting stiffener element must satisfy the following:

$$b_t \geq 2.0 + \frac{d}{30.0} \quad \text{and} \quad 16.0 \cdot t_p \geq b_t \geq 0.25b_f$$

$$b_t = 5.5 \text{ in}$$

$$d = 59.25 \text{ in}$$

$$t_p = 0.50 \text{ in}$$

$$b_f = 14.0 \text{ in}$$

$$b_t = 5.5 \text{ in} \quad 2.0 + \frac{d}{30.0} = 3.98 \text{ in}$$

$$\text{Therefore,} \quad b_t \geq 2.0 + \frac{d}{30.0} \quad \text{OK}$$

$$16.0 \cdot t_p = 8.0 \text{ in}$$

$$0.25 \cdot b_f = 3.5 \text{ in}$$

$$\text{Therefore,} \quad 16.0 \cdot t_p \geq b_t \geq 0.25 \cdot b_f \quad \text{OK}$$

The second specification check is for the moment of inertia of the transverse intermediate stiffener. This requirement is intended to ensure sufficient rigidity. The moment of inertia of any transverse stiffener must satisfy the following:

$$I_t \geq d_o \cdot t_w^3 \cdot J$$

$$d_o = 80.0 \text{ in} \quad t_w = 0.50 \text{ in} \quad D = 54.0 \text{ in}$$

$$J = 2.5 \cdot \left(\frac{D}{d_o} \right)^2 - 2.0 \geq 0.5$$

$$2.5 \cdot \left(\frac{D}{d_o} \right)^2 - 2.0 = -0.9$$

$$\text{Therefore,} \quad J = 0.5$$

$$\text{Therefore,} \quad d_o \cdot t_w^3 \cdot J = 5.0 \text{ in}^4$$

$$I_t = \frac{t_p \cdot b_t^3}{3} \quad I_t = 27.7 \text{ in}^4$$

$$\text{Therefore,} \quad I_t \geq d_o \cdot t_w^3 \cdot J \quad \text{OK}$$

S6.10.8.1.2

S6.10.8.1.3

The third specification check is for the area of the transverse intermediate stiffener. This requirement is intended to ensure sufficient area to resist the vertical component of the tension field. The area of any transverse stiffener must satisfy the following:

S6.10.8.1.4

$$A_s \geq \left[0.15 \cdot B \cdot \frac{D}{t_w} \cdot (1 - C) \cdot \left(\frac{V_u}{V_r} \right) - 18 \right] \cdot \frac{F_{yw}}{F_{cr}} \cdot t_w^2$$

$$B = 2.4 \quad \text{for single plate stiffeners}$$

$$D = 54.0 \text{ in}$$

$$t_w = 0.50 \text{ in}$$

$$C = 0.550$$

$$V_u = 423.5 \cdot K$$

$$V_r = 430.7 K$$

$$F_{yw} = 50.0 \text{ ksi}$$

$$E = 29000 \text{ ksi}$$

$$b_t = 5.5 \text{ in}$$

$$t_p = 0.5 \text{ in}$$

$$F_{cr} = \frac{0.311 \cdot E}{\left(\frac{b_t}{t_p} \right)^2} \leq F_{ys}$$

$$\frac{0.311 \cdot E}{\left(\frac{b_t}{t_p} \right)^2} = 74.5 \text{ ksi} \quad F_{ys} = 50.0 \cdot \text{ksi}$$

$$\text{Therefore, } F_{cr} = 50.0 \cdot \text{ksi}$$

$$\left[0.15 \cdot B \cdot \frac{D}{t_w} \cdot (1 - C) \cdot \left(\frac{V_u}{V_r} \right) - 18 \right] \cdot \frac{F_{yw}}{F_{cr}} \cdot t_w^2 = -0.2 \text{ in}^2$$

Therefore, the specification check for area is automatically satisfied.

Therefore, the transverse intermediate stiffeners as shown in Figure 3-13 satisfy all of the required specification checks.

Design Step 3.14 - Design for Flexure - Fatigue and Fracture Limit State - Negative Moment Region

For this design example, the nominal fatigue resistance computations were presented previously for the girder section at the location of maximum positive moment. Detail categories are explained and illustrated in *S*Table 6.6.1.2.3-1 and *S*Figure 6.6.1.2.3-1.

S6.6.1

In addition to the nominal fatigue resistance computations, fatigue requirements for webs must also be checked. These checks are required to control out-of-plane flexing of the web due to flexure or shear under repeated live loading.

S6.10.6

S6.10.6.1

For this check, the live load flexural stress and shear stress resulting from the fatigue load must be taken as twice that calculated using the fatigue load combination in Table 3-1.

S6.10.6.2

As previously explained, for this design example, the concrete slab is assumed to be fully effective for both positive and negative flexure for fatigue limit states. This is permissible because the provisions of S6.10.3.7 were satisfied in Design Step 2.

S6.6.1.2.1

For flexure, the fatigue requirement for the web is as follows:

S6.10.6.3

$$\text{If } \frac{D}{t_w} \leq 0.95 \cdot \sqrt{\frac{k \cdot E}{F_{yw}}} \quad \text{then } F_{cf} \leq F_{yw}$$

$$\text{Otherwise } f_{cf} \leq 0.9 \cdot k \cdot E \cdot \left(\frac{t_w}{D}\right)^2$$

$$D = 54.0 \text{ in}$$

$$D_c = 29.92 \text{ in}$$

For the fatigue limit state at the pier (the location of maximum negative moment):

S6.10.3.1.4a

$$f_{\text{botgdr}} = (-16.84 \cdot \text{ksi}) + (-2.02 \cdot \text{ksi}) + (-2.44 \text{ ksi}) \dots \\ + (2 \cdot 0.75 \cdot -1.75 \cdot \text{ksi})$$

$$f_{\text{botgdr}} = -23.93 \text{ ksi}$$

$$f_{\text{topgdr}} = (17.90 \cdot \text{ksi}) + (1.15 \cdot \text{ksi}) + (1.39 \text{ ksi}) \dots \\ + (2 \cdot 0.75 \cdot 0.47 \cdot \text{ksi})$$

$$f_{\text{topgdr}} = 21.14 \text{ ksi}$$

$$t_{\text{topfl}} = 2.50\text{in} \quad (\text{see Figure 3-4})$$

$$D_{\text{web}} = 54\text{in} \quad (\text{see Figure 3-4})$$

$$t_{\text{botfl}} = 2.75\text{in} \quad (\text{see Figure 3-4})$$

$$\text{Depth}_{\text{gdr}} = t_{\text{topfl}} + D_{\text{web}} + t_{\text{botfl}}$$

$$\text{Depth}_{\text{gdr}} = 59.25\text{in}$$

$$\text{Depth}_{\text{comp}} = \frac{-f_{\text{botgdr}}}{f_{\text{topgdr}} - f_{\text{botgdr}}} \cdot \text{Depth}_{\text{gdr}}$$

$$\text{Depth}_{\text{comp}} = 31.45\text{in}$$

$$D_{\text{c}} = \text{Depth}_{\text{comp}} - t_{\text{botfl}}$$

$$D_{\text{c}} = 28.70\text{in}$$

$$k = 9.0 \cdot \left(\frac{D}{D_{\text{c}}}\right)^2 \geq 7.2 \quad 9.0 \cdot \left(\frac{D}{D_{\text{c}}}\right)^2 = 31.9$$

$$k = \max\left[9.0 \cdot \left(\frac{D}{D_{\text{c}}}\right)^2, 7.2\right] \quad k = 31.9$$

$$\frac{D}{t_{\text{w}}} = 108.0 \quad 0.95 \cdot \sqrt{\frac{k \cdot E}{F_{\text{yw}}}} = 129.1$$

Therefore,
$$\frac{D}{t_{\text{w}}} \leq 0.95 \cdot \sqrt{\frac{k \cdot E}{F_{\text{yw}}}}$$

Based on the unfactored stress values in Table 3-12:

$$f_{\text{cf}} = (-16.84 \cdot \text{ksi}) + (-2.02 \cdot \text{ksi}) + (-2.44 \text{ksi}) \dots \\ + (2 \cdot 0.75 \cdot -1.75 \cdot \text{ksi})$$

$$f_{\text{cf}} = -23.93 \text{ksi} \quad F_{\text{yw}} = 50.0 \text{ksi}$$

Therefore, $f_{\text{cf}} \leq F_{\text{yw}}$ OK

C6.10.3.1.4a

For shear, the fatigue requirement for the web is as follows:

$$v_{cf} \leq 0.58 \cdot C \cdot F_{yw}$$

Based on the unfactored shear values in Table 3-13:

$$V_{cf} = 114.7 \cdot K + 16.4 \cdot K + 19.8 \cdot K + (2 \cdot 0.75 \cdot 46.5 \cdot K)$$

$$V_{cf} = 220.7 K$$

$$D = 54.0 \text{ in}$$

$$t_w = 0.50 \text{ in}$$

$$v_{cf} = \frac{V_{cf}}{D \cdot t_w}$$

$$v_{cf} = 8.17 \text{ ksi}$$

$$C = 0.550$$

$$F_{yw} = 50.0 \text{ ksi}$$

$$0.58 \cdot C \cdot F_{yw} = 15.95 \text{ ksi}$$

Therefore, $v_{cf} \leq 0.58 \cdot C \cdot F_{yw}$ OK

Therefore, the fatigue requirements for webs for both flexure and shear are satisfied.

Design Step 3.15 - Design for Flexure - Service Limit State - Negative Moment Region

The girder must be checked for service limit state control of permanent deflection. This check is intended to prevent objectionable permanent deflections due to expected severe traffic loadings that would impair rideability. Service II Limit State is used for this check.

This check will not control for composite noncompact sections under the load combinations given in *S*Table 3.4.1-1. Although a web bend buckling check is also required in regions of positive flexure at the service limit state according to the current specification language, it is unlikely that such a check would control in these regions for composite girders without longitudinal stiffeners since D_c is relatively small for such girders in these regions.

The web must satisfy *S*Equation 6.10.3.2.2-1, using the appropriate value of the depth of the web in compression in the elastic range, D_c .

S6.10.6.4

S6.10.5

C6.10.5.1

S6.10.5.1

$$f_{cw} \leq \frac{0.9 \cdot E \cdot \alpha \cdot k}{\left(\frac{D}{t_w}\right)^2} \leq F_{yw}$$

for which:

$$E = 29000 \text{ ksi}$$

$$\alpha = 1.25 \quad \text{for webs without longitudinal stiffeners}$$

$$D = 54.0 \text{ in}$$

The factored Service II flexural stress was previously computed in Table 3-12 as follows:

$$f_{\text{botgdr}} = -35.01 \cdot \text{ksi}$$

$$f_{\text{topgdr}} = 24.12 \cdot \text{ksi}$$

$$\text{Depth}_{\text{gdr}} = 59.25 \text{ in} \quad (\text{see Figure 3-4})$$

$$\text{Depth}_{\text{comp}} = \frac{-f_{\text{botgdr}}}{f_{\text{topgdr}} - f_{\text{botgdr}}} \cdot \text{Depth}_{\text{gdr}}$$

$$\text{Depth}_{\text{comp}} = 35.08 \text{ in}$$

$$D_c = \text{Depth}_{\text{comp}} - t_{\text{botfl}}$$

$$D_c = 32.33 \text{ in}$$

$$k = 9.0 \cdot \left(\frac{D}{D_c}\right)^2 \geq 7.2 \quad \text{for webs without longitudinal stiffeners}$$

$$9.0 \cdot \left(\frac{D}{D_c}\right)^2 = 25.1$$

$$k = \max \left[9.0 \cdot \left(\frac{D}{D_c}\right)^2, 7.2 \right] \quad k = 25.1$$

$$t_w = 0.5 \text{ in} \quad (\text{see Figure 3-4})$$

$$\frac{0.9 \cdot E \cdot \alpha \cdot k}{\left(\frac{D}{t_w}\right)^2} = 70.23 \text{ ksi}$$

$$F_{yw} = 50.0 \text{ ksi}$$

$$\min \left[\frac{0.9 \cdot E \cdot \alpha \cdot k}{\left(\frac{D}{t_w}\right)^2}, F_{yw} \right] = 50.0 \text{ ksi}$$

$$f_{cw} = f_{botgdr} \cdot \left(\frac{D_c}{D_c + t_f} \right)$$

$$f_{cw} = -32.27 \text{ ksi} \quad \text{OK}$$

In addition, the flange stresses for both steel flanges of composite sections must satisfy the following requirement:

$$f_f \leq 0.95F_{yf}$$

As previously explained, for this design example, the concrete slab is assumed to be fully effective for both positive and negative flexure for service limit states.

The factored Service II flexural stress was previously computed in Table 3-12 as follows:

$$f_{botgdr} = -35.01 \cdot \text{ksi}$$

$$f_{topgdr} = 24.12 \cdot \text{ksi}$$

$$F_{yf} = 50.0 \text{ ksi}$$

$$0.95 \cdot F_{yf} = 47.50 \text{ ksi} \quad \text{OK}$$

In addition to the check for service limit state control of permanent deflection, the girder can also be checked for live load deflection. Although this check is optional for a concrete deck on steel girders, it is included in this design example at the location of maximum positive moment.

S6.10.5.1

S2.5.2.6.2

Design Step 3.16 - Design for Flexure - Constructibility Check - Negative Moment Region

The girder must also be checked for flexure during construction. The girder has already been checked in its final condition when it behaves as a composite section. The constructibility must also be checked for the girder prior to the hardening of the concrete deck when the girder behaves as a noncomposite section.

S6.10.3.2.2

The investigation of the constructibility of the girder begins with the the noncompact section compression-flange slenderness check, as follows:

S6.10.4.1.4

$$\frac{b_f}{2 \cdot t_f} \leq 12.0$$

$$b_f = 14 \text{ in} \quad (\text{see Figure 3-4})$$

$$t_f = 2.75 \text{ in} \quad (\text{see Figure 3-4})$$

$$\frac{b_f}{2 \cdot t_f} = 2.5$$

In addition, composite girders, when they are not yet composite, must satisfy the following requirement during construction:

S6.10.3.2.2

$$f_{cw} \leq \frac{0.9 \cdot E \cdot \alpha \cdot k}{\left(\frac{D}{t_w}\right)^2} \leq F_{yw}$$

for which:

$$E = 29000 \text{ ksi}$$

$$\alpha = 1.25 \quad \text{for webs without longitudinal stiffeners}$$

$$D = 54.0 \text{ in}$$

For the noncomposite loads during construction:

$$f_{\text{botgdr}} = 1.25 \cdot (-16.84 \cdot \text{ksi})$$

$$f_{\text{botgdr}} = -21.05 \text{ ksi}$$

$$f_{\text{topgdr}} = 1.25 \cdot (17.90 \cdot \text{ksi})$$

$$f_{\text{topgdr}} = 22.37 \text{ ksi}$$

$$\text{Depth}_{\text{gdr}} = 59.25 \text{ in} \quad (\text{see Figure 3-4})$$

$$\text{Depth}_{\text{comp}} = \frac{-f_{\text{botgdr}}}{f_{\text{topgdr}} - f_{\text{botgdr}}} \cdot \text{Depth}_{\text{gdr}}$$

$$\text{Depth}_{\text{comp}} = 28.72 \text{ in}$$

$$D_c = \text{Depth}_{\text{comp}} - t_{\text{botfl}}$$

$$D_c = 25.97 \text{ in}$$

$$k = 9.0 \cdot \left(\frac{D}{D_c} \right)^2 \geq 7.2 \quad \text{for webs without longitudinal stiffeners}$$

$$9.0 \cdot \left(\frac{D}{D_c} \right)^2 = 38.9$$

$$k = \max \left[9.0 \cdot \left(\frac{D}{D_c} \right)^2, 7.2 \right] \quad k = 38.9$$

$$t_w = 0.5 \text{ in} \quad (\text{see Figure 3-4})$$

$$\frac{0.9 \cdot E \cdot \alpha \cdot k}{\left(\frac{D}{t_w} \right)^2} = 108.83 \text{ ksi}$$

$$F_{yw} = 50.0 \text{ ksi}$$

$$\min \left[\frac{0.9 \cdot E \cdot \alpha \cdot k}{\left(\frac{D}{t_w} \right)^2}, F_{yw} \right] = 50.0 \text{ ksi}$$

$$f_{cw} = f_{\text{botgdr}} \cdot \left(\frac{D_c}{D_c + t_f} \right)$$

$$f_{cw} = -19.03 \text{ ksi} \quad \text{OK}$$

C6.10.3.1.4a

In addition to checking the nominal flexural resistance in the web during construction, the nominal shear resistance in the web must also be checked as follows:

$$V_n = C \cdot V_p$$

$$C = 0.550$$

$$V_p = 783.0 \text{ K}$$

$$V_n = 430.7 \text{ K}$$

$$\phi_v = 1.0$$

$$V_r = \phi_v \cdot V_n$$

$$V_r = 430.7 \text{ K}$$

$$V_u = (1.25 \cdot 114.7 \cdot \text{K}) + (1.25 \cdot 16.4 \cdot \text{K}) + (1.50 \cdot 19.8 \cdot \text{K})$$

$$V_u = 193.6 \text{ K} \quad \text{OK}$$

Therefore, the design section at the pier satisfies the constructibility specification checks.

Design Step 3.17 - Check Wind Effects on Girder Flanges - Negative Moment Region

As stated in Design Step 3.3, for this design example, the interior girder controls and is being designed.

Wind effects generally do not control a steel girder design, and they are generally considered for the exterior girders only. However, for illustrative purposes, wind effects are presented below for the girder design section at the pier. A bridge height of greater than 30 feet is used in this design step to illustrate the required computations.

For noncompact sections, the stresses in the bottom flange are combined as follows:

$$(F_u + F_w) \leq F_r$$

$$F_w = \frac{6 \cdot M_w}{t_{fb} \cdot b_{fb}^2}$$

S6.10.3.2.3

S6.5.4.2

S6.10.3.5

C6.10.3.5.2 &
C4.6.2.7.1

S3.8.1.1

S6.10.3.5.2

Since the deck provides horizontal diaphragm action and since there is wind bracing in the superstructure, the maximum wind moment on the loaded flange is determined as follows:

$$M_w = \frac{W \cdot L_b^2}{10}$$

$$L_b = 20.0 \text{ ft}$$

$$W = \frac{\eta \cdot \gamma \cdot P_D \cdot d}{2}$$

$$\eta = 1.0$$

C4.6.2.7.1

S1.3



Strength Limit States for Wind on Structure

For the strength limit state, wind on the structure is considered for the Strength III and Strength V Limit States. For Strength III, the load factor for wind on structure is 1.40 but live load is not considered. Due to the magnitude of the live load stresses, Strength III will clearly not control for this design example (and for most designs). Therefore, for this design example, the Strength V Limit State will be investigated.

$$\gamma = 0.40 \quad \text{for Strength V Limit State}$$

STable 3.4.1-1

Assume that the bridge is to be constructed in Pittsburgh, Pennsylvania. The design horizontal wind pressure is computed as follows:

$$P_D = P_B \cdot \left(\frac{V_{DZ}}{V_B} \right)^2$$

$$P_B = 0.050 \cdot \text{ksf}$$

$$V_B = 100 \text{ MPH}$$

S3.8.1.2

STable
3.8.1.2.1-1

$$V_{DZ} = 2.5 \cdot V_o \cdot \left(\frac{V_{30}}{V_B} \right) \cdot \ln \left(\frac{Z}{Z_o} \right)$$

S3.8.1.1

$V_o = 12.0$ MPH for a bridge located in a city

STable
3.8.1.1-1

$V_{30} = 60$ MPH assumed wind velocity at 30 feet above low ground or above design water level at bridge site

$V_B = 100$ MPH

S3.8.1.1

$Z = 35$ -ft assumed height of structure at which wind loads are being calculated as measured from low ground or from water level

$Z_o = 8.20$ -ft for a bridge located in a city

STable
3.8.1.1-1

$$V_{DZ} = 2.5 \cdot V_o \cdot \left(\frac{V_{30}}{V_B} \right) \cdot \ln \left(\frac{Z}{Z_o} \right)$$

S3.8.1.1

$V_{DZ} = 26.1$ MPH

$$P_D = P_B \cdot \left(\frac{V_{DZ}}{V_B} \right)^2$$

S3.8.1.2.1

$P_D = 0.00341$ ksf

After the design horizontal wind pressure has been computed, the factored wind force per unit length applied to the flange is computed as follows:

C4.6.2.7.1

$$W = \frac{\eta \cdot \gamma \cdot P_D \cdot d}{2}$$

$\eta = 1.0$

S1.3

$\gamma = 0.40$

for Strength V Limit State

STable 3.4.1-1

$P_D = 0.00341$ ksf

$d = 9.23$ -ft from bottom of girder to top of parapet

$$W = \frac{\eta \cdot \gamma \cdot P_D \cdot d}{2}$$

$$W = 0.00630 \frac{\text{K}}{\text{ft}}$$

Next, the maximum lateral moment in the flange due to the factored wind loading is computed as follows:

$$M_w = \frac{W \cdot L_b^2}{10}$$

$$W = 0.00630 \frac{\text{K}}{\text{ft}}$$

$$L_b = 20.0 \text{ ft}$$

$$M_w = 0.252 \text{ K} \cdot \text{ft}$$

Finally, the flexural stress at the edges of the bottom flange due to factored wind loading is computed as follows:

$$F_w = \frac{6 \cdot M_w}{t_{fb} \cdot b_{fb}^2}$$

$$M_w = 0.252 \text{ K} \cdot \text{ft}$$

$$t_{fb} = 2.75 \cdot \text{in}$$

$$b_{fb} = 14.0 \cdot \text{in}$$

$$F_w = \frac{6 \cdot M_w}{t_{fb} \cdot b_{fb}^2}$$

$$F_w = 0.034 \text{ ksi}$$

The load factor for live load is 1.35 for the Strength V Limit State. However, it is 1.75 for the Strength I Limit State, which we have already investigated. Therefore, it is clear that wind effects will not control the design of this steel girder. Nevertheless, the following computations are presented simply to demonstrate that wind effects do not control this design:

C4.6.2.7.1

S6.10.3.5.2

$$F_U = (1.25 \cdot -16.84 \text{ksi}) + (1.25 \cdot -2.15 \text{ksi}) \dots + (1.50 \cdot -2.61 \cdot \text{ksi}) + (1.35 \cdot -12.11 \cdot \text{ksi})$$

$$F_U = -44.00 \text{ksi}$$

$$F_W = -0.028 \cdot \text{ksi}$$

$$F_U + F_W = -44.03 \text{ksi}$$

$$F_r = 50.0 \text{ksi}$$

Therefore: $(F_U + F_W) \leq F_r$ OK

Therefore, wind effects do not control the design of this steel girder.

Design Step 3.18 - Draw Schematic of Final Steel Girder Design

Since all of the specification checks were satisfied, the trial girder section presented in Design Step 3.2 is acceptable. If any of the specification checks were not satisfied or if the design were found to be overly conservative, then the trial girder section would need to be revised appropriately, and the specification checks would need to be repeated for the new trial girder section.

The following is a schematic of the final steel girder configuration:

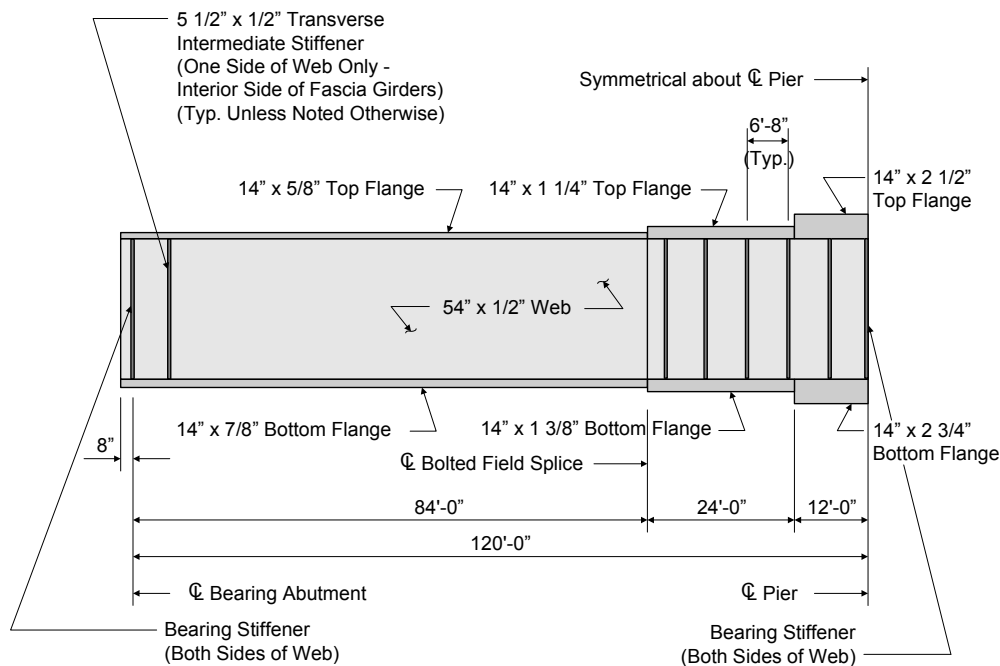

Figure 3-15 Final Plate Girder Elevation

For this design example, only the location of maximum positive moment, the location of maximum negative moment, and the location of maximum shear were investigated. However, the above schematic shows the plate sizes and stiffener spacing throughout the entire length of the girder. Some of the design principles for this design example are presented in "tip boxes."

Design computations for a bolted field splice are presented in Design Step 4. Design computations and principles for shear connectors, bearing stiffeners, welded connections, and cross-frames are presented in Design Step 5. Design computations for an elastomeric bearing pad are presented in Design Step 6.

Bolted Field Splice Design Example Design Step 4

Table of Contents

	<u>Page</u>
Design Step 4.1 - Obtain Design Criteria	1
Design Step 4.2 - Select Girder Section as Basis for Field Splice Design	6
Design Step 4.3 - Compute Flange Splice Design Loads	6
Design Step 4.4 - Design Bottom Flange Splice	31
Design Step 4.5 - Design Top Flange Splice	60
Design Step 4.6 - Compute Web Splice Design Loads	61
Design Step 4.7 - Design Web Splice	77
Design Step 4.8 - Draw Schematic of Final Bolted Field Splice Design	103

Design Step 4.1 - Obtain Design Criteria

This splice design example is based on *AASHTO LRFD Bridge Design Specifications* (through 2002 interims). The design methods presented throughout the example are meant to be the most widely used in general bridge engineering practice.

The first design step is to identify the appropriate design criteria. This includes, but is not limited to, defining material properties, identifying relevant superstructure information, and determining the splice location.

Refer to Design Step 1 for introductory information about this design example. Additional information is presented about the design assumptions, methodology, and criteria for the entire bridge, including the splice.

Presented in Figure 4-1 is the final steel girder configuration as designed in Design Step 3. Included in Figure 4-1 is the bolted field splice location. This location was determined using the criteria presented in the narrative below.

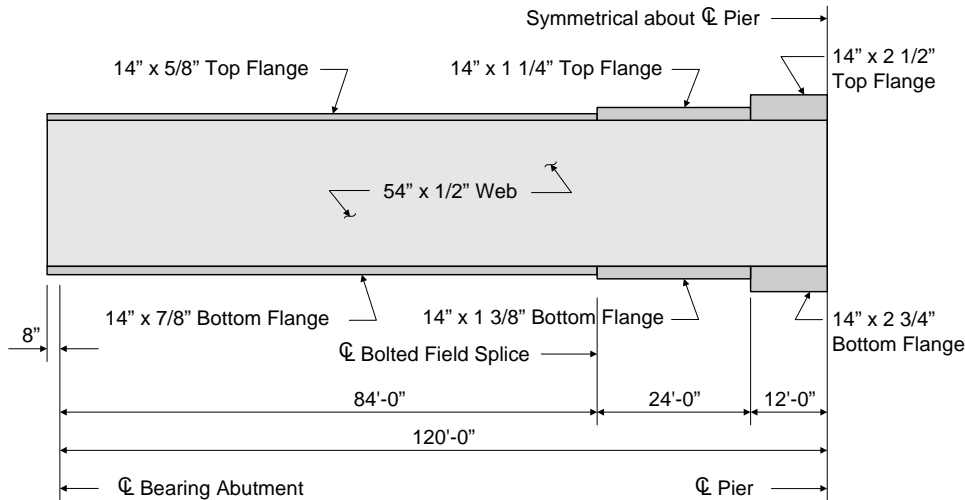

Figure 4-1 Plate Girder Elevation

The following units are defined for use in this design example:

$$K = 1000\text{lb} \quad kcf = \frac{K}{\text{ft}^3} \quad \text{ksi} = \frac{K}{\text{in}^2}$$

For relatively long girders, field splices are generally required to reduce the girder shipping length. The location of the field splice is generally based on economy and includes the following considerations:

1. Field splices are generally located to provide girder segment lengths that do not exceed the allowable girder shipping length. The allowable girder shipping length is often a function of the shipping route from the fabrication site to the construction site.
2. The Specifications recommends locating splices near points of dead load contraflexure.
3. Field splices are generally located where total moment in the girder is relatively small. This minimizes the required splice plate thicknesses and the required number of bolts.

S6.13.6.1.4a

In Design Step 1.1, the steel properties of the girder were defined. These properties will be used for the splice plates as well.

Yield Strength: $F_y = 50 \cdot \text{ksi}$

Tensile Strength: $F_u = 65 \cdot \text{ksi}$

For Specifications equations requiring the flange yield strength:

Flange Yield Strength: $F_{yf} = 50 \cdot \text{ksi}$

STable 6.4.1-1

Plate Dimensions of the Left Girder (reference Design Step 3.18):

Web Thickness: $t_w = 0.50 \cdot \text{in}$

Web Depth: $D = 54 \cdot \text{in}$

Top Flange Width: $b_{ftL} = 14 \cdot \text{in}$

Top Flange Thickness: $t_{ftL} = 0.625 \cdot \text{in}$

Bottom Flange Width: $b_{fbL} = 14 \cdot \text{in}$

Bottom Flange Thickness: $t_{fbL} = 0.875 \cdot \text{in}$

Plate Dimensions of the Right Girder (reference Design Step 3.18):

Web Thickness: $t_w = 0.50 \cdot \text{in}$

Web Depth: $D = 54 \cdot \text{in}$

Top Flange Width: $b_{ftR} = 14 \cdot \text{in}$

Top Flange Thickness: $t_{ftR} = 1.125 \cdot \text{in}$

Bottom Flange Width: $b_{fbR} = 14 \cdot \text{in}$

Bottom Flange Thickness: $t_{fbR} = 1.375 \cdot \text{in}$

Splice Bolt Properties:

Bolt Diameter:	$d_{\text{bolt}} = 0.875 \cdot \text{in}$	S6.13.2.5
Bolt Hole Diameter: (for design purposes)	$d_{\text{hole}} = 1.0 \cdot \text{in}$	S6.8.3
Bolt Tensile Strength:	$F_{\text{ubolt}} = 120 \cdot \text{ksi}$	S6.4.3.1

Concrete Deck Properties (reference Design Step 3.3):

Effective Slab Thickness:	$t_{\text{seff}} = 8 \cdot \text{in}$
Modular Ratio:	$n = 8$
Haunch Depth (measured from top of web):	$d_{\text{haunch}} = 3.5 \cdot \text{in}$
Effective Flange Width:	$W_{\text{eff}} = 103 \cdot \text{in}$

Based on the concrete deck design example and as illustrated in Figure 2-18, the area of longitudinal deck reinforcing steel in the negative moment region is computed as follows:

For the top steel:

$$A_{\text{deckreinftop}} = (0.31 \cdot \text{in}^2) \cdot \frac{W_{\text{eff}}}{5 \cdot \text{in}}$$

$$A_{\text{deckreinftop}} = 6.386 \text{in}^2$$

For the bottom steel:

$$A_{\text{deckreinfbot}} = (0.31 \cdot \text{in}^2) \cdot \frac{W_{\text{eff}}}{5 \cdot \text{in}}$$

$$A_{\text{deckreinfbot}} = 6.386 \text{in}^2$$

Resistance Factors:

Flexure:	$\phi_f = 1.0$
Shear:	$\phi_v = 1.0$
Axial Compression:	$\phi_c = 0.90$
Tension, fracture in net section:	$\phi_u = 0.80$
Tension, yielding in gross section:	$\phi_y = 0.95$
Bolts bearing on material:	$\phi_{bb} = 0.80$
A325 and A490 bolts in shear:	$\phi_s = 0.80$
Block shear:	$\phi_{bs} = 0.80$

S6.5.4.2

Design Step 4.2 - Select Girder Section as Basis for Field Splice Design

S6.13.6.1.1

Where a section changes at a splice, the smaller of the two connected sections shall be used in the design. Therefore, the bolted field splice will be designed based on the left adjacent girder section properties. This will be referred to as the Left Girder throughout the calculations. The girder located to the right of the bolted field splice will be designated the Right Girder.

Design Step 4.3 - Compute Flange Splice Design Loads

Girder Moments at the Splice Location:

Based on the properties defined in Design Step 3 (Steel Girder Design), any number of commercially available software programs can be used to obtain the design dead and live loads at the splice. For this design example, the AASHTO Opis software was used. A summary of the unfactored moments at the splice from the initial trial of the girder design are listed below. The live loads include impact and distribution factors.

Loads

Moments

Dead Loads:

Noncomposite: $M_{NDL} = -51.8 \cdot K \cdot ft$

Composite: $M_{CDL} = 15.5 \cdot K \cdot ft$

Future Wearing Surface: $M_{FWS} = 18.8 \cdot K \cdot ft$

Live Loads:

HL-93 Positive: $M_{PLL} = 1307.8 \cdot K \cdot ft$

HL-93 Negative: $M_{NLL} = -953.3 \cdot K \cdot ft$

Fatigue Positive: $M_{PFLL} = 394.3 \cdot K \cdot ft$

Fatigue Negative: $M_{NFLL} = -284.0 \cdot K \cdot ft$

Typically, splices are designed for the Strength I, Service II, and Fatigue Limit States. The load factors for these limit states are shown in Table 4-1:

Load	Load Factors					
	Strength I		Service II		Fatigue	
	γ_{max}	γ_{min}	γ_{max}	γ_{min}	γ_{max}	γ_{min}
DC	1.25	0.90	1.00	1.00	-	-
DW	1.50	0.65	1.00	1.00	-	-
LL	1.75	1.75	1.30	1.30	0.75	0.75

Table 4-1 Load Factors

Flange Stress Computation Procedure:

As previously mentioned, the applicable limit states for the splice design are Strength I, Service II, and Fatigue. The stresses corresponding to these limit states will be computed at the midthickness of the top and bottom flanges. The appropriate section properties and load factors for use in computing stresses are described below. Where necessary, refer to the signs of the previously documented design moments.

Strength I Limit State:

At the strength limit state, the section properties for flexural members with holes in the tension flange shall be computed using an effective flange area.

Case 1: Dead Load + Positive Live Load

For this case, stresses will be computed using the effective top flange area for the noncomposite dead load, and the effective bottom flange area for the composite dead load, future wearing surface, and live load. The minimum load factor is used for the DC dead loads (noncomposite and composite) and the maximum load factor is used for the future wearing surface. The composite dead load and future wearing surface act on the 3n- or the n-composite slab section, whichever gives the higher stresses, and the live load acts on the n-composite slab section.

S6.13.6

STable 3.4.1-1

STable 3.4.1-2

S6.13.6

S6.10.3.6

STable 3.4.1-2

S6.10.3.1.1b

Case 2: Dead Load + Negative Live Load

For this case, stresses will be computed using the effective top flange area for all loads. The future wearing surface is excluded and the maximum load factor is used for the DC dead loads. The live load acts on the composite steel girder plus longitudinal reinforcement section. The composite dead load is applied to this section as well, as a conservative assumption for simplicity and convenience, since the net effect of the live load is to induce tension in the slab. The reinforcing steel in the deck that is used corresponds to the negative moment deck reinforcement shown in Figure 2-18.

Service II Limit State:

S6.13.6.1.4a

Case 1: Dead Load + Positive Live Load

For this case, stresses will be computed using the gross steel section. The future wearing surface is included and acts, along with the composite dead load, on the 3n- or n-composite slab section, whichever gives the higher stresses. The live load acts on the n-composite slab section.

Case 2: Dead Load + Negative Live Load

S6.10.3.1.1c

For this case, stresses will be computed using the gross steel section. The future wearing surface is excluded. The composite dead load acts on the 3n- or n-composite slab section, whichever gives the larger stresses. The live load acts on the n-composite slab section.

Fatigue Limit State:

C6.13.6.1.4a

Case 1: Positive Live Load

For this case, stresses will be computed using the gross steel section. The live load acts on the n-composite slab section.

Case 2: Negative Live Load

S6.10.3.1.1c

For this case, stresses will be computed using the gross steel section. The live load acts on the n-composite slab section.

Section Properties:

Effective Flange Areas:

$$A_e = A_n + \beta \cdot A_g \leq A_g$$

For holes equal to or less than 1.25 inches in diameter:

$$\beta = \left(\frac{A_n}{A_g} \right) \cdot \left[\left(\frac{\phi_u \cdot F_u}{\phi_y \cdot F_{yf}} \right) - 1 \right] \geq 0.0$$

The effective area of the bottom flange of the steel girder is as follows:

$$A_g = t_{flb}L \cdot b_{flb}L \qquad A_g = 12.25 \text{ in}^2$$

The net area of the bottom flange of the steel girder is defined as the product of the thickness of the flange and the smallest net width. The net width is determined by subtracting from the width of the flange the sum of the widths of all holes in the assumed failure chain, and then adding the quantity $s^2/4g$ for each space between consecutive holes in the chain. Since the bolt holes in the flanges are lined up transverse to the loading direction, the governing failure chain is straight across the flange (i.e., $s^2/4g$ is equal to zero).

The net area of the bottom flange of the steel girder now follows:

$$A_n = (b_{flb}L - 4 \cdot d_{hole}) \cdot t_{flb}L \qquad A_n = 8.75 \text{ in}^2$$

$$\beta = \left(\frac{A_n}{A_g} \right) \cdot \left[\left(\frac{\phi_u \cdot F_u}{\phi_y \cdot F_{yf}} \right) - 1 \right] \qquad \beta = 0.07$$

S6.13.6.1.4c
S6.10.3.6SEquation
6.10.3.6-1

S6.8.3

With the gross and net areas identified, along with beta, the effective tension area of the bottom flange can now be computed as follows:

$$A_e = A_n + \beta \cdot A_g$$

$$A_e = 9.58 \text{ in}^2$$

Check:

$$A_e = 9.58 \text{ in}^2 < A_g = 12.25 \text{ in}^2 \quad \text{OK}$$

Effective bottom flange area: $A_{e\text{bot}} = 9.58 \cdot \text{in}^2$

Similar calculations determine the effective tension area for the top flange of the steel girder:

Effective top flange area: $A_{e\text{top}} = 6.84 \cdot \text{in}^2$

The transformed effective area of the concrete flange of the steel girder is now determined. This requires the modular ratio as follows:

$$A_c = \frac{\text{Effective Slab Width}}{\text{Modular Ratio}} \times t_{\text{seff}}$$

where:

$$\text{Effective Slab Width: } W_{\text{eff}} = 103 \text{ in}$$

$$\text{Modular Ratio: } n = 8$$

For the n-composite beam:

$$A_c = \frac{W_{\text{eff}}}{n} \cdot t_{\text{seff}} \quad A_c = 103.00 \text{ in}^2$$

For the 3n-composite beam:

$$A_{c3n} = \frac{W_{\text{eff}}}{3n} \cdot t_{\text{seff}} \quad A_{c3n} = 34.33 \text{ in}^2$$

The section properties for the Left Girder are calculated with the aid of Figure 4-2 shown below:

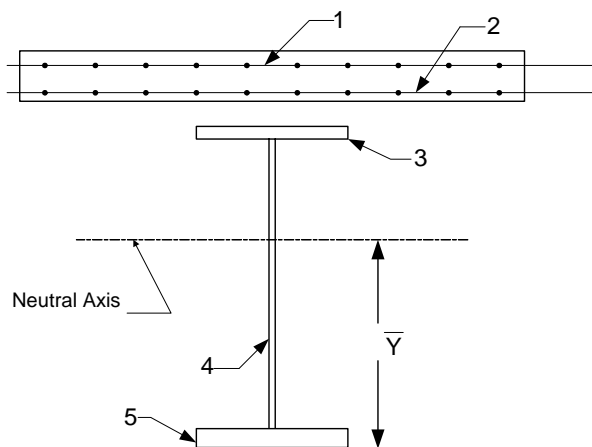

Figure 4-2 Girder, Slab and Longitudinal Reinforcement

The following tables contain the section properties for the left (i.e., smaller) girder section at the splice location. The properties in Table 4-2 are based on the gross area of the steel girder, and these properties are used for computation of stresses for the Service II and Fatigue Limit States. The properties in Tables 4-3 and 4-4 are based on the effective top flange and effective bottom flange of the steel girder, respectively, and these properties are used for computation of stresses for the Strength I Limit State.

Gross Section Properties						
Section	Area, A (Inches ²)	Centroid, d (Inches)	A*d (Inches ³)	I _o (Inches ⁴)	A*y ² (Inches ⁴)	I _{total} (Inches ⁴)
Girder only:						
Top flange	8.750	55.188	482.9	0.3	7530.2	7530.5
Web	27.000	27.875	752.6	6561.0	110.5	6671.5
Bottom flange	12.250	0.438	5.4	0.8	7912.0	7912.7
Total	48.000	25.852	1240.9	6562.1	15552.7	22114.8
Composite (3n):						
Girder	48.000	25.852	1240.9	22114.8	11134.4	33249.2
Slab	34.333	62.375	2141.5	183.1	15566.5	15749.6
Total	82.333	41.082	3382.4	22297.9	26700.8	48998.7
Composite (n):						
Girder	48.000	25.852	1240.9	22114.8	29792.4	51907.2
Slab	103.000	62.375	6424.6	549.3	13883.8	14433.2
Total	151.000	50.765	7665.5	22664.1	43676.2	66340.3
Section	Y _{botmid} (Inches)	Y _{topmid} (Inches)	S _{botweb} (Inches ³)	S _{botmid} (Inches ³)	S _{topmid} (Inches ³)	S _{topweb} (Inches ³)
Girder only	25.414	29.336	885.4	870.2	753.8	762.0
Composite (3n)	40.644	14.106	1218.7	1205.5	3473.7	3552.4
Composite (n)	50.327	4.423	1329.7	1318.2	15000.3	16140.8

Table 4-2 Section Properties Based on Gross Steel Section

Section Properties - Effective Top Flange Area						
Section	Area, A (Inches ²)	Centroid, d (Inches)	A*d (Inches ³)	I _o (Inches ⁴)	A*y ² (Inches ⁴)	I _{total} (Inches ⁴)
Girder only:						
Top flange	6.840	55.188	377.5	0.3	6384.5	6384.8
Web	27.000	27.875	752.6	6561.0	283.3	6844.3
Bottom flange	12.250	0.438	5.4	0.6	7173.1	7173.7
Total	46.090	24.636	1135.5	6561.9	13840.9	20402.8
Deck Steel:						
Girder	46.090	24.636	1135.5	20402.8	3009.2	23412.0
Top Steel	6.386	63.438	405.1	0.0	6027.1	6027.1
Bottom Steel	6.386	60.313	385.2	0.0	4863.3	4863.3
Total	58.862	32.716	1925.7	20402.8	13899.7	34302.5
Composite (3n):						
Girder	46.090	24.636	1135.5	20402.8	11963.5	32366.3
Slab	34.333	62.375	2141.5	183.1	16060.1	16243.2
Total	80.423	40.747	3277.0	20585.9	28023.6	48609.5
Composite (n):						
Girder	46.090	24.636	1135.5	20402.8	31330.6	51733.3
Slab	103.000	62.375	6424.6	549.3	14019.7	14569.0
Total	149.090	50.708	7560.1	20952.1	45350.2	66302.3
Section	Y _{botmid} (Inches)	Y _{topmid} (Inches)		S _{botmid} (Inches ³)	S _{topmid} (Inches ³)	
Girder only	24.198	30.552		843.1	667.8	
Deck Steel	32.279	22.471		1062.7	1526.5	
Composite (3n)	40.309	14.441		1205.9	3366.2	
Composite (n)	50.271	4.479		1318.9	14802.1	

Table 4-3 Section Properties Using Effective Top Flange Area of Steel Girder

Section Properties - Effective Bottom Flange Area						
Section	Area, A (Inches ²)	Centroid, d (Inches)	A*d (Inches ³)	I _o (Inches ⁴)	A*y ² (Inches ⁴)	I _{total} (Inches ⁴)
Girder only:						
Top flange	8.750	55.188	482.9	0.3	6781.3	6781.6
Web	27.000	27.875	752.6	6561.0	7.5	6568.5
Bottom flange	9.580	0.438	4.2	0.6	6937.8	6938.5
Total	45.330	27.348	1239.7	6561.9	13726.7	20288.6
Deck Steel:						
Girder	45.330	27.348	1239.7	20288.6	2611.1	22899.7
Top Steel	6.386	63.438	405.1	0.0	5186.8	5186.8
Bottom Steel	6.386	60.313	385.2	0.0	4111.7	4111.7
Total	58.102	34.938	2030.0	20288.6	11909.6	32198.2
Composite (3n):						
Girder	45.330	27.348	1239.7	20288.6	10329.9	30618.4
Slab	34.333	62.375	2141.5	183.1	13638.4	13821.5
Total	79.663	42.444	3381.2	20471.7	23968.3	44440.0
Composite (n):						
Girder	45.330	27.348	1239.7	20288.6	26816.1	47104.7
Slab	103.000	62.375	6424.6	549.3	11801.7	12351.0
Total	148.330	51.671	7664.3	20837.9	38617.8	59455.7
Section	Y _{botmid} (Inches)	Y _{topmid} (Inches)		S _{botmid} (Inches ³)	S _{topmid} (Inches ³)	
Girder only	26.911	27.839		753.9	728.8	
Deck Steel	34.501	20.249		933.3	1590.1	
Composite (3n)	42.007	12.743		1057.9	3487.3	
Composite (n)	51.233	3.517		1160.5	16906.8	

Table 4-4 Section Properties Using Effective Bottom Flange Area of Steel Girder

Strength I Limit State Stresses - Dead Load + Positive Live Load:

The section properties for this case have been calculated in Tables 4-3 and 4-4. The stresses at the midthickness of the flanges are shown in Table 4-6, which immediately follows the sample calculation presented below.

A typical computation for the stresses occurring at the midthickness of the flanges is presented in the example below. The stress in the bottom flange of the girder is computed using the 3n-composite section for the composite dead load and future wearing surface, and the n-composite section for the live load:

$$f = \frac{M}{S}$$

Noncomposite DL:

Stress at the midthickness:

$$f = f_{\text{botgdr}_1}$$

Noncomposite DL Moment:

$$M_{\text{NDL}} = -51.8 \text{ K}\cdot\text{ft}$$

Section Modulus (girder only), from Table 4-3:

$$S_{\text{botgdr}_1} = 843.1 \cdot \text{in}^3$$

Stress due to the noncomposite dead load:

$$f_{\text{botgdr}_1} = \frac{M_{\text{NDL}}}{S_{\text{botgdr}_1}} \quad f_{\text{botgdr}_1} = -0.74 \text{ ksi}$$

Composite DL:

Stress at the midthickness:

$$f = f_{\text{botgdr}_2}$$

Composite DL Moment:

$$M_{\text{CDL}} = 15.5 \text{ K}\cdot\text{ft}$$

Section Modulus (3n-composite), From Table 4-4:

$$S_{\text{botgdr}_2} = 1057.9 \cdot \text{in}^3$$

Stress due to the composite dead load:

$$f_{\text{botgdr}_2} = \frac{M_{\text{CDL}}}{S_{\text{botgdr}_2}} \quad f_{\text{botgdr}_2} = 0.18 \text{ ksi}$$

Future Wearing Surface:

Stress at the midthickness:

$$f = f_{\text{botgdr}_3}$$

FWS Moment:

$$M_{\text{FWS}} = 18.8 \text{ K}\cdot\text{ft}$$

Section Modulus (3n-composite), From Table 4-4:

$$S_{\text{botgdr}_3} = 1057.9 \cdot \text{in}^3$$

Stress due to the composite dead load:

$$f_{\text{botgdr}_3} = \frac{M_{\text{FWS}}}{S_{\text{botgdr}_3}} \quad f_{\text{botgdr}_3} = 0.21 \text{ ksi}$$

Positive Live Load:

Stress at the midthickness:

$$f = f_{\text{botgdr}_4}$$

Live Load Moment:

$$M_{\text{PLL}} = 1307.8 \text{ K}\cdot\text{ft}$$

Section Modulus (n-composite), From Table 4-4:

$$S_{\text{botgdr}_4} = 1160.5 \cdot \text{in}^3$$

Stress due to the positive live load:

$$f_{\text{botgdr}_4} = \frac{M_{\text{PLL}}}{S_{\text{botgdr}_4}} \quad f_{\text{botgdr}_4} = 13.52 \text{ ksi}$$

The preceding stresses are now factored by their respective load factors to obtain the final factored stress at the midthickness of the bottom flange for this load case. The applicable load factors for this case were discussed previously.

$$f_{\text{botgdr}} = \left(0.90 \cdot f_{\text{botgdr}_1} + 0.90 \cdot f_{\text{botgdr}_2} + 1.50 \cdot f_{\text{botgdr}_3} + 1.75 \cdot f_{\text{botgdr}_4} \right)$$

$$f_{\text{botgdr}} = 23.48 \text{ ksi}$$

The stresses at the midthickness of the top flange for this load case are computed in a similar manner. The section properties used to obtain the stresses in the top flange are also from Tables 4-3 and 4-4.

STable 3.4.1-1
STable 3.4.1-2

The top and bottom flange midthickness stresses are summarized in Table 4-5, shown below.

Strength I - Dead Load + Positive Live Load			
Summary of Unfactored Values			
Loading	Moment (K-ft)	f_{botmid} (ksi)	f_{topmid} (ksi)
Noncomposite DL	-51.80	-0.74	0.93
Composite DL	15.50	0.18	-0.05
FWS DL	18.80	0.21	-0.06
Live Load - HL-93	1307.80	13.52	-0.93
Summary of Factored Values			
Limit State			
Strength I	2284.18	23.48	-0.93

Table 4-5 Strength I Flange Stresses for Dead + Pos. LL

The computation of the midthickness flange stresses for the remaining load cases are computed in a manner similar to what was shown in the sample calculation that preceded Table 4-5.

Strength I Limit State - Dead Load + Negative Live Load:

The computed stresses in the following table require the use of section properties from Table 4-3.

Strength I - Dead Load + Negative Live Load			
Summary of Unfactored Values			
Loading	Moment (K-ft)	f_{botmid} (ksi)	f_{topmid} (ksi)
Noncomposite DL	-51.80	-0.74	0.93
Composite DL	15.50	0.18	-0.12
Live Load - HL-93	-953.30	-10.76	7.49
Summary of Factored Values			
Limit State			
Strength I	-1713.65	-19.54	14.13

Table 4-6 Strength I Flange Stresses for Dead + Neg. LL

Service II Limit State - Dead Load + Positive Live Load:

The computed stresses in the following table require the use of section properties from Table 4-2.

Service II - Dead Load + Positive Live Load			
Summary of Unfactored Values			
Loading	Moment (K-ft)	f_{botmid} (ksi)	f_{topmid} (ksi)
Noncomposite DL	-51.80	-0.71	0.82
Composite DL	15.50	0.15	-0.05
FWS	18.80	0.19	-0.06
Live Load - HL-93	1307.80	11.91	-1.05
Summary of Factored Values			
Limit State			
Service II	1682.64	15.10	-0.65

Table 4-7 Service II Flange Stresses for Dead + Pos. LL

Service II Limit State - Dead Load + Negative Live Load:

The computed stresses in the following table require the use of section properties from Table 4-2.

Service II - Dead Load + Negative Live Load			
Summary of Unfactored Values			
Loading	Moment (K-ft)	f_{botmid} (ksi)	f_{topmid} (ksi)
Noncomposite DL	-51.80	-0.71	0.82
Composite DL	15.50	0.14	-0.01
Live Load - HL-93	-953.30	-8.68	0.76
Summary of Factored Values			
Limit State			
Service II	-1275.59	-11.85	1.80

Table 4-8 Service II Flange Stresses for Dead + Neg. LL

Fatigue Limit State - Positive Live Load:

The computed stresses in the following table require the use of section properties from Table 4-2.

Fatigue - Positive Live Load			
Summary of Unfactored Values			
Loading	Moment (K-ft)	f_{botmid} (ksi)	f_{topmid} (ksi)
Live Load-Fatigue	394.30	3.59	-0.32
Summary of Factored Values			
Limit State			
Fatigue	295.73	2.69	-0.24

Table 4-9 Fatigue Flange Stresses for Positive LL

Fatigue Limit State - Negative Live Load:

The computed stresses in the following table require the use of section properties from Table 4-2.

Fatigue - Negative Live Load			
Summary of Unfactored Values			
Loading	Moment (K-ft)	f_{botmid} (ksi)	f_{topmid} (ksi)
Live Load-Fatigue	-284.00	-2.59	0.23
Summary of Factored Values			
Limit State			
Fatigue	-213.00	-1.94	0.17

Table 4-10 Fatigue Flange Stresses for Negative LL

Fatigue Limit State:

The computed stresses in the following table require the use of section properties from Table 4-2.

Fatigue - Live Load			
Summary of Unfactored Values			
Loading	Moment (K-ft)	f_{botweb} (ksi)	f_{topweb} (ksi)
Live Load-Pos	394.3	3.56	-0.29
Live Load-Neg	-284.00	-2.56	0.21
Summary of Factored Values			
Limit State			
Pos Fatigue	295.73	2.67	-0.22
Neg Fatigue	-213.00	-1.92	0.16

Table 4-11 Fatigue Web Stresses for Positive and Negative Live Load

A summary of the factored stresses at the midthickness of the top and bottom flanges for the Strength I, Service II, and Fatigue limit states are presented below in Tables 4-12 through 4-14. Table 4-14 also contains the top and bottom web fatigue stresses.

Limit State	Location	Stress (ksi)	
		Dead + Pos. LL	Dead + Neg. LL
Strength I	Bottom Flange	23.48	-19.54
	Top Flange	-0.93	14.13

Table 4-12 Strength I Flange Stresses

Limit State	Location	Stress (ksi)	
		Dead + Pos. LL	Dead + Neg. LL
Service II	Bottom Flange	15.10	-11.85
	Top Flange	-0.65	1.80

Table 4-13 Service II Flange Stresses

Limit State	Location	Stress (ksi)	
		Positive LL	Negative LL
Fatigue	Bottom Flange	2.69	-1.94
	Top Flange	-0.24	0.17
	Bottom of Web	2.67	-1.92
	Top of Web	-0.22	0.16

Table 4-14 Fatigue Flange and Web Stresses

Strength I Minimum Design Force - Controlling Flange:

S6.13.6.1.4c

The next step is to determine the minimum design forces for the controlling flange of each load case (i.e., positive and negative live load). By inspection of Table 4-12, it is obvious that the bottom flange is the controlling flange for both positive and negative live load for the Strength I Limit State.

The minimum design force for the controlling flange, P_{cu} , is taken equal to the design stress, F_{cf} , times the smaller effective flange area, A_e , on either side of the splice. When a flange is in compression, the effective compression flange area shall be taken as $A_e = A_g$.

S6.10.3.6

The calculation of the minimum design force is presented below for the load case of dead load with positive live load.

The minimum design stress for the controlling (bottom) flange is computed as follows:

$$F_{cf} = \frac{\left(\left| \frac{f_{cf}}{R_h} \right| + \alpha \cdot \phi_f \cdot F_{yf} \right)}{2} \geq 0.75 \cdot \alpha \cdot \phi_f \cdot F_{yf}$$

SEquation
6.13.6.1.4c-1

where:

Maximum flexural stress due to the factored loads at the midthickness of the controlling flange at the point of splice (from Table 4-12): $f_{cf} = 23.48 \cdot \text{ksi}$

Hybrid girder reduction factor. For homogeneous girders: $R_h = 1.0$

Flange stress reduction factor: $\alpha = 1.0$

Resistance factor for flexure (Design Step 4.1): $\phi_f = 1.0$

Minimum yield strength of the flange: $F_{yf} = 50 \text{ ksi}$

$$F_{cf_1} = \frac{\left(\left| \frac{f_{cf}}{R_h} \right| + \alpha \cdot \phi_f \cdot F_{yf} \right)}{2}$$

$$F_{cf_1} = 36.74 \text{ ksi}$$

Compute the minimum required design stress:

$$F_{cf_2} = 0.75 \cdot \alpha \cdot \phi_f \cdot F_{yf}$$

$$F_{cf_2} = 37.50 \text{ ksi}$$

The minimum design stress for the bottom flange for this load case is:

$$F_{cf} = \max(F_{cf_1}, F_{cf_2})$$

$$F_{cf} = 37.50 \text{ ksi}$$

The minimum design force now follows:

$$P_{cu} = F_{cf} \cdot A_e$$

The gross area of the bottom flange is:

$$A_{fibL} = b_{fibL} \cdot t_{fibL}$$

$$A_{fibL} = 12.25 \text{ in}^2$$

Since the bottom flange force for this load case is a tensile force, the effective area will be used. This value was computed previously to be:

$$A_{\text{ebot}} = 9.58 \text{ in}^2$$

Therefore:

$$P_{\text{cu}} = F_{\text{cf}} \cdot A_{\text{ebot}}$$

$$P_{\text{cu}} = 359.25 \text{ K}$$

Table 4-15 presents the minimum design forces for the Strength I Limit State for both the positive and negative live load cases.

		Strength I Limit State			
		Controlling Flange			
Load Case	Location	f_{cf} (ksi)	F_{cf} (ksi)	Area (in ²)	P_{cu} (kips)
Dead + Pos. LL	Bot. Flange	23.48	37.5	9.58	359.25
Dead + Neg. LL	Bot. Flange	-19.54	37.5	12.25	459.38

Table 4-15 Controlling Flange Forces

In the above table, the design controlling flange force (P_{cu}) is a compressive force for negative live load.

Strength I Minimum Design Force - Noncontrolling Flange:

S6.13.6.1.4c

The next step is to determine the minimum design forces for the noncontrolling flange of each load case (i.e., positive and negative live load). By inspection of Table 4-12, the top flange is the noncontrolling flange for both positive and negative live load for the Strength I Limit State.

The minimum design force for the noncontrolling flange, P_{ncu} , is taken equal to the design stress, F_{ncf} , times the smaller effective flange area, A_e , on either side of the splice. When a flange is in compression, the effective compression flange area shall be taken as $A_e = A_g$.

S6.10.3.6

The calculation of the minimum design force is presented below for the load case of dead load with positive live load.

The minimum design stress for the noncontrolling (top) flange is computed as follows:

$$F_{ncf} = R_{cf} \cdot \left| \frac{f_{ncf}}{R_h} \right| \geq 0.75 \cdot \alpha \cdot \phi_f \cdot F_{yf}$$

SEquation
6.13.6.1.4c-2

where:

Maximum flexural stress due to the factored loads at the midthickness of the noncontrolling flange at the point of splice concurrent with f_{cf} (see Table 4-12):

$$f_{ncf} = -0.93 \text{ ksi}$$

Controlling flange design stress:

$$F_{cf} = 37.50 \text{ ksi}$$

Controlling flange actual stress:

$$f_{cf} = 23.48 \text{ ksi}$$

Controlling flange stress ratio:

$$R_{cf} = \left| \frac{F_{cf}}{f_{cf}} \right| \quad R_{cf} = 1.60$$

Hybrid girder reduction factor:

$$R_h = 1.00$$

Therefore:

$$F_{ncf_1} = R_{cf} \cdot \left| \frac{f_{ncf}}{R_h} \right|$$

$$F_{ncf_1} = 1.49 \text{ ksi}$$

Compute the minimum required design stress:

$$F_{ncf_2} = 0.75 \cdot \alpha \cdot \phi_f \cdot F_{yf}$$

$$F_{ncf_2} = 37.50 \text{ ksi}$$

The minimum design stress in the top flange is:

$$F_{ncf} = \max(F_{ncf_1}, F_{ncf_2})$$

$$F_{ncf} = 37.50 \text{ ksi}$$

The minimum design force now follows:

$$P_{ncu} = F_{ncf} \cdot A_e$$

For the positive live load case, the top flange is in compression.
The effective compression flange area shall be taken as:

$$A_e = A_g$$

$$A_g = t_{ftL} \cdot b_{ftL} \qquad A_g = 8.75 \text{ in}^2$$

Therefore:

$$P_{ncu} = F_{ncf} \cdot A_g$$

$$P_{ncu} = 328.13 \text{ K} \quad (\text{compression})$$

SEquation
6.10.3.6-2

Table 4-16 presents the minimum design forces for the Strength I Limit State for both the positive and negative live load cases.

		Strength I Limit State Noncontrolling Flange			
Load Case	Location	f_{ncf} (ksi)	F_{ncf} (ksi)	Area (in ²)	P_{ncu} (kips)
Dead + Pos. LL	Top Flange	-0.93	37.5	8.75	328.13
Dead + Neg. LL	Top Flange	14.13	37.5	6.84	256.50

Table 4-16 Noncontrolling Flange Forces

In the above table, the design noncontrolling flange force (P_{ncu}) is a compressive force for positive live load.

Service II Limit State Flange Forces:

S6.13.6.1.4c

Per the Specifications, bolted connections for flange splices are to be designed as slip-critical connections for the service level flange design force. This design force shall be taken as the Service II design stress, F_s , multiplied by the smaller gross flange area on either side of the splice.

F_s is defined as follows:

$$F_s = \frac{f_s}{R_h}$$

SEquation
6.13.6.1.4c-4

f_s = maximum flexural Service II stress at the midthickness of the flange under consideration.

The factored Service II design stresses and forces are shown in Table 4-17 below.

		Service II Limit State		
Load Case	Location	F_s (ksi)	A_{gross} (in ²)	P_s (kips)
Dead + Pos. LL	Bot. Flange	15.10	12.25	184.98
	Top Flange	-0.65	8.75	-5.69
Dead + Neg. LL	Bot. Flange	-11.85	12.25	-145.16
	Top Flange	1.80	8.75	15.75

Table 4-17 Service II Flange Forces

It is important to note here that the flange slip resistance must exceed the larger of: (1) the Service II flange forces or (2) the factored flange forces from the moments at the splice due to constructibility (erection and/or deck pouring sequence). However, in this design example, no special erection procedure is prescribed and, per the Introduction in Design Step 1, the deck is placed in a single pour. Therefore, the constructibility moment is equal to the noncomposite dead load moment shown at the beginning of this design step. By inspection, the Service II Limit State will control for checking of slip-critical connections for the flanges and the web in this example.

S3.4.2

Fatigue Limit State Stresses:

C6.13.6.1.4c

The final portion of this design step is to determine the range of the stresses at the midthickness of both flanges, and at the top and bottom of the web for the Fatigue Limit State. The ranges are calculated below and presented in Table 4-18.

A typical calculation of the stress range for the bottom flange is shown below.

From Tables 4-9 and 4-10, the factored stresses at the midthickness of the bottom flange are:

Case 1 - Positive Live Load:

$$f_{spos} = 2.69 \cdot \text{ksi}$$

Case 2 - Negative Live Load:

$$f_{sneg} = -1.94 \cdot \text{ksi}$$

The stress range is determined by:

$$\Delta f = |f_{spos}| + |f_{sneg}|$$

$$\Delta f = 4.63 \text{ ksi}$$

Fatigue Limit State Stress Range (ksi)	
Location	Δf (ksi)
Bottom Flange	4.63
Top Flange	0.41
Bottom of Web	4.59
Top of Web	0.38

Table 4-18 Fatigue Stress Ranges

Design Step 4.4 - Design Bottom Flange Splice

Splice Plate Dimensions:

The width of the outside plate should be at least as wide as the width of the narrowest flange at the splice. Therefore, try a 7/16" x 14" outside splice plate with two 1/2" x 6" inside splice plates. Include a 1/2" x 14" fill plate on the outside. Figure 4-3 illustrates the initial bottom flange splice configuration.

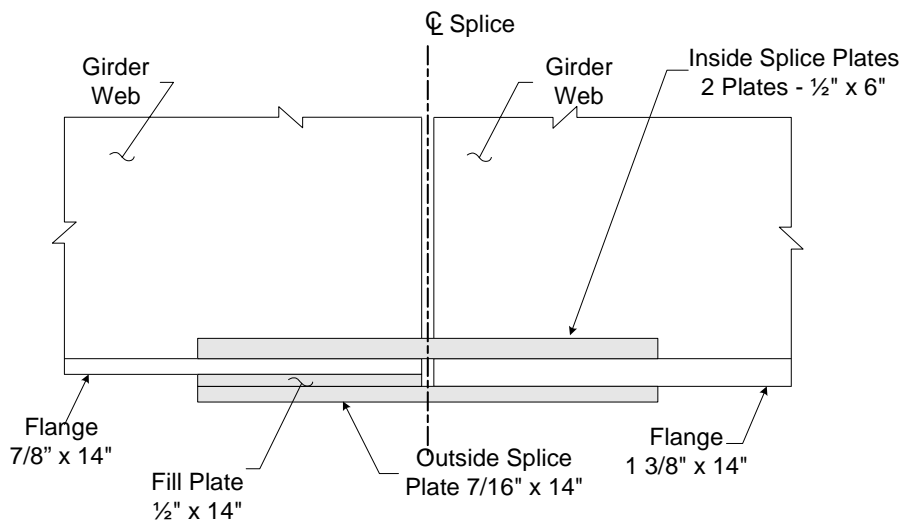

Figure 4-3 Bottom Flange Splice

The dimensions of the elements involved in the bottom flange splice from Figure 4-3 are:

Thickness of the inside splice plate: $t_{in} = 0.50 \cdot \text{in}$

Width of the inside splice plate: $b_{in} = 6 \cdot \text{in}$

Thickness of the outside splice plate: $t_{out} = 0.4375 \cdot \text{in}$

Width of the outside splice plate: $b_{out} = 14 \cdot \text{in}$

Thickness of the fill plate: $t_{fill} = 0.50 \cdot \text{in}$

Width of the fill plate: $b_{fill} = 14 \cdot \text{in}$

If the combined area of the inside splice plates is within ten percent of the area of the outside splice plate, then both the inside and outside splice plates may be designed for one-half the flange design force.

Gross area of the inside and outside splice plates:

Inside:

$$A_{\text{gross_in}} = 2 \cdot t_{\text{in}} \cdot b_{\text{in}}$$

$$A_{\text{gross_in}} = 6.00 \text{ in}^2$$

Outside:

$$A_{\text{gross_out}} = t_{\text{out}} \cdot b_{\text{out}}$$

$$A_{\text{gross_out}} = 6.13 \text{ in}^2$$

Check:

$$\left(1 - \frac{A_{\text{gross_in}}}{A_{\text{gross_out}}} \right) \cdot 100\% = 2.04\%$$

The combined areas are within ten percent.

If the areas of the inside and outside splice plates had differed by more than ten percent, the flange design force would be proportioned to the inside and outside splice plates. This is calculated by multiplying the flange design force by the ratio of the area of the splice plate under consideration to the total area of the inner and outer splice plates.

C6.13.6.1.4c

C6.13.6.1.4c

Yielding and Fracture of Splice Plates:

S6.13.6.1.4c

Case 1 - Tension:

S6.13.5.2

At the Strength Limit State, the design force in the splice plates subjected to tension shall not exceed the factored resistances for yielding, fracture, and block shear.

From Table 4-15, the Strength I bottom flange tension design force is:

$$P_{cu} = 359.25 \text{ K}$$

The factored tensile resistance for yielding on the gross section is:

$$P_r = \phi_y \cdot P_{ny}$$

$$P_r = \phi_y \cdot F_y \cdot A_g$$

$$F_y = 50 \text{ ksi} \quad (\text{Design Step 4.1})$$

$$\phi_y = 0.95 \quad (\text{Design Step 4.1})$$

SEquation
6.8.2.1-1

For yielding of the outside splice plate:

$$A_g = A_{\text{gross_out}}$$

$$P_r = \phi_y \cdot F_y \cdot A_g$$

$$P_r = 290.94 \text{ K}$$

The outside splice plate takes half of the design load:

$$\frac{P_{cu}}{2} = 179.63 \text{ K}$$

$$P_r = 290.94 \text{ K} > \frac{P_{cu}}{2} = 179.63 \text{ K} \quad \text{OK}$$

For yielding of the inside splice plates:

$$A_g = A_{\text{gross_in}}$$

$$P_r = \phi_y \cdot F_y \cdot A_g$$

$$P_r = 285.00 \text{ K}$$

The inside splice plate takes half of the design load:

$$\frac{P_{\text{cu}}}{2} = 179.63 \text{ K}$$

$$P_r = 285.00 \text{ K} > \frac{P_{\text{cu}}}{2} = 179.63 \text{ K} \quad \text{OK}$$

The factored tensile resistance for fracture on the net section is:

$$P_r = \phi_U \cdot P_{\text{nu}}$$

$$P_r = \phi_U \cdot F_u \cdot A_n \cdot U$$

$$F_u = 65 \text{ ksi} \quad (\text{Design Step 4.1})$$

$$\phi_U = 0.80 \quad (\text{Design Step 4.1})$$

$$U = 1.0$$

To compute the net area of the splice plates, assume four 7/8" bolts across the width of the splice plate.

The net width shall be determined for each chain of holes extending across the member along any transverse, diagonal or zigzag line. This is determined by subtracting from the width of the element the sum of the width of all holes in the chain and adding the quantity $s^2/4g$ for each space between consecutive holes in the chain. For non-staggered holes, such as in this design example, the minimum net width is the width of the element minus the number of bolt holes in a line straight across the width.

SEquation
6.8.2.1-2

S6.13.5.2

S6.8.3

For fracture of the outside splice plate:

The net width is:

$$b_{n_out} = b_{out} - 4 \cdot d_{hole}$$

$$d_{hole} = 1.0 \text{ in} \quad (\text{Design Step 4.1})$$

$$b_{n_out} = 10.00 \text{ in}$$

The nominal area is determined to be:

$$A_{n_out} = b_{n_out} \cdot t_{out}$$

$$A_{n_out} = 4.38 \text{ in}^2$$

The net area of the connecting element is limited to $0.85 A_g$:

S6.13.5.2

$$A_n \leq 0.85 \cdot A_g$$

$$A_{gross_out} = 6.13 \text{ in}^2$$

$$A_{n_out} = 4.38 \text{ in}^2 < 0.85 \cdot A_{gross_out} = 5.21 \text{ in}^2 \quad \text{OK}$$

$$P_r = \phi_U \cdot F_U \cdot A_{n_out} \cdot U$$

$$P_r = 227.50 \text{ K}$$

The outside splice plate takes half of the design flange force:

$$P_r = 227.50 \text{ K} > \frac{P_{cu}}{2} = 179.63 \text{ K} \quad \text{OK}$$

For fracture of the inside splice plates:

The net width is:

$$b_{n_in} = b_{in} - 2 \cdot d_{hole}$$

$$b_{n_in} = 4.00 \text{ in}$$

The nominal area is determined to be:

$$A_{n_in} = 2(b_{n_in} \cdot t_{in})$$

$$A_{n_in} = 4.00 \text{ in}^2$$

The net area of the connecting element is limited to $0.85 A_g$:

S6.13.5.2

$$A_n \leq 0.85 \cdot A_g$$

$$A_{gross_in} = 6.00 \text{ in}^2$$

$$A_{n_in} = 4.00 \text{ in}^2 < 0.85 \cdot A_{gross_in} = 5.10 \text{ in}^2 \quad \text{OK}$$

$$P_r = \phi_u \cdot F_u \cdot A_{n_in} \cdot U$$

$$P_r = 208.00 \text{ K}$$

The inside splice plates take half of the design flange force:

$$P_r = 208.00 \text{ K} > \frac{P_{cu}}{2} = 179.63 \text{ K} \quad \text{OK}$$

Case 2 - Compression:

S6.13.6.1.4c

From Table 4-15, the Strength I bottom flange compression design force is:

$$P_{cu} = 459.38 \cdot K$$

This force is distributed equally to the inside and outside splice plates.

The factored resistance of the splice plate is:

$$R_r = \phi_c \cdot F_y \cdot A_s$$

$$\phi_c = 0.90 \quad (\text{Design Step 4.1})$$

SEquation
6.13.6.1.4c-3

For yielding of the outside splice plate:

$$A_s = A_{\text{gross_out}}$$

$$R_{r_out} = \phi_c \cdot F_y \cdot A_s$$

$$R_{r_out} = 275.63 \text{ K}$$

$$R_{r_out} = 275.63 \text{ K} > \frac{P_{cu}}{2} = 229.69 \text{ K} \quad \text{OK}$$

For yielding of the inside splice plates:

$$A_s = A_{\text{gross_in}}$$

$$R_{r_in} = \phi_c \cdot F_y \cdot A_s$$

$$R_{r_in} = 270.00 \text{ K}$$

$$R_{r_in} = 270.00 \text{ K} > \frac{P_{cu}}{2} = 229.69 \text{ K} \quad \text{OK}$$

Block Shear:

All tension connections, including connection plates, splice plates and gusset plates, shall be investigated to ensure that adequate connection material is provided to develop the factored resistance of the connection. Block shear rupture will usually not govern the design of splice plates of typical proportion. However, the block shear checks are carried out here for completeness.

From Table 4-15, the Strength I bottom flange tension design force is:

$$P_{cu} = 359.25 \cdot K$$

To determine the appropriate block shear equation:

If $A_{tn} \geq 0.58 \cdot A_{vn}$ then:

$$R_r = \phi_{bs} \cdot (0.58 \cdot F_y \cdot A_{vg} + F_u \cdot A_{tn})$$

SEquation 6.13.4-1

Otherwise:

$$R_r = \phi_{bs} \cdot (0.58 \cdot F_u \cdot A_{vn} + F_y \cdot A_{tg})$$

SEquation 6.13.4-2

where, from Design Step 4.1:

Minimum yield strength of the connected material:

$$F_y = 50 \text{ ksi}$$

Minimum tensile strength of the connected material:

$$F_u = 65 \text{ ksi}$$

Resistance factor for block shear:

$$\phi_{bs} = 0.80$$

S6.13.6.1.4c

S6.13.5.2

S6.13.4

Outside Splice Plate:

Failure Mode 1:

A bolt pattern must be assumed prior to checking an assumed block shear failure mode. An initial bolt pattern for the bottom flange splice, along with the first assumed failure mode, is shown in Figure 4-4. The outside splice plate will now be checked for block shear.

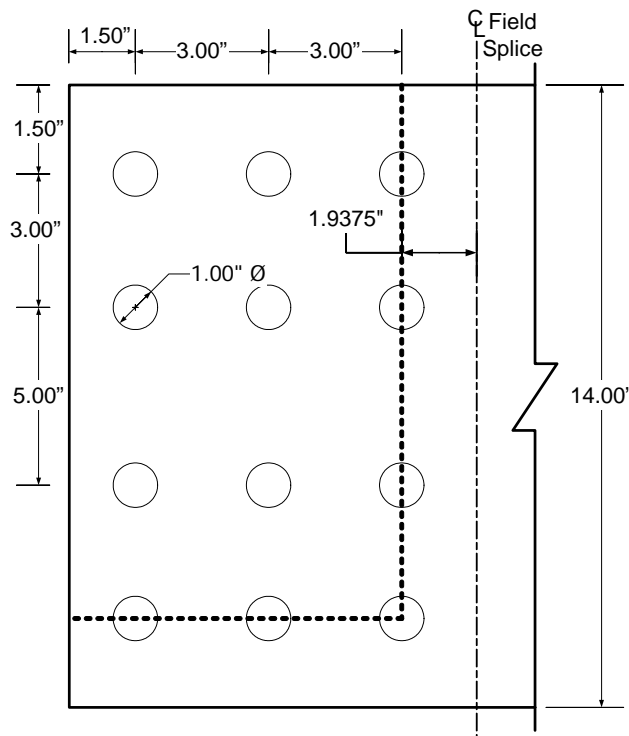

Figure 4-4 Outside Splice Plate - Failure Mode 1

Applying the factored resistance equations presented previously to the outside splice plate for Failure Mode 1:

Gross area along the plane resisting shear stress:

$$A_{vg} = [2 \cdot (3.00 \cdot \text{in}) + 1.50 \cdot \text{in}] \cdot t_{\text{out}}$$

$$A_{vg} = 3.28 \text{ in}^2$$

Net area along the plane resisting shear stress:

$$A_{vn} = [2 \cdot (3.00 \cdot \text{in}) + 1.50 \cdot \text{in} - 2.5 \cdot d_{\text{hole}}] \cdot t_{\text{out}}$$

$$A_{vn} = 2.19 \text{ in}^2$$

Gross area along the plane resisting tension stress:

$$A_{tg} = [2 \cdot (3.00 \cdot \text{in}) + 5.00 \cdot \text{in} + 1.50 \cdot \text{in}] \cdot t_{out}$$

$$A_{tg} = 5.47 \text{ in}^2$$

Net area along the plane resisting tension stress:

$$A_{tn} = [[2 \cdot (3.00 \cdot \text{in}) + 5.00 \cdot \text{in} + 1.50 \cdot \text{in}] - 3.5 \cdot d_{hole}] \cdot t_{out}$$

$$A_{tn} = 3.94 \text{ in}^2$$

To determine which equation should be applied to calculate the factored resistance:

$$A_{tn} = 3.94 \text{ in}^2 > 0.58 \cdot A_{vg} = 1.27 \text{ in}^2$$

Therefore, use *SEquation 6.13.4-1*:

$$R_r = \phi_{bs} \cdot (0.58 \cdot F_y \cdot A_{vg} + F_u \cdot A_{tn})$$

$$R_r = 280.88 \text{ K}$$

Check:

$$R_r = 280.88 \text{ K} > \frac{P_{cu}}{2} = 179.63 \text{ K} \quad \text{OK}$$

Failure Mode 2:

See Figure 4-5 for Failure Mode 2:

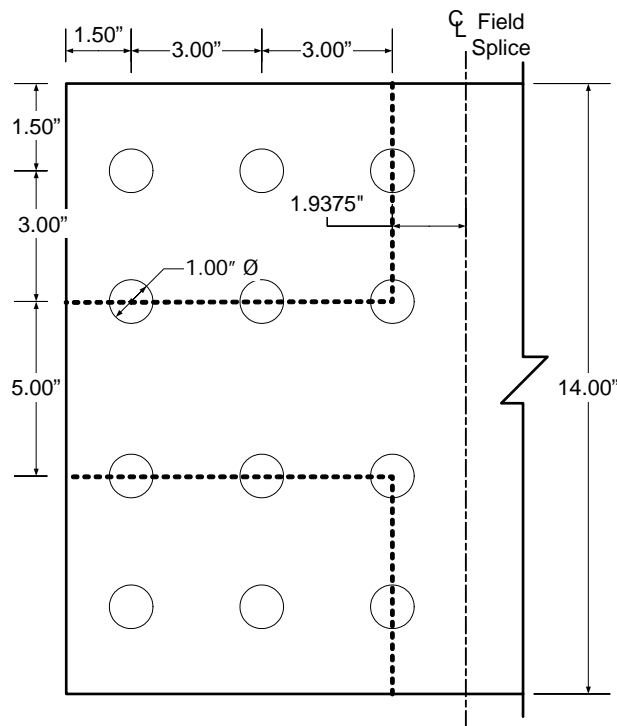

Figure 4-5 Outside Splice Plate - Failure Mode 2

Applying the factored resistance equations presented previously to the outside splice plate for Failure Mode 2:

Gross area along the plane resisting shear stress:

$$A_{vg} = 2[2 \cdot (3.00 \cdot \text{in}) + 1.50 \cdot \text{in}] \cdot t_{\text{out}}$$

$$A_{vg} = 6.56 \text{ in}^2$$

Net area along the plane resisting shear stress:

$$A_{vn} = 2[2 \cdot (3.00 \cdot \text{in}) + 1.50 \cdot \text{in} - 2.5 \cdot d_{\text{hole}}] \cdot t_{\text{out}}$$

$$A_{vn} = 4.38 \text{ in}^2$$

Gross area along the plane resisting tension stress:

$$A_{tg} = 2(3.00 \cdot \text{in} + 1.50 \cdot \text{in}) \cdot t_{out}$$

$$A_{tg} = 3.94 \text{ in}^2$$

Net area along the plane resisting tension stress:

$$A_{tn} = 2[(3.00 \cdot \text{in} + 1.50 \cdot \text{in}) - 1.5d_{hole}] \cdot t_{out}$$

$$A_{tn} = 2.63 \text{ in}^2$$

To determine which equation should be applied to calculate the factored resistance:

$$A_{tn} = 2.63 \text{ in}^2 > 0.58 \cdot A_{vn} = 2.54 \text{ in}^2$$

Therefore, use *SEquation 6.13.4-1*:

$$R_r = \phi_{bs} \cdot (0.58 \cdot F_y \cdot A_{vg} + F_u \cdot A_{tn})$$

$$R_r = 288.75 \text{ K}$$

Check:

$$R_r = 288.75 \text{ K} > \frac{P_{cu}}{2} = 179.63 \text{ K} \quad \text{OK}$$

Inside Splice Plates:

The inside splice plates will now be checked for block shear. See Figure 4-6 for the assumed failure mode:

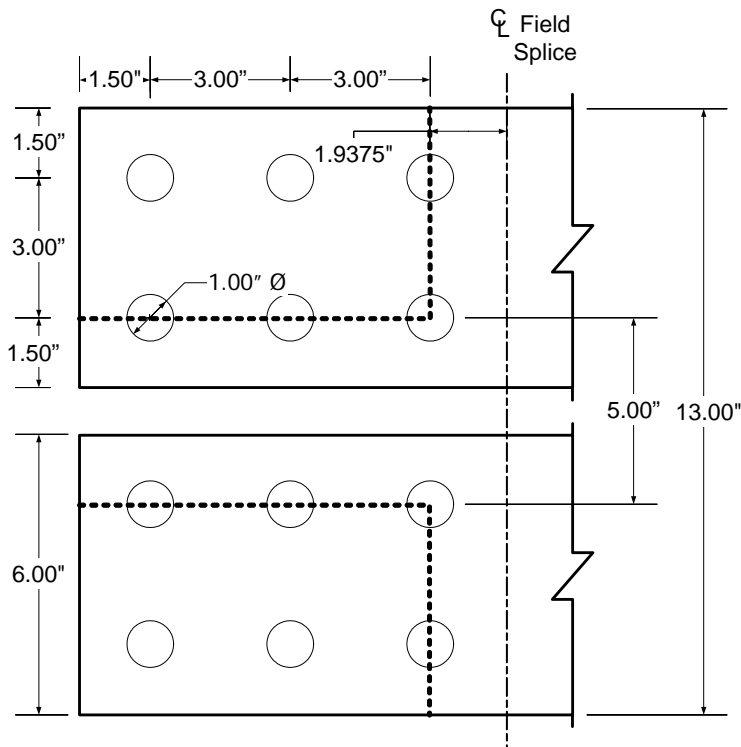

Figure 4-6 Inside Splice Plates - Block Shear Check

Applying the factored resistance equations presented previously to the inside splice plates for the assumed failure mode:

Gross area along the plane resisting shear stress:

$$A_{vg} = 2[2 \cdot (3.00 \cdot \text{in}) + 1.50 \cdot \text{in}] \cdot t_{in}$$

$$A_{vg} = 7.50 \text{ in}^2$$

Net area along the plane resisting shear stress:

$$A_{vn} = 2[[2 \cdot (3.00 \cdot \text{in}) + 1.50 \cdot \text{in}] - 2.5 \cdot d_{\text{hole}}] \cdot t_{in}$$

$$A_{vn} = 5.0 \text{ in}^2$$

Gross area along the plane resisting tension stress:

$$A_{tg} = 2(3.00 \cdot \text{in} + 1.50 \cdot \text{in}) \cdot t_{in}$$

$$A_{tg} = 4.50 \text{ in}^2$$

Net area along the plane resisting tension stress:

$$A_{tn} = 2[(3.00 \cdot \text{in} + 1.50 \cdot \text{in}) - 1.5d_{\text{hole}}] \cdot t_{in}$$

$$A_{tn} = 3.00 \text{ in}^2$$

To determine which equation should be applied to calculate the factored resistance:

$$A_{tn} = 3.0 \text{ in}^2 > 0.58 \cdot A_{vg} = 2.90 \text{ in}^2$$

Therefore, use *SEquation 6.13.4-1*:

$$R_r = \phi_{bs} \cdot (0.58 \cdot F_y \cdot A_{vg} + F_u \cdot A_{tn})$$

$$R_r = 330.00 \text{ K}$$

Check:

$$R_r = 330.00 \text{ K} > \frac{P_{cu}}{2} = 179.63 \text{ K} \quad \text{OK}$$

Girder Bottom Flange:

The girder bottom flange will now be checked for block shear. See Figure 4-7 for the assumed failure mode:

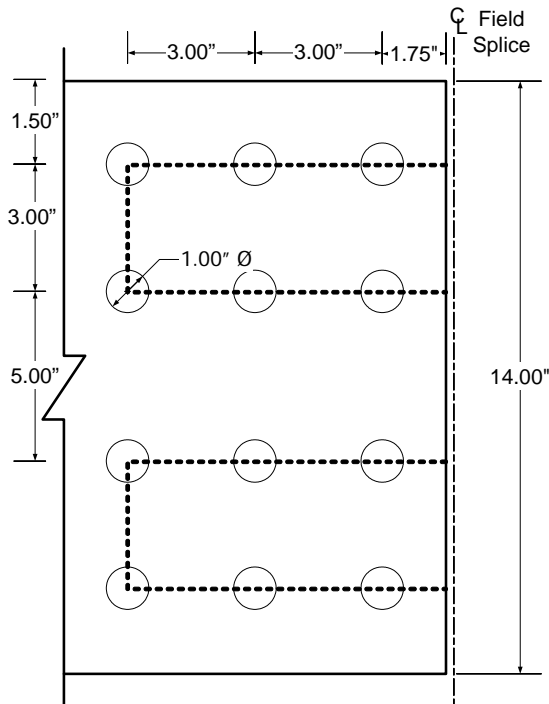

Figure 4-7 Bottom Flange - Block Shear Check

Applying the factored resistance equations presented previously to the bottom flange for the assumed failure mode:

Gross area along the plane resisting shear stress:

$$A_{vg} = 4[2 \cdot (3.00 \cdot \text{in}) + 1.75 \cdot \text{in}] \cdot t_{flbL}$$

$$A_{vg} = 27.13 \text{ in}^2$$

Net area along the plane resisting shear stress:

$$A_{vn} = 4[2 \cdot (3.00 \cdot \text{in}) + 1.75 \cdot \text{in}] - 2.5 \cdot d_{\text{hole}}] \cdot t_{flbL}$$

$$A_{vn} = 18.38 \text{ in}^2$$

Gross area along the plane resisting tension stress:

$$A_{tg} = 2(3.00 \cdot \text{in}) \cdot t_{flb}L$$

$$A_{tg} = 5.25 \text{ in}^2$$

Net area along the plane resisting tension stress:

$$A_{tn} = 2[(3.00 \cdot \text{in}) - 1.0d_{\text{hole}}] \cdot t_{flb}L$$

$$A_{tn} = 3.50 \text{ in}^2$$

To determine which equation should be applied to calculate the factored resistance:

$$A_{tn} = 3.50 \text{ in}^2 < 0.58 \cdot A_{vn} = 10.66 \text{ in}^2$$

Therefore, use *SEquation 6.13.4-2*:

$$R_r = \phi_{bs} \cdot (0.58 \cdot F_u \cdot A_{vn} + F_y \cdot A_{tg})$$

$$R_r = 764.19 \text{ K}$$

Check:

$$R_r = 764.19 \text{ K} > P_{cu} = 359.25 \text{ K} \quad \text{OK}$$

It should be noted that although the block shear checks performed in this design example indicate an overdesign, the number of bolts cannot be reduced prior to checking shear on the bolts and bearing at the bolt holes. These checks are performed in what follows.

Flange Bolts - Shear:

Determine the number of bolts for the bottom flange splice plates that are required to develop the Strength I design force in the flange in shear assuming the bolts in the connection have slipped and gone into bearing. A minimum of two rows of bolts should be provided to ensure proper alignment and stability of the girder during construction.

The Strength I flange design force used in this check was previously computed (reference Table 4-15):

$$P_{cu} = 459.38 \cdot K$$

The factored resistance of an ASTM A325 7/8" diameter high-strength bolt in shear must be determined, assuming the threads are excluded from the shear planes. For this case, the number of bolts required to provide adequate shear strength is determined by assuming the design force acts on two shear planes, known as double shear.

The nominal shear resistance is computed first as follows:

$$R_n = (0.48 \cdot A_b \cdot F_{ub} \cdot N_s)$$

*SEquation
6.13.2.7-1*

where:

Area of the bolt corresponding to the nominal diameter:

$$A_b = \frac{\pi}{4} \cdot d_{\text{bolt}}^2$$

$$A_b = 0.60 \text{ in}^2$$

Specified minimum tensile strength of the bolt from Design Step 4.1:

$$F_{ub} = F_{u\text{bolt}}$$

$$F_{ub} = 120 \text{ ksi}$$

Number of shear planes per bolt:

$$N_s = 2$$

$$R_n = 2 \cdot (0.48 \cdot A_b \cdot F_{ub})$$

$$R_n = 69.27 \text{ K}$$

The factored shear resistance now follows:

$$R_u = \phi_s \cdot R_n$$

$$\phi_s = 0.80 \quad (\text{Design Step 4.1})$$

$$R_u = 55.42 \text{ K}$$

When bolts carrying loads pass through fillers 0.25 inches or more in thickness in axially loaded connections, including girder flange splices, either:

S6.13.6.1.5

The fillers shall be extended beyond the gusset or splice material and shall be secured by enough additional bolts to distribute the total stress in the member uniformly over the combined section of the member and the filler.

or

The fillers need not be extended and developed provided that the factored resistance of the bolts in shear at the Strength Limit State, specified in Article 6.13.2.2, is reduced by an appropriate factor:

In this design example, the reduction factor approach will be used. The reduction factor per the Specifications is:

$$R = \left[\frac{(1 + \gamma)}{(1 + 2\gamma)} \right]$$

SEquation
6.13.6.1.5-1

where:

$$\gamma = \frac{A_f}{A_p}$$

Sum of the area of the fillers on the top and bottom of the connected plate:

$$A_f = b_{fill} t_{fill}$$

$$A_f = 7.00 \text{ in}^2$$

The smaller of either the connected plate area (i.e., girder flange) or the sum of the splice plate areas on the top and bottom of the connected plate determines A_p .

Bottom flange area:

$$b_{flbL} = 14 \text{ in}$$

$$t_{flbL} = 0.875 \text{ in}$$

$$A_{p1} = (b_{flbL}) \cdot (t_{flbL})$$

$$A_{p1} = 12.25 \text{ in}^2$$

Sum of splice plate areas is equal to the gross areas of the inside and outside splice plates:

$$A_{gross_in} = 6.00 \text{ in}^2$$

$$A_{gross_out} = 6.13 \text{ in}^2$$

$$A_{p2} = A_{gross_in} + A_{gross_out}$$

$$A_{p2} = 12.13 \text{ in}^2$$

The minimum of the areas is:

$$A_p = \min(A_{p1}, A_{p2})$$

$$A_p = 12.13 \text{ in}^2$$

Therefore:

$$\gamma = \frac{A_f}{A_p}$$

$$\gamma = 0.58$$

The reduction factor is determined to be:

$$R_{fill} = \left[\frac{(1 + \gamma)}{(1 + 2\gamma)} \right] \quad R_{fill} = 0.73$$

To determine the total number of bolts required for the bottom flange splice, divide the applied Strength I flange design force by the reduced allowable bolt shear strength:

$$R = R_u \cdot R_{fill}$$

$$R = 40.57K$$

The number of bolts required per side is:

$$N = \frac{P_{cu}}{R} \quad N = 11.32$$

The minimum number of bolts required on each side of the splice to resist the maximum Strength I flange design force in shear is twelve.

Flange Bolts - Slip Resistance:

Bolted connections for flange splices shall be designed as slip-critical connections for the Service II flange design force, or the flange design force from constructibility, whichever governs. In this design example, the Service II flange force controls (see previous discussion in Design Step 4.3).

S 6.13.6.1.4c

When checking for slip of the bolted connection for a flange splice with inner and outer splice plates, the slip resistance should always be determined by dividing the flange design force equally to the two slip planes regardless of the ratio of the splice plate areas. Slip of the connection cannot occur unless slip occurs on both planes.

C6.13.6.1.4c

From Table 4-17, the Service II bottom flange design force is:

$$P_s = 184.98 \cdot K$$

The factored resistance for slip-critical connections is:

$$R_r = R_n$$

$$R_n = K_h \cdot K_s \cdot N_s \cdot P_t$$

SEquation
6.13.2.2-1
SEquation
6.13.2.8-1

Determine the factored resistance per bolt assuming a Class B surface condition for the faying surface, standard holes (which are required per S6.13.6.1.4a) and two slip planes per bolt:

Class B surfaces are unpainted blast-cleaned surfaces and blast-cleaned surfaces with Class B coatings.

S6.13.2.8

Additionally:

Number of slip planes per bolt: $N_s = 2$

Minimum required bolt tension: $P_t = 39.0 \cdot K$

STable 6.13.2.8-1

Hole size factor: $K_h = 1.0$

STable 6.13.2.8-2

Surface condition factor for Class B surface conditions: $K_s = 0.50$

STable 6.13.2.8-3

$$R_r = K_h \cdot K_s \cdot N_s \cdot P_t \qquad R_r = 39.00K$$

The minimum number of bolts required to prevent slip is:

$$N = \frac{P_s}{R_r} \qquad N = 4.74$$

Use:

$N = 5$ bolts < $N = 12$ bolts determined previously to satisfy the bolt shear requirements.

Therefore, the number of bolts required for the bottom-flange splice is controlled by the bolt shear requirements. Arrange the bolts in three rows of four bolts per line with no stagger.



Friction Coefficient Selection

Weathering steel can be blasted for a Class B surface. Also, for painted steel, most inorganic zinc (IOZ) primers provide a Class B surface.

Flange Bolts - Minimum Spacing:

S6.13.2.6.1

The minimum spacing between centers of bolts in standard holes shall be no less than three times the diameter of the bolt.

$$d_{\text{bolt}} = 0.875 \text{ in} \quad (\text{Design Step 4.1})$$

$$s_{\text{min}} = 3 \cdot d_{\text{bolt}}$$

$$s_{\text{min}} = 2.63 \text{ in}$$

For this example, $s = 3.00 \text{ in}$ (see Figures 4-4 thru 4-7)

The minimum spacing requirement is satisfied.

Flange Bolts - Maximum Spacing for Sealing:

S6.13.2.6.2

The maximum spacing of the bolts is limited to prevent penetration of moisture in the joints.

For a single line adjacent to a free edge of an outside plate or shape (for example, the bolts along the edges of the plate parallel to the direction of the applied force):

$$s \leq (4.0 + 4.0 \cdot t) \leq 7.0$$

where:

Thickness of the thinner outside plate or shape:	$t_{\text{out}} = 0.4375 \text{ in}$
---	--------------------------------------

Maximum spacing for sealing:

$$4.0 \cdot \text{in} + 4.0 \cdot t_{\text{out}} = 5.75 \text{ in} \quad 5.75 \cdot \text{in} \leq 7.00 \cdot \text{in}$$

$$s \leq 5.75 \cdot \text{in} \quad \text{OK}$$

Next, check for sealing along the free edge at the end of the splice plate. The bolts are not staggered, therefore the applicable equation is:

$$s \leq (4.00 + 4.00 \cdot t) \leq 7.00$$

Maximum spacing along the free edge at the end of the splice plate (see Figures 4-4 thru 4-7):

$$s_{\text{end}} = 5.00 \cdot \text{in}$$

Maximum spacing for sealing:

$$4.00 \cdot \text{in} + 4.00 \cdot t_{\text{out}} = 5.75 \text{ in}$$

$$s_{\text{end}} \leq 5.75 \cdot \text{in} \quad \text{OK}$$

Therefore the requirement is satisfied.

Flange Bolts - Maximum Pitch for Stitch Bolts:

S6.13.2.6.3

The maximum pitch requirements are applicable only for mechanically fastened built-up members and will not be applied in this example.

Flange Bolts - Edge Distance:

S6.13.2.6.6

Minimum:

The minimum required edge distance is measured as the distance from the center of any bolt in a standard hole to an edge of the plate.

For a 7/8" diameter bolt measured to a sheared edge, the minimum edge distance is 1 1/2".

STable 6.13.2.6.6-1

Referring to Figures 4-4 thru 4-7, it is clear that the minimum edge distance specified for this example is 1 1/2" and thus satisfies the minimum requirement.

Maximum:

The maximum edge distance shall not be more than eight times the thickness of the thinnest outside plate or five inches.

$$8 \cdot t \leq 5.00 \cdot \text{in}$$

where:

$$t = t_{\text{out}}$$

$$t_{\text{out}} = 0.4375 \text{ in}$$

The maximum edge distance allowable is:

$$8 \cdot t_{\text{out}} = 3.50 \text{ in}$$

The maximum distance from the corner bolts to the corner of the splice plate or girder flange is equal to (reference Figure 4-7):

$$\sqrt{(1.50 \cdot \text{in})^2 + (1.75 \cdot \text{in})^2} = 2.30 \text{ in}$$

and satisfies the maximum edge distance requirement.

$$2.30 \cdot \text{in} \leq 3.50 \cdot \text{in} \quad \text{OK}$$

Flange Bolts - Bearing at Bolt Holes:

S6.13.2.9

Check bearing of the bolts on the connected material under the maximum Strength I Limit State design force. The maximum Strength I bottom flange design force from Table 4-15 is:

$$P_{cu} = 459.38 \cdot K$$

The design bearing strength of the connected material is calculated as the sum of the bearing strengths of the individual bolt holes parallel to the line of the applied force.

The element of the bottom flange splice that controls the bearing check in this design example is the outer splice plate.

To determine the applicable equation for the calculation of the nominal resistance, the clear distance between holes and the clear end distance must be calculated and compared to the value of two times the nominal diameter of the bolt. This check yields:

$$d_{\text{bolt}} = 0.875 \text{ in} \quad (\text{Design Step 4.1})$$

$$2 \cdot d_{\text{bolt}} = 1.75 \text{ in}$$

For the bolts adjacent to the end of the splice plate, the edge distance is 1 1/2". Therefore, the clear end distance between the edge of the hole and the end of the splice plate:

$$d_{\text{hole}} = 1.0 \text{ in} \quad (\text{Design Step 4.1})$$

$$L_{c_1} = 1.50 \cdot \text{in} - \frac{d_{\text{hole}}}{2}$$

$$L_{c_1} = 1.00 \text{ in}$$

The center-to-center distance between bolts in the direction of the force is three inches. Therefore, the clear distance between edges of adjacent holes is computed as:

$$L_{c_2} = 3.00 \cdot \text{in} - d_{\text{hole}}$$

$$L_{c_2} = 2.00 \text{ in}$$

For standard holes, where either the clear distance between holes or the clear end distance is less than twice the bolt diameter:

$$R_n = 1.2 \cdot L_c \cdot t \cdot F_u$$

SEquation
6.13.2.9-2

For the outside splice plate:

Thickness of the connected material: $t_{out} = 0.4375 \text{ in}$

Tensile strength of the connected material (Design Step 4.1): $F_u = 65 \text{ ksi}$

The nominal resistance for the end row of bolt holes is computed as follows:

$$R_{n_1} = 4 \cdot (1.2 \cdot L_{c_1} \cdot t_{out} \cdot F_u)$$

$$R_{n_1} = 136.50 \text{ K}$$

The nominal resistance for the remaining bolt holes is computed as follows:

$$R_{n_2} = 8 \cdot (1.2 \cdot L_{c_2} \cdot t_{out} \cdot F_u)$$

$$R_{n_2} = 546.00 \text{ K}$$

The total nominal resistance of the bolt holes is:

$$R_n = R_{n_1} + R_{n_2}$$

$$R_n = 682.50 \text{ K}$$

$$\phi_{bb} = 0.80 \quad (\text{Design Step 4.1})$$

$$R_r = \phi_{bb} \cdot R_n$$

$$R_r = 546.00 \text{ K}$$

Check:

$$\frac{P_{cu}}{2} = 229.69 \text{ K} < R_r = 546.00 \text{ K} \quad \text{OK}$$

Fatigue of Splice Plates:

S6.6.1

Check the fatigue stresses in the base metal of the bottom flange splice plates adjacent to the slip-critical connections. Fatigue normally does not govern the design of the splice plates, and therefore, an explicit check is not specified. However, a fatigue check of the splice plates is recommended whenever the combined area of the inside and outside flange splice plates is less than the area of the smaller flange at the splice.

From Table 4-18, the factored fatigue stress range at the midthickness of the bottom flange is:

$$\Delta f_{\text{fact}} = 4.63 \cdot \text{ksi}$$

For load-induced fatigue considerations, each detail shall satisfy:

$$\gamma \cdot (\Delta f) \leq (\Delta F)_n$$

SEquation
6.6.1.2.2-1

where:

Load factor for the fatigue load combination: $\gamma = 0.75$

Force effect, live load stress range due to the passage of the fatigue load:

$$\gamma(\Delta f) = \Delta f_{\text{fact}}$$

Nominal fatigue resistance: $(\Delta F)_n$

$$\Delta F_n = \left(\frac{A}{N}\right)^{\frac{1}{3}} \geq \frac{1}{2} \cdot \Delta F_{\text{TH}}$$

SEquation
6.6.1.2.5-1

The fatigue detail category under the condition of Mechanically Fastened Connections for checking the base metal at the gross section of high-strength bolted slip-resistant connections is Category B.

STable
6.6.1.2.3-1

The parameters required for the determination of the nominal fatigue resistance are as follows:

$$N = (365) \cdot (75) \cdot n \cdot (\text{ADTT})_{\text{SL}}$$

SEquation
6.6.1.2.5-2

For Fatigue Category B: $A = 120 \cdot 10^8$

STable
6.6.1.2.5-1

For a span length greater than 40.0 feet and at a location near the interior support, the number of stress range cycles per truck passage:

$$n = 1.5$$

STable
6.6.1.2.5-2

Single-lane ADTT, from Design Step 3.1:

$$\text{ADTT}_{\text{SL}} = 3000$$

Constant-amplitude fatigue threshold: $\Delta F_{\text{TH}} = 16 \cdot \text{ksi}$

STable
6.6.1.2.5-3

Therefore:

$$N = 123187500$$

Determine the nominal fatigue resistance:

Condition 1:

$$\Delta F_n = \left(\frac{A}{N} \right)^{\frac{1}{3}} \quad \Delta F_n = 4.60 \text{ ksi}$$

Condition 2:

$$\Delta F_n = \frac{1}{2} \cdot \Delta F_{\text{TH}} \quad \Delta F_n = 8.00 \text{ ksi} \quad (\text{governs})$$

Check that the following is satisfied:

$$\Delta f_{\text{fact}} \leq (\Delta F)_n$$

$$\Delta f_{\text{fact}} = 4.63 \text{ ksi} < \Delta F_n = 8.00 \text{ ksi} \quad \text{OK}$$

Control of Permanent Deflection - Splice Plates:

S6.10.5.2

A check of the flexural stresses in the splice plates at the Service II Limit State is not explicitly specified in the specifications. However, whenever the combined area of the inside and outside flange splice plates is less than the area of the smaller flange at the splice (which is the case for the bottom flange splice in this example), such a check is recommended.

The maximum Service II flange force in the bottom flange is taken from Table 4-17:

$$P_s = 184.98K$$

The following criteria will be used to make this check. The equation presented is for both steel flanges of composite section:

$$f_f \leq 0.95 \cdot F_{yf}$$

SEquation
6.10.5.2-1

where:

Elastic flange stress caused
by the factored loading: f_f

Specified minimum yield strength
of the flange (Design Step 4.1): $F_{yf} = 50 \text{ ksi}$

The flange force is equally distributed to the inner and outer splice plates due to the areas of the flanges being within 10 percent of each other:

$$P = \frac{P_s}{2} \quad P = 92.49K$$

The resulting stress in the outside splice plate is:

$$A_{\text{gross_out}} = 6.13 \text{ in}^2$$

$$f_{\text{out}} = \frac{P}{A_{\text{gross_out}}} \quad f_{\text{out}} = 15.10 \text{ ksi}$$

$$f_{\text{out}} = 15.10 \text{ ksi} < 0.95 \cdot F_{yf} = 47.50 \text{ ksi} \quad \text{OK}$$

The resulting stress in the inside splice plates is:

$$A_{\text{gross_in}} = 6.00 \text{ in}^2$$

$$f_{\text{in}} = \frac{P}{A_{\text{gross_in}}} \quad f_{\text{in}} = 15.42 \text{ ksi}$$

$$f_{\text{in}} = 15.42 \text{ ksi} < 0.95 \cdot F_{yf} = 47.50 \text{ ksi} \quad \text{OK}$$

Design Step 4.5 - Design Top Flange Splice

The design of the top flange splice is not included in this design example (for the sake of simplicity and brevity). However, the top flange splice is designed using the same procedures and methods presented in this design example for the bottom flange splice.

Design Step 4.6 - Compute Web Splice Design Loads

S6.13.6.1.4b

Web splice plates and their connections shall be designed for shear, the moment due to the eccentricity of the shear at the point of splice, and the portion of the flexural moment assumed to be resisted by the web at the point of the splice.

Girder Shear Forces at the Splice Location:

Based on the girder properties defined in Design Step 3 (Steel Girder Design), any number of commercially available software programs can be used to obtain the design dead and live loads at the splice. For this design example, the AASHTO Opis software was used. A summary of the unfactored shears at the splice from the initial trial of the girder design are listed below. The live loads include impact and distribution factors.

Loads**Shears**

Dead Loads:

Noncomposite:	$V_{NDL} = -60.8 \cdot K$
Composite:	$V_{CDL} = -8.7 \cdot K$
Future Wearing Surface:	$V_{FWS} = -10.6 \cdot K$

Live Loads:

HL-93 Positive:	$V_{PLL} = 14.5 \cdot K$
HL-93 Negative:	$V_{NLL} = -91.1 \cdot K$
Fatigue Positive:	$V_{PFLL} = 5.0 \cdot K$
Fatigue Negative:	$V_{NFLL} = -33.4 \cdot K$

Web Moments and Horizontal Force Resultant:

C6.13.6.1.4b

Because the portion of the flexural moment assumed to be resisted by the web is to be applied at the mid-depth of the web, a horizontal design force resultant, H_{UW} , must also be applied at the mid-depth of the web to maintain equilibrium. The web moment and horizontal force resultant are applied together to yield a combined stress distribution equivalent to the unsymmetrical stress distribution in the web. For sections with equal compressive and tensile stresses at the top and bottom of the web (i.e., with the neutral axis located at the mid-depth of the web), H_{UW} will equal zero.

In the computation of the portion of the flexural moment assumed to be resisted by the web, M_{UW} , and the horizontal design force resultant, H_{UW} , in the web, the flange stresses at the midthickness of the flanges are conservatively used. This allows use of the same stress values for both the flange and web splices, which simplifies the calculations. It is important to note that the flange stresses are taken as signed quantities in determining M_{UW} and H_{UW} (positive for tension; negative for compression).

C6.13.6.1.4b

The moment, M_{UV} , due to the eccentricity of the design shear, V_{UW} , is resisted solely by the web and always acts about the mid-depth of the web (i.e., horizontal force resultant is zero). This moment is computed as:

$$M_{UV} = V_{UW} \cdot e$$

where e is defined as the distance from the centerline of the splice to the centroid of the connection on the side of the joint under consideration. For this design example:

S6.13.6.1.4b

$$e = 1.9375 \cdot \text{in} + \frac{3.00 \cdot \text{in}}{2} \quad (\text{Reference Figure 4-8})$$

$$e = 3.44 \text{ in}$$

The total web moment for each load case is computed as follows:

$$M_{\text{total}} = M_{UW} + M_{UV}$$

In general, and in this example, the web splice is designed under the conservative assumption that the maximum moment and shear at the splice will occur under the same loading condition.

Strength I Limit State:*Design Shear:*

For the Strength I Limit State, the girder web factored shear resistance is required when determining the design shear. Assume an unstiffened web at the splice location.

$$\phi_v = 1.00 \quad (\text{Design Step 4.1})$$

$$V_r = \phi_v \cdot V_n$$

$$V_n = C \cdot V_p$$

$$V_p = 0.58 \cdot F_{yw} \cdot D \cdot t_w$$

where:

Ratio of shear buckling stress to the shear yield strength, C , is dependent upon the ratio of D/t_w in comparison to:

$$1.10 \cdot \sqrt{\frac{E \cdot k}{F_{yw}}} \quad \text{and} \quad 1.38 \cdot \sqrt{\frac{E \cdot k}{F_{yw}}}$$

And:

$$k = 5.0$$

Modulus of Elasticity:

$$E = 29000 \cdot \text{ksi}$$

Specified minimum yield strength of the web (Design Step 4.1):

$$F_{yw} = F_y$$

$$F_{yw} = 50 \text{ ksi}$$

From Figure 4-1:

Web Depth:

$$D = 54 \text{ in}$$

Thickness of the web:

$$t_w = 0.50 \text{ in}$$

S6.13.6.1.4b

S6.10.7.2

SEquation
6.10.7.1-1

SEquation
6.10.7.2-1

SEquation
6.10.7.2-2

S6.10.7.3.3a

S6.10.7.2

Compare:

$$\frac{D}{t_w} = 108.00$$

to the values for:

$$1.10 \cdot \sqrt{\frac{E \cdot k}{F_{yw}}} = 59.24 \quad \text{and} \quad 1.38 \cdot \sqrt{\frac{E \cdot k}{F_{yw}}} = 74.32$$

Based on the computed value of D/t_w , use the following equation to determine C:

$$C = \frac{1.52}{\left(\frac{D}{t_w}\right)^2} \cdot \left(\frac{E \cdot k}{F_{yw}}\right)$$

$$C = 0.38$$

The nominal shear resistance is computed as follows:

$$V_p = 0.58 \cdot F_{yw} \cdot D \cdot t_w$$

$$V_p = 783.00 \text{ K}$$

$$V_n = C \cdot V_p$$

$$V_n = 295.91 \text{ K}$$

The factored shear resistance now follows:

$$V_r = \phi_v \cdot V_n$$

$$V_r = 295.91 \text{ K}$$

*SEquation
6.10.7.3.3a-7*

At the strength limit state, the design shear, V_{uw} , shall be taken as:

If $V_u < 0.5 V_r$, then:

$$V_{uw} = 1.5 \cdot V_u$$

SEquation
6.13.6.1.4b-1

Otherwise:

$$V_{uw} = \frac{V_u + V_r}{2}$$

SEquation
6.13.6.1.4b-2

The shear due to the Strength I loading at the point of splice, V_u , is computed from the girder shear forces at the splice location listed at the beginning of this design step.

For the Strength I Limit State, the factored shear for the positive live load is:

$$V_{upos} = 0.90 \cdot (V_{NDL} + V_{CDL}) + 1.75 \cdot V_{PLL}$$

$$V_{upos} = -37.17 \text{ K}$$

For the Strength I Limit State, the factored shear for the negative live load is:

$$V_{uneg} = 1.25 \cdot (V_{NDL} + V_{CDL}) + 1.50 \cdot V_{FWS} + 1.75 \cdot V_{NLL}$$

$$V_{uneg} = -262.20 \text{ K} \quad (\text{controls})$$

Therefore:

$$V_u = |V_{uneg}|$$

Since V_u exceeds one-half of V_r :

$$V_{uw} = \frac{V_u + V_r}{2}$$

SEquation
6.13.6.1.4b-2

$$V_{uw} = 279.05 \text{ K}$$

Web Moments and Horizontal Force Resultants:

Case 1 - Dead Load + Positive Live Load:

For the loading condition with positive live load, the controlling flange was previously determined to be the bottom flange. The maximum elastic flexural stress due to the factored loads at the midthickness of the controlling flange, f_{cf} , and the design stress for the controlling flange, F_{cf} , were previously computed for this loading condition. From Table 4-15:

$$f_{cf} = 23.48 \cdot \text{ksi}$$

$$F_{cf} = 37.50 \cdot \text{ksi}$$

For the same loading condition, the concurrent flexural stress at the midthickness of the noncontrolling (top) flange, f_{ncf} , was previously computed. From Table 4-16:

$$f_{ncf} = -0.93 \cdot \text{ksi}$$

Therefore, the portion of the flexural moment assumed to be resisted by the web is computed as:

$$M_w = \frac{t_w \cdot D^2}{12} \cdot |R_h \cdot F_{cf} - R_{cf} \cdot f_{ncf}|$$

CEquation
6.13.6.1.4b-1

where:

The hybrid girder reduction factor: $R_h = 1.00$

The ratio R_{cf} is computed as follows:

$$R_{cf} = \left| \frac{F_{cf}}{f_{cf}} \right| \quad R_{cf} = 1.60$$

Web thickness: $t_w = 0.50 \text{ in}$

Web depth: $D = 54 \text{ in}$

Compute the portion of the flexural moment to be resisted by the web:

$$M_{W_str_pos} = \frac{t_w \cdot D^2}{12} \cdot |R_h \cdot F_{cf} - R_{cf} \cdot f_{ncf}| \cdot \left(\frac{1}{12} \frac{\text{in}}{\text{ft}} \right)$$

$$M_{W_str_pos} = 394.73 \text{ K} \cdot \text{ft}$$

The total web moment is:

$$V_{uw} = 279.05 \text{ K} \quad e = 3.44 \text{ in}$$

$$M_{tot_str_pos} = M_{W_str_pos} + (V_{uw} \cdot e) \cdot \left(\frac{1}{12} \frac{\text{in}}{\text{ft}} \right)$$

$$M_{tot_str_pos} = 474.66 \text{ K} \cdot \text{ft}$$

Compute the horizontal force resultant (the variables included in this equation are as defined for $M_{W_str_pos}$):

$$H_{W_str_pos} = \frac{t_w \cdot D}{2} \cdot (R_h \cdot F_{cf} + R_{cf} \cdot f_{ncf})$$

$$H_{W_str_pos} = 486.20 \text{ K}$$

The above value is a signed quantity, positive for tension and negative for compression.

*CEquation
6.13.6.1.4b-2*

Case 2 - Dead Load + Negative Live Load:

Similarly, for the loading condition with negative live load, the controlling flange was determined to be the bottom flange. For this case the stresses were previously computed. From Table 4-15:

$$f_{cf} = -19.54 \cdot \text{ksi}$$

$$F_{cf} = -37.50 \cdot \text{ksi}$$

For the noncontrolling (top) flange, the flexural stress at the midthickness of the flange, from Table 4-16:

$$f_{ncf} = 14.13 \cdot \text{ksi}$$

The ratio, R_{cf} , is computed as follows:

$$R_{cf} = \left| \frac{F_{cf}}{f_{cf}} \right| \quad R_{cf} = 1.92$$

Therefore:

$$M_{w_str_neg} = \frac{t_w \cdot D^2}{12} \cdot |R_h \cdot F_{cf} - R_{cf} \cdot f_{ncf}| \cdot \left(\frac{1}{12} \frac{\text{in}}{\text{ft}} \right)$$

$$M_{w_str_neg} = 654.25 \text{ K} \cdot \text{ft}$$

The total web moment is:

$$V_{uw} = 279.05 \text{ K} \quad e = 3.44 \text{ in}$$

$$M_{\text{tot_str_neg}} = M_{w_str_neg} + (V_{uw} \cdot e) \cdot \left(\frac{1}{12} \frac{\text{in}}{\text{ft}} \right)$$

$$M_{\text{tot_str_neg}} = 734.19 \text{ K} \cdot \text{ft}$$

Compute the horizontal force resultant:

$$H_{w_str_neg} = \frac{t_w \cdot D}{2} \cdot (R_h \cdot F_{cf} + R_{cf} \cdot f_{ncf})$$

$$H_{w_str_neg} = -140.16 \text{ K}$$

The above value is a signed quantity, positive for tension, and negative for compression.

Service II Limit State:*Design Shear:*

As a minimum, for checking slip of the web splice bolts, the design shear shall be taken as the shear at the point of splice under the Service II Limit State, or the shear from constructibility, whichever governs. In this design example, the Service II shear controls (see previous discussion in Design Step 4.3).

S6.13.6.1.4b

The elastic shears due to the unfactored loads at the point of the splice are listed at the beginning of this design step.

For the Service II Limit State, the factored shear for the positive live load is (ignore future wearing surface):

$$V_{\text{ser_pos}} = 1.00 \cdot V_{\text{NDL}} + 1.00 \cdot V_{\text{CDL}} + 1.30 \cdot V_{\text{PLL}}$$

$$V_{\text{ser_pos}} = -50.65 \text{ K}$$

For the Service II Limit State, the factored shear for the negative live load is (include future wearing surface):

$$V_{\text{ser_neg}} = 1.00 \cdot V_{\text{NDL}} + 1.00 \cdot V_{\text{CDL}} + 1.00 \cdot V_{\text{FWS}} + 1.30 \cdot V_{\text{NLL}}$$

$$V_{\text{ser_neg}} = -198.53 \text{ K} \quad (\text{governs})$$

Therefore:

$$V_{\text{w_ser}} = |V_{\text{ser_neg}}|$$

Web Moments and Horizontal Force Resultants:

The web design moment and horizontal force resultant are computed using *CEquation 6.13.6.1.4b-1* and *CEquation 6.13.6.1.4b-2*, modified for the Service II Limit State as follows:

C6.13.6.1.4b

$$M_{w_ser} = \frac{t_w \cdot D^2}{12} \cdot |f_s - f_{os}|$$

$$H_{w_ser} = \frac{t_w \cdot D}{2} \cdot (f_s + f_{os})$$

In the above equations, f_s is the maximum Service II midthickness flange stress for the load case considered (i.e., positive or negative live load). The Service II midthickness flange stress in the other flange, concurrent with f_s , is termed f_{os} .

Case 1 - Dead Load + Positive Live Load:

The maximum midthickness flange flexural stress for the load case with positive live load moment for the Service II Limit State occurs in the bottom flange. From Table 4-13:

$$f_{s_bot_pos} = 15.10 \cdot \text{ksi}$$

$$f_{os_top_pos} = -0.65 \cdot \text{ksi}$$

Therefore, for the load case of positive live load:

$$M_{w_ser_pos} = \frac{t_w \cdot D^2}{12} \cdot |f_{s_bot_pos} - f_{os_top_pos}| \cdot \left(\frac{1}{12} \frac{\text{in}}{\text{ft}} \right)$$

$$M_{w_ser_pos} = 159.47 \text{ K}\cdot\text{ft}$$

The total web moment is:

$$V_{w_ser} = 198.53 \text{ K} \quad e = 3.44 \text{ in}$$

$$M_{tot_ser_pos} = M_{w_ser_pos} + (V_{w_ser} \cdot e) \cdot \left(\frac{1}{12 \cdot \frac{\text{in}}{\text{ft}}} \right)$$

$$M_{tot_ser_pos} = 216.34 \text{ K} \cdot \text{ft}$$

Compute the horizontal force resultant:

$$H_{w_ser_pos} = \frac{t_w \cdot D}{2} \cdot (f_{s_bot_pos} + f_{os_top_pos})$$

$$H_{w_ser_pos} = 195.08 \text{ K}$$

The above value is a signed quantity, positive for tension, and negative for compression.

Case 2 - Dead Load + Negative Live Load:

The maximum midthickness flange flexural stress for the load case with negative live load moment for the Service II Limit State occurs in the bottom flange. From Table 4-13:

$$f_{s_bot_neg} = -11.85 \cdot \text{ksi}$$

$$f_{os_top_neg} = 1.80 \cdot \text{ksi}$$

Therefore:

$$M_{W_ser_neg} = \frac{t_w \cdot D^2}{12} \cdot |f_{s_bot_neg} - f_{os_top_neg}| \cdot \left(\frac{1}{12 \cdot \frac{\text{in}}{\text{ft}}} \right)$$

$$M_{W_ser_neg} = 138.21 \text{ K} \cdot \text{ft}$$

The total web moment is:

$$V_{W_ser} = 198.53 \text{ K} \qquad e = 3.44 \text{ in}$$

$$M_{tot_ser_neg} = M_{W_ser_neg} + (V_{W_ser} \cdot e) \cdot \left(\frac{1}{12 \cdot \frac{\text{in}}{\text{ft}}} \right)$$

$$M_{tot_ser_neg} = 195.08 \text{ K} \cdot \text{ft}$$

Compute the horizontal force resultant:

$$H_{W_ser_neg} = \frac{t_w \cdot D}{2} \cdot (f_{s_bot_neg} + f_{os_top_neg})$$

$$H_{W_ser_neg} = -135.68 \text{ K}$$

The above value is a signed quantity, positive for tension, and negative for compression.

Fatigue Limit State:

Fatigue of the base metal adjacent to the slip-critical connections in the splice plates may be checked as specified in *S*Table 6.6.1.2.3-1 using the gross section of the splice plates and member. However, the areas of the web splice plates will often equal or exceed the area of the web to which it is attached (the case in this design example). Therefore, fatigue will generally not govern the design of the splice plates, but is carried out in this example for completeness.

C6.13.6.1.4a

Design Shear:

For the Fatigue Limit State, the factored shear for the positive live load is:

$$V_{fat_pos} = 0.75 \cdot V_{PFLL}$$

$$V_{fat_pos} = 3.75 K$$

For the Fatigue Limit State, the factored shear for the negative live load is:

$$V_{fat_neg} = 0.75 \cdot V_{NFLL}$$

$$V_{fat_neg} = -25.05 K$$

Web Moments and Horizontal Force Resultants:

The portion of the flexural moment to be resisted by the web and the horizontal force resultant are computed from equations similar to *C*Equations 6.13.6.1.4b-1 and 6.13.6.1.4b-2, respectively, with appropriate substitutions of the stresses in the web caused by the fatigue-load moment for the flange stresses in the equations. Also, the absolute value signs are removed to keep track of the signs. This yields the following equations:

$$M_w = \frac{t_w \cdot D^2}{12} \cdot (f_{botweb} - f_{topweb})$$

$$H_w = \frac{t_w \cdot D}{2} \cdot (f_{botweb} + f_{topweb})$$

Case 1 - Positive Live Load:

The factored stresses due to the positive live load moment for the Fatigue Limit State at the top and bottom of the web, from Table 4-14, are:

$$f_{\text{topweb_pos}} = -0.22 \cdot \text{ksi}$$

$$f_{\text{botweb_pos}} = 2.67 \cdot \text{ksi}$$

Therefore:

$$M_{w_fat_pos} = \frac{t_w \cdot D^2}{12} \cdot (f_{\text{botweb_pos}} - f_{\text{topweb_pos}}) \cdot \left(\frac{1}{12} \frac{\text{in}}{\text{ft}} \right)$$

$$M_{w_fat_pos} = 29.26 \text{ K} \cdot \text{ft}$$

The total web moment is:

$$V_{\text{fat_pos}} = 3.75 \text{ K} \quad e = 3.44 \text{ in}$$

$$M_{\text{tot_fat_pos}} = M_{w_fat_pos} + (V_{\text{fat_pos}} \cdot e) \cdot \left(\frac{1}{12} \frac{\text{in}}{\text{ft}} \right)$$

$$M_{\text{tot_fat_pos}} = 30.34 \text{ K} \cdot \text{ft}$$

Compute the horizontal force resultant:

$$H_{w_fat_pos} = \frac{t_w \cdot D}{2} \cdot (f_{\text{botweb_pos}} + f_{\text{topweb_pos}})$$

$$H_{w_fat_pos} = 33.08 \text{ K}$$

The above value is a signed quantity, positive for tension, and negative for compression.

Case 2 - Negative Live Load:

The factored stresses due to the negative live load moment for the Fatigue Limit State at the top and bottom of the web, from Table 4-14, are:

$$f_{\text{botweb_neg}} = -1.92 \cdot \text{ksi}$$

$$f_{\text{topweb_neg}} = 0.16 \cdot \text{ksi}$$

Therefore:

$$M_{\text{w_fat_neg}} = \frac{t_w \cdot D^2}{12} \cdot (f_{\text{botweb_neg}} - f_{\text{topweb_neg}}) \cdot \left(\frac{1}{12 \frac{\text{in}}{\text{ft}}} \right)$$

$$M_{\text{w_fat_neg}} = -21.06 \text{ K} \cdot \text{ft}$$

The total web moment is:

$$V_{\text{fat_neg}} = -25.05 \text{ K} \quad e = 3.44 \text{ in}$$

$$M_{\text{tot_fat_neg}} = M_{\text{w_fat_neg}} + (V_{\text{fat_neg}} \cdot e) \cdot \left(\frac{1}{12 \cdot \frac{\text{in}}{\text{ft}}} \right)$$

$$M_{\text{tot_fat_neg}} = -28.24 \text{ K} \cdot \text{ft}$$

Compute the horizontal force resultant:

$$H_{\text{w_fat_neg}} = \frac{t_w \cdot D}{2} \cdot (f_{\text{botweb_neg}} + f_{\text{topweb_neg}})$$

$$H_{\text{w_fat_neg}} = -23.76 \text{ K}$$

The above value is a signed quantity, positive for tension, and negative for compression.

Design Step 4.7 - Design Web Splice**Web Splice Configuration:**

Two vertical rows of bolts with sixteen bolts per row will be investigated. The typical bolt spacings, both horizontally and vertically, are as shown in Figure 4-8. The outermost rows of bolts are located 4 1/2" from the flanges to provide clearance for assembly (see the *AISC Manual of Steel Construction* for required bolt assembly clearances). The web is spliced symmetrically by plates on each side with a thickness not less than one-half the thickness of the web. Assume 5/16" x 48" splice plates on each side of the web. No web fill plate is necessary for this example.

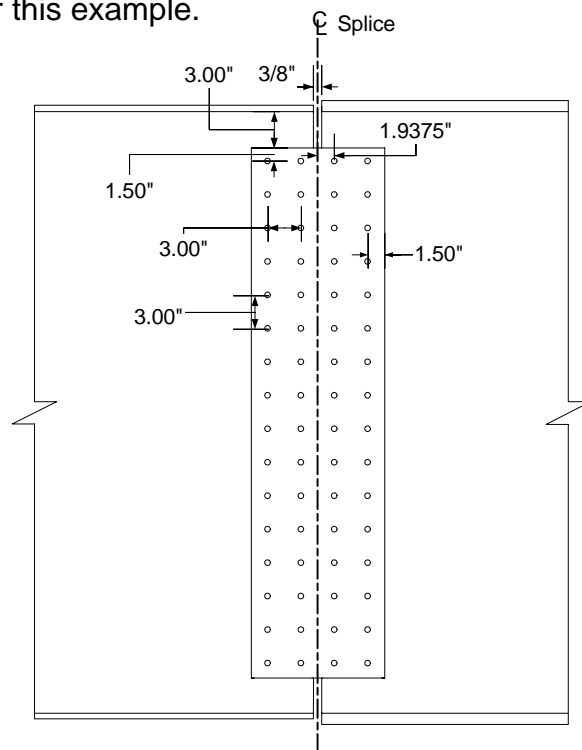
**Figure 4-8 Web Splice****Web Splice Design**

It is recommended to extend the web splice plates as near as practical to the full depth of the web between flanges without impinging on bolt assembly clearances. Also, two vertical rows of bolts in the web on each side of the splice is considered a standard minimum. This may result in an oversized web splice, but is considered good engineering practice.

Web Bolts - Minimum Spacing:

S6.13.2.6.1

This check is only dependent upon the bolt diameter, and is therefore satisfied for a three inch spacing per the check for the flange bolts from Design Step 4.4.

Web Bolts - Maximum Spacing for Sealing:

S6.13.2.6.2

The maximum spacing of the bolts is limited to prevent penetration of moisture in the joints.

For a single line adjacent to a free edge of an outside plate or shape (for example, the bolts along the edges of the plate parallel to the direction of the applied force):

$$s \leq (4.0 + 4.0 \cdot t) \leq 7.0$$

where:

Thickness of the thinner outside plate or shape, in this case the web plate: $t_{wp} = 0.3125 \cdot \text{in}$

Maximum spacing for sealing:

$$4.0 \cdot \text{in} + 4.0 \cdot t_{wp} = 5.25 \text{ in} \qquad 5.25 \cdot \text{in} \leq 7.00 \cdot \text{in}$$

$$3.0 \cdot \text{in} \leq 5.25 \cdot \text{in} \quad \text{OK}$$

Web Bolts - Maximum Pitch for Stitch Bolts:

S6.13.2.6.3

The maximum pitch requirements are applicable only for mechanically fastened built-up members and will not be applied in this example.

Web Bolts - Edge Distance:

S6.13.2.6.6

Minimum:

The minimum required edge distance is measured as the distance from the center of any bolt in a standard hole to an edge of the plate.

For a 7/8" diameter bolt measured to a sheared edge, the minimum edge distance is 1 1/2".

STable 6.13.2.6.6-1

Referring to Figure 4-8, it is clear that the minimum edge distance specified for this example is 1 1/2" and thus satisfies the minimum requirement.

Maximum:

The maximum edge distance shall not be more than eight times the thickness of the thinnest outside plate or five inches.

$$8 \cdot t \leq 5.00 \cdot \text{in}$$

where:

$$t = t_{wp}$$

$$t_{wp} = 0.3125 \text{ in}$$

The maximum edge distance allowable is:

$$8 \cdot t_{wp} = 2.50 \text{ in}$$

The maximum distance from the corner bolts to the corner of the splice plate or girder flange is equal to (reference Figure 4-8):

$$\sqrt{(1.50 \cdot \text{in})^2 + (1.50 \cdot \text{in})^2} = 2.12 \text{ in}$$

and satisfies the maximum edge distance requirement.

$$2.12 \cdot \text{in} \leq 2.50 \cdot \text{in} \quad \text{OK}$$

Web Bolts - Shear:

Calculate the polar moment of inertia, I_p , of the bolt group on each side of the centerline with respect to the centroid of the connection. This is required for determination of the shear force in a given bolt due to the applied web moments.

$$I_p = \frac{n \cdot m}{12} [s^2 \cdot (n^2 - 1) + g^2 \cdot (m^2 - 1)]$$

CEquation
6.13.6.1.4b-3

where:

Number of vertical rows of bolts:	$m = 2$
Number of bolts in one vertical row:	$n = 16$
Vertical pitch:	$s = 3.00 \cdot \text{in}$
Horizontal pitch:	$g = 3.00 \cdot \text{in}$

The polar moment of inertia is:

$$I_p = \frac{n \cdot m}{12} [s^2 \cdot (n^2 - 1) + g^2 \cdot (m^2 - 1)]$$

$$I_p = 6192.00 \text{ in}^2$$

The total number of web bolts on each side of the splice, assuming two vertical rows per side with sixteen bolts per row, is:

$$N_b = 32$$

Strength I Limit State:

Under the most critical combination of the minimum design shear, moment and horizontal force, it is assumed that the bolts in the web splice have slipped and gone into bearing. The shear strength of an ASTM A325 7/8" diameter high-strength bolt in double shear, assuming the threads are excluded from the shear planes, was computed in Design Step 4.4 for Flange Bolts - Shear:

$$R_u = 55.42 \text{ K}$$



Threads in the Shear Plane

Since the bolt shear strength for both the flange and web splices is based on the assumption that the threads are excluded from the shear planes, an appropriate note should be placed on the drawings to ensure that the splice is detailed to exclude the bolt threads from the shear planes.

Case 1 - Dead Load + Positive Live Load:

The following forces were computed in Design Step 4.6:

$$V_{uw} = 279.05 \text{ K}$$

$$M_{\text{tot_str_pos}} = 474.66 \text{ K}\cdot\text{ft}$$

$$H_{w_str_pos} = 486.20 \text{ K}$$

The vertical shear force in the bolts due to the applied shear force:

$$P_{v_str} = \frac{V_{uw}}{N_b}$$

$$P_{v_str} = 8.72 \text{ K}$$

The horizontal shear force in the bolts due to the horizontal force resultant:

$$P_{H_str_pos} = \frac{H_{w_str_pos}}{N_b}$$

$$P_{H_str_pos} = 15.19 \text{ K}$$

Determine the horizontal and vertical components of the bolt shear force on the extreme bolt due to the total moment in the web:

$$P_{Mv} = \frac{M_{\text{total}} \cdot x}{I_p} \quad \text{and} \quad P_{Mh} = \frac{M_{\text{total}} \cdot y}{I_p}$$

For the vertical component:

$$x = \frac{g}{2} \quad x = 1.50 \text{ in}$$

For the horizontal component:

$$y = \frac{15 \cdot s}{2} \quad y = 22.50 \text{ in}$$

Calculating the components:

$$P_{Mv_str_pos} = \frac{M_{tot_str_pos} \cdot (x)}{I_p} \cdot \left(12 \cdot \frac{\text{in}}{\text{ft}}\right)$$

$$P_{Mv_str_pos} = 1.38 \text{ K}$$

$$P_{Mh_str_pos} = \frac{M_{tot_str_pos}(y)}{I_p} \cdot \left(12 \cdot \frac{\text{in}}{\text{ft}}\right)$$

$$P_{Mh_str_pos} = 20.70 \text{ K}$$

The resultant bolt force for the extreme bolt is:

$$P_{r_str_pos} = \sqrt{(P_{V_str} + P_{Mv_str_pos})^2 + (P_{H_str_pos} + P_{Mh_str_pos})^2}$$

$$P_{r_str_pos} = 37.29 \text{ K}$$

Case 2 - Dead Load + Negative Live Load:

The following forces were computed in Design Step 4.6:

$$V_{uw} = 279.05 \text{ K}$$

$$M_{\text{tot_str_neg}} = 734.19 \text{ K}\cdot\text{ft}$$

$$H_{w_str_neg} = -140.16 \text{ K}$$

The vertical shear force in the bolts due to the applied shear force:

$$P_{v_str} = \frac{V_{uw}}{N_b}$$

$$P_{v_str} = 8.72 \text{ K}$$

The horizontal shear force in the bolts due to the horizontal force resultant:

$$P_{H_str_neg} = \frac{|H_{w_str_neg}|}{N_b}$$

$$P_{H_str_neg} = 4.38 \text{ K}$$

Determine the horizontal and vertical components of the bolt shear force on the extreme bolt due to the total moment in the web:

Calculating the components:

$$P_{Mv_str_neg} = \frac{M_{\text{tot_str_neg}} \cdot (x)}{I_p} \cdot \left(12 \cdot \frac{\text{in}}{\text{ft}} \right)$$

$$P_{Mv_str_neg} = 2.13 \text{ K}$$

$$P_{Mh_str_neg} = \frac{M_{tot_str_neg}(y)}{I_p} \cdot \left(12 \cdot \frac{\text{in}}{\text{ft}}\right)$$

$$P_{Mh_str_neg} = 32.01 \text{ K}$$

The resultant bolt force is:

$$P_{r_str_neg} = \sqrt{(P_{V_str} + P_{Mv_str_neg})^2 + (P_{H_str_neg} + P_{Mh_str_neg})^2}$$

$$P_{r_str_neg} = 37.98 \text{ K}$$

The governing resultant bolt force is:

$$P_{r_str} = \max(P_{r_str_pos}, P_{r_str_neg})$$

$$P_{r_str} = 37.98 \text{ K}$$

Check:

$$P_{r_str} = 37.98 \text{ K} < R_u = 55.42 \text{ K} \quad \text{OK}$$

Service II Limit State:

The factored slip resistance, R_r , for a 7/8" diameter high-strength bolt in double shear for a Class B surface and standard holes was determined from Design Step 4.4 to be:

$$R_r = 39.00 \cdot K$$

Case 1 - Dead Load + Positive Live Load:

The following forces were computed in Design Step 4.6:

$$V_{w_ser} = 198.53 K$$

$$M_{tot_ser_pos} = 216.34 K \cdot ft$$

$$H_{w_ser_pos} = 195.08 K$$

The vertical shear force in the bolts due to the applied shear force:

$$P_{s_ser} = \frac{V_{w_ser}}{N_b}$$

$$P_{s_ser} = 6.20 K$$

The horizontal shear force in the bolts due to the horizontal force resultant:

$$P_{H_ser_pos} = \frac{H_{w_ser_pos}}{N_b}$$

$$P_{H_ser_pos} = 6.10 K$$

Determine the horizontal and vertical components of the bolt shear force on the extreme bolt due to the total moment in the web:

For the vertical component:

$$x = 1.50 \text{ in}$$

$$P_{Mv_ser_pos} = \frac{M_{tot_ser_pos} \cdot (x)}{I_p} \cdot \left(12 \cdot \frac{\text{in}}{\text{ft}}\right)$$

$$P_{Mv_ser_pos} = 0.63 \text{ K}$$

For the horizontal component:

$$y = 22.50 \text{ in}$$

$$P_{Mh_ser_pos} = \frac{M_{tot_ser_pos}(y)}{I_p} \cdot \left(12 \cdot \frac{\text{in}}{\text{ft}}\right)$$

$$P_{Mh_ser_pos} = 9.43 \text{ K}$$

The resultant bolt force is:

$$P_{r_ser_pos} = \sqrt{(P_{s_ser} + P_{Mv_ser_pos})^2 + (P_{H_ser_pos} + P_{Mh_ser_pos})^2}$$

$$P_{r_ser_pos} = 16.97 \text{ K}$$

Case 2 - Dead Load + Negative Live Load:

The following forces were computed in Design Step 4.6:

$$V_{w_ser} = 198.53 \text{ K}$$

$$M_{tot_ser_neg} = 195.08 \text{ K}\cdot\text{ft}$$

$$H_{w_ser_neg} = -135.68 \text{ K}$$

The vertical shear force in the bolts due to the applied shear force:

$$P_{s_ser} = \frac{V_{w_ser}}{N_b}$$

$$P_{s_ser} = 6.20 \text{ K}$$

The horizontal shear force in the bolts due to the horizontal force resultant:

$$P_{H_ser_neg} = \frac{|H_{w_ser_neg}|}{N_b}$$

$$P_{H_ser_neg} = 4.24 \text{ K}$$

Determine the horizontal and vertical components of the bolt shear force on the extreme bolt due to the total moment in the web:

For the vertical component:

$$P_{Mv_ser_neg} = \frac{M_{tot_ser_neg} \cdot (x)}{I_p} \cdot \left(12 \cdot \frac{\text{in}}{\text{ft}}\right)$$

$$P_{Mv_ser_neg} = 0.57 \text{ K}$$

For the horizontal component:

$$P_{Mh_ser_neg} = \frac{M_{tot_ser_neg}(y)}{I_p} \cdot \left(12 \cdot \frac{\text{in}}{\text{ft}}\right)$$

$$P_{Mh_ser_neg} = 8.51 \text{ K}$$

The resultant bolt force is:

$$P_{r_ser_neg} = \sqrt{(P_{s_ser} + P_{Mv_ser_neg})^2 + (P_{H_ser_neg} + P_{Mh_ser_neg})^2}$$

$$P_{r_ser_neg} = 14.43 \text{ K}$$

The governing resultant bolt force is:

$$P_{r_ser} = \max(P_{r_ser_pos}, P_{r_ser_neg})$$

$$P_{r_ser} = 16.97 \text{ K}$$

Check:

$$P_{r_ser} = 16.97 \text{ K} < R_r = 39.00 \text{ K} \quad \text{OK}$$

Thirty-two 7/8" diameter high-strength bolts in two vertical rows on each side of the splice provides sufficient resistance against bolt shear and slip.

Shear Yielding of Splice Plates:

S6.13.6.1.4b

Check for shear yielding on the gross section of the web splice plates under the Strength I design shear force, V_{UW} :

$$V_{UW} = 279.05 \text{ K}$$

The factored resistance of the splice plates is taken as:

$$R_r = \phi_V \cdot R_n$$

SEquation
6.13.5.3-1

$$R_n = 0.58 \cdot A_g \cdot F_y$$

SEquation
6.13.5.3-2

The gross area of the web splice is calculated as follows:

Number of splice plates: $N_{wp} = 2$

Thickness of plate: $t_{wp} = 0.3125 \cdot \text{in}$

Depth of splice plate: $d_{wp} = 48 \cdot \text{in}$

$$A_{\text{gross_wp}} = N_{wp} \cdot t_{wp} \cdot d_{wp}$$

$$A_{\text{gross_wp}} = 30.00 \text{ in}^2$$

From Design Step 4.1:

Specified minimum yield strength of the connection element: $F_y = 50 \text{ ksi}$

Resistance factor for shear: $\phi_V = 1.0$

The factored shear resistance is then:

$$R_r = \phi_V \cdot (0.58) \cdot (A_{\text{gross_wp}}) \cdot (F_y)$$

$$R_r = 870.00 \text{ K}$$

Check:

$$V_{UW} = 279.05 \text{ K} < R_r = 870.00 \text{ K} \text{ OK}$$

Fracture and Block Shear Rupture of the Web Splice Plates:

S6.13.6.1.4b

Strength I Limit State checks for fracture on the net section of web splice plates and block shear rupture normally do not govern for plates of typical proportion. These checks are provided in this example for completeness.

From Design Step 4.6, the factored design shear for the Strength I Limit State was determined to be:

$$V_{UW} = 279.05K$$

Fracture on the Net Section:

C6.13.4

Investigation of critical sections and failure modes, other than block shear, is recommended, including the case of a net section extending across the full plate width, and, therefore, having no parallel planes. This may be a more severe requirement for a girder flange or splice plate than the block shear rupture mode.

For this case, the areas of the plate resisting tension are considered to be zero.

$$A_{tg} = 0.0 \cdot \text{in}^2$$

$$A_{tn} = 0.0 \cdot \text{in}^2$$

Therefore, the factored resistance is:

$$R_r = \phi_{bs} \cdot (0.58 \cdot F_u \cdot A_{vn} + F_y \cdot A_{tg})$$

SEquation 6.13.4-2

$$\phi_{bs} = 0.80$$

(Design Step 4.1)

where the net area resisting shear:

$$A_{vn} = N_{wp} \cdot (d_{wp} - N_{fn} \cdot d_{hole}) \cdot t_{wp}$$

Number of web plates:	$N_{wp} = 2$
Depth of the web plate:	$d_{wp} = 48 \text{ in}$
Number of bolts along one plane:	$N_{fn} = 16$
Thickness of the web plate:	$t_{wp} = 0.3125 \text{ in}$
From Design Step 4.1:	
Specified minimum yield strength of the connected material:	$F_y = 50 \text{ ksi}$
Specified minimum tensile strength of the connected material:	$F_u = 65 \text{ ksi}$
Diameter of the bolt holes:	$d_{hole} = 1.0 \text{ in}$

Net area resisting shear:

$$A_{vn} = N_{wp} \cdot (d_{wp} - N_{fn} \cdot d_{hole}) \cdot t_{wp}$$

$$A_{vn} = 20.00 \text{ in}^2$$

A_{vn} of the splice plates to be used in calculating the fracture strength of the splice plates cannot exceed eighty-five percent of the gross area of the plates:

$$A_{85} = 0.85 \cdot A_{gross_wp}$$

$$A_{gross_wp} = 30.00 \text{ in}^2$$

$$A_{85} = 25.50 \text{ in}^2 > A_{vn} = 20.00 \text{ in}^2 \quad \text{OK}$$

The factored resistance is then:

$$R_r = \phi_{bs} \cdot (0.58 \cdot F_u \cdot A_{vn})$$

$$R_r = 603.20 \text{ K} > V_{uw} = 279.05 \text{ K} \quad \text{OK}$$

S6.13.5.2

Block Shear Rupture Resistance:

S6.13.4

Connection plates, splice plates and gusset plates shall be investigated to ensure that adequate connection material is provided to develop the factored resistance of the connection.

Determine the applicable equation:

If $A_{tn} \geq 0.58 \cdot A_{vn}$ then:

$$R_r = \phi_{bs} \cdot (0.58 \cdot F_y \cdot A_{vg} + F_u \cdot A_{tn})$$

SEquation
6.13.4-1

otherwise:

$$R_r = \phi_{bs} \cdot (0.58 \cdot F_u \cdot A_{vn} + F_y \cdot A_{tg})$$

SEquation
6.13.4-2

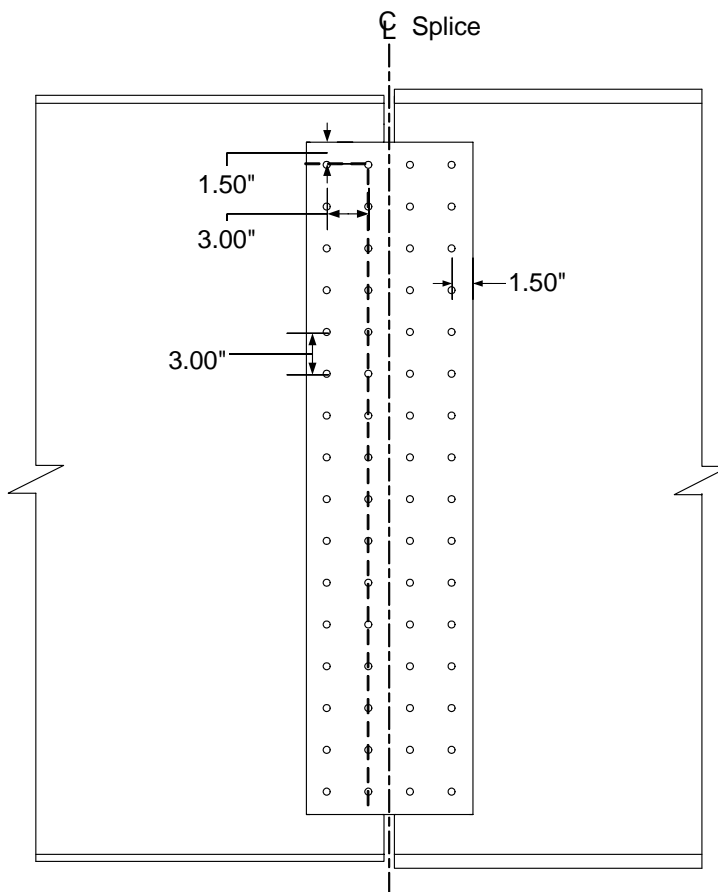

Figure 4-9 Block Shear Failure Mode - Web Splice Plate

Gross area along the plane resisting shear stress:

$$A_{vg} = N_{wp} \cdot (d_{wp} - 1.50 \cdot \text{in}) \cdot t_{wp}$$

$$A_{vg} = 29.06 \text{ in}^2$$

Net area along the plane resisting shear stress:

$$A_{vn} = N_{wp} \cdot [d_{wp} - 1.50 \cdot \text{in} - 15.50 \cdot (d_{\text{hole}})] \cdot t_{wp}$$

$$A_{vn} = 19.38 \text{ in}^2$$

Gross area along the plane resisting tension stress:

$$A_{tg} = N_{wp} \cdot (1.50 \cdot \text{in} + 3.0 \cdot \text{in}) \cdot t_{wp}$$

$$A_{tg} = 2.81 \text{ in}^2$$

Net area along the plane resisting tension stress:

$$A_{tn} = N_{wp} \cdot [1.50 \cdot \text{in} + 3.0 \cdot \text{in} - 1.5 \cdot (d_{\text{hole}})] \cdot t_{wp}$$

$$A_{tn} = 1.88 \text{ in}^2$$

Identify the appropriate block shear equation:

$$A_{tn} = 1.88 \text{ in}^2 < 0.58 \cdot A_{vn} = 11.24 \text{ in}^2$$

Therefore, *SEquation 6.13.4-2* is the governing equation:

$$R_r = \phi_{bs} \cdot (0.58 \cdot F_u \cdot A_{vn} + F_y \cdot A_{tg})$$

$$R_r = 696.85 \text{ K}$$

Check:

$$V_{uw} = 279.05 \text{ K} < R_r = 696.85 \text{ K} \quad \text{OK}$$

Flexural Yielding of Splice Plates:

S6.13.6.1.4b

Check for flexural yielding on the gross section of the web splice plates for the Strength I Limit State due to the total web moment and the horizontal force resultant:

$$f = \frac{M_{\text{Total}}}{S_{\text{pl}}} + \frac{H_{\text{uw}}}{A_{\text{gross_wp}}} \leq \phi_f \cdot F_y$$

where:

Resistance factor for flexure (Design Step 4.1): $\phi_f = 1.0$

Section modulus of the web splice plate:

$$S_{\text{pl}} = \frac{1}{6} \cdot A_{\text{gross_wp}} \cdot d_{\text{wp}}$$

$$S_{\text{pl}} = 240.00 \text{ in}^3$$

Case 1 - Dead Load + Positive Live Load:

$$M_{\text{tot_str_pos}} = 474.66 \text{ K}\cdot\text{ft}$$

$$H_{\text{w_str_pos}} = 486.20 \text{ K}$$

$$f_{\text{str_pos}} = \frac{M_{\text{tot_str_pos}}}{S_{\text{pl}}} \cdot \left(12 \cdot \frac{\text{in}}{\text{ft}}\right) + \frac{H_{\text{w_str_pos}}}{A_{\text{gross_wp}}}$$

$$f_{\text{str_pos}} = 39.94 \text{ ksi}$$

$$f_{\text{str_pos}} = 39.94 \text{ ksi} < \phi_f \cdot F_y = 50 \text{ ksi} \quad \text{OK}$$

Case 2 - Dead Load + Negative Live Load:

$$M_{\text{tot_str_neg}} = 734.19 \text{ K}\cdot\text{ft}$$

$$H_{\text{w_str_neg}} = -140.16 \text{ K}$$

$$f_{\text{str_neg}} = \frac{M_{\text{tot_str_neg}}}{S_{\text{pl}}} \cdot \left(12 \cdot \frac{\text{in}}{\text{ft}}\right) + \frac{|H_{\text{w_str_neg}}|}{A_{\text{gross_wp}}}$$

$$f_{\text{str_neg}} = 41.38 \text{ ksi}$$

$$f_{\text{str_neg}} = 41.38 \text{ ksi} < \phi_f \cdot F_y = 50 \text{ ksi} \quad \text{OK}$$

Control of Permanent Deflection - Splice Plates:

S6.10.5.2

Check the maximum normal stress on the gross section of the web splice plates for the Service II Limit State due to the total web moment and horizontal force resultant:

$$f = \frac{M_{\text{Total}}}{S_{\text{pl}}} + \frac{H_w}{A_{\text{gross_wp}}} \leq 0.95 \cdot F_y$$

where:

$$S_{\text{pl}} = 240.00 \text{ in}^3$$

$$A_{\text{gross_wp}} = 30.00 \text{ in}^2$$

Case 1 - Dead Load + Positive Live Load:

$$M_{\text{tot_ser_pos}} = 216.34 \text{ K}\cdot\text{ft}$$

$$H_{w_ser_pos} = 195.08 \text{ K}$$

$$f_{\text{ser_pos}} = \frac{M_{\text{tot_ser_pos}}}{S_{\text{pl}}} \cdot \left(12 \cdot \frac{\text{in}}{\text{ft}} \right) + \frac{H_{w_ser_pos}}{A_{\text{gross_wp}}}$$

$$f_{\text{ser_pos}} = 17.32 \text{ ksi}$$

$$f_{\text{ser_pos}} = 17.32 \text{ ksi} < 0.95 \cdot F_y = 47.50 \text{ ksi} \quad \text{OK}$$

Case 2 - Dead Load + Negative Live Load:

$$M_{\text{tot_ser_neg}} = 195.08 \text{ K}\cdot\text{ft}$$

$$H_{\text{w_ser_neg}} = -135.68 \text{ K}$$

$$f_{\text{ser_neg}} = \frac{M_{\text{tot_ser_neg}}}{S_{\text{pl}}} \cdot \left(12 \cdot \frac{\text{in}}{\text{ft}}\right) + \frac{|H_{\text{w_ser_neg}}|}{A_{\text{gross_wp}}}$$

$$f_{\text{ser_neg}} = 14.28 \text{ ksi}$$

$$f_{\text{ser_neg}} = 14.28 \text{ ksi} < 0.95 \cdot F_y = 47.50 \text{ ksi} \quad \text{OK}$$

Web Bolts - Bearing Resistance at Bolt Holes:

S6.13.2.9

Since the girder web thickness is less than twice the thickness of the web splice plates, the girder web will control for the bearing check.

Check the bearing of the bolts on the connected material for the Strength I Limit State assuming the bolts have slipped and gone into bearing. The design bearing strength of the girder web at the location of the extreme bolt in the splice is computed as the minimum resistance along the two orthogonal shear failure planes shown in Figure 4-10. The maximum force (vector resultant) acting on the extreme bolt is compared to this calculated strength, which is conservative since the components of this force parallel to the failure surfaces are smaller than the maximum force.

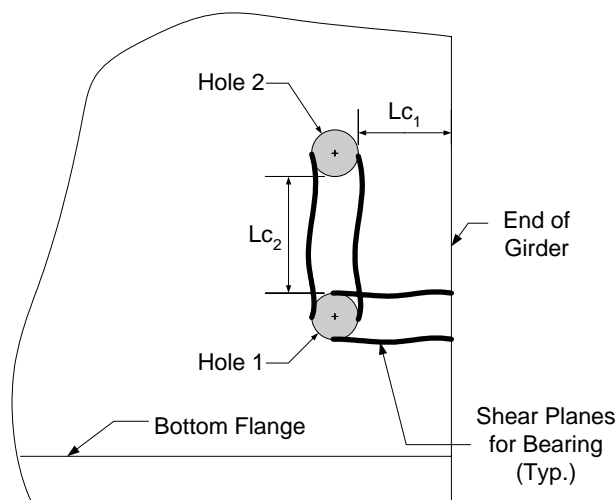

Figure 4-10 Bearing Resistance - Girder Web

To determine the applicable equation for the calculation of the nominal bearing resistance, the clear distance between holes and the clear end distance must be calculated and compared to the value of two times the nominal diameter of the bolt. This check yields:

S6.13.2.9

$$d_{\text{bolt}} = 0.875 \text{ in} \quad (\text{Design Step 4.1})$$

$$2 \cdot d_{\text{bolt}} = 1.75 \text{ in}$$

The edge distance from the center of the hole to the edge of the girder is taken as 1.75". Therefore, the clear distance between the edge of the hole and the edge of the girder is computed as follows:

$$L_{c_1} = 1.75 \cdot \text{in} - \frac{d_{\text{hole}}}{2}$$

$$d_{\text{hole}} = 1.0 \text{ in} \quad (\text{Design Step 4.1})$$

$$L_{c_1} = 1.25 \text{ in}$$

The center-to-center distance between adjacent holes is 3". Therefore, the clear distance between holes is:

$$L_{c_2} = 3.00 \cdot \text{in} - d_{\text{hole}}$$

$$L_{c_2} = 2.00 \text{ in}$$

For standard holes, where either the clear distance between holes is less than $2.0d$, or the clear end distance is less than $2.0d$:

$$R_n = 1.2 \cdot L_c \cdot t \cdot F_u$$

From Design Step 4.1:

Thickness of the connected material: $t_w = 0.50 \text{ in}$

Tensile strength of the connected material: $F_u = 65 \text{ ksi}$

The nominal bearing resistance at the extreme bolt hole is as follows:

$$R_n = 1.2 \cdot L_{c_1} \cdot t_w \cdot F_u$$

$$R_n = 48.75 \text{ K}$$

S6.13.2.6.6

SEquation
6.13.2.9-2

The factored bearing resistance is:

$$R_r = \phi_{bb} \cdot R_n$$

$$\phi_{bb} = 0.80 \quad (\text{Design Step 4.1})$$

$$R_r = 39.00 \text{ K}$$

The controlling minimum Strength I resultant bolt force was previously computed:

$$P_{r_str} = 37.98 \text{ K} < R_r = 39.00 \text{ K} \quad \text{OK}$$



Bearing Resistance at Web Bolt Holes

Should the bearing resistance be exceeded, it is recommended that the edge distance be increased slightly in lieu of increasing the number of bolts or thickening the web.

Fatigue of Splice Plates:

For load-induced fatigue considerations, each detail shall satisfy:

$$\gamma \cdot (\Delta f) \leq (\Delta F)_n$$

SEquation
6.6.1.2.2-1

Fatigue is checked at the bottom edge of the splice plates, which by inspection are subject to a net tensile stress.

The normal stresses at the bottom edge of the splice plates due to the total positive and negative fatigue-load web moments and the corresponding horizontal force resultants are as follows:

$$f = \frac{M_{\text{total}}}{S_{\text{pl}}} + \frac{H_w}{A_{\text{gross_wp}}}$$

From previous calculations:

$$S_{\text{pl}} = 240.00 \text{ in}^3$$

$$A_{\text{gross_wp}} = 30.00 \text{ in}^2$$

Case 1 - Positive Live Load:

From Design Step 4.6:

$$M_{\text{tot_fat_pos}} = 30.34 \text{ K}\cdot\text{ft}$$

$$H_{w_fat_pos} = 33.08 \text{ K}$$

$$f_{\text{fat_pos}} = \frac{M_{\text{tot_fat_pos}}}{S_{\text{pl}}} \cdot \left(12 \cdot \frac{\text{in}}{\text{ft}} \right) + \frac{H_{w_fat_pos}}{A_{\text{gross_wp}}}$$

$$f_{\text{fat_pos}} = 2.62 \text{ ksi}$$

Case 2 - Negative Live Load:

From Design Step 4.6:

$$M_{\text{tot_fat_neg}} = -28.24 \text{ K}\cdot\text{ft}$$

$$H_{\text{w_fat_neg}} = -23.76 \text{ K}$$

$$f_{\text{fat_neg}} = \frac{M_{\text{tot_fat_neg}}}{S_{\text{pl}}} \cdot \left(12 \cdot \frac{\text{in}}{\text{ft}}\right) + \frac{H_{\text{w_fat_neg}}}{A_{\text{gross_wp}}}$$

$$f_{\text{fat_neg}} = -2.20 \text{ ksi}$$

The total fatigue-load stress range at the bottom edge of the web splice plates is therefore:

$$\gamma\Delta f = |f_{\text{fat_pos}}| + |f_{\text{fat_neg}}|$$

$$\gamma\Delta f = 4.82 \text{ ksi}$$

From Design Step 4.4, the fatigue resistance was determined as:

$$\Delta F_n = 8.00 \text{ ksi}$$

The fatigue check is now completed as follows:

$$\gamma\Delta f = 4.82 \text{ ksi} < \Delta F_n = 8.00 \text{ ksi} \quad \text{OK}$$

Design Step 4.8 - Draw Schematic of Final Bolted Field Splice Design

Figure 4-11 shows the final bolted field splice as determined in this design example.

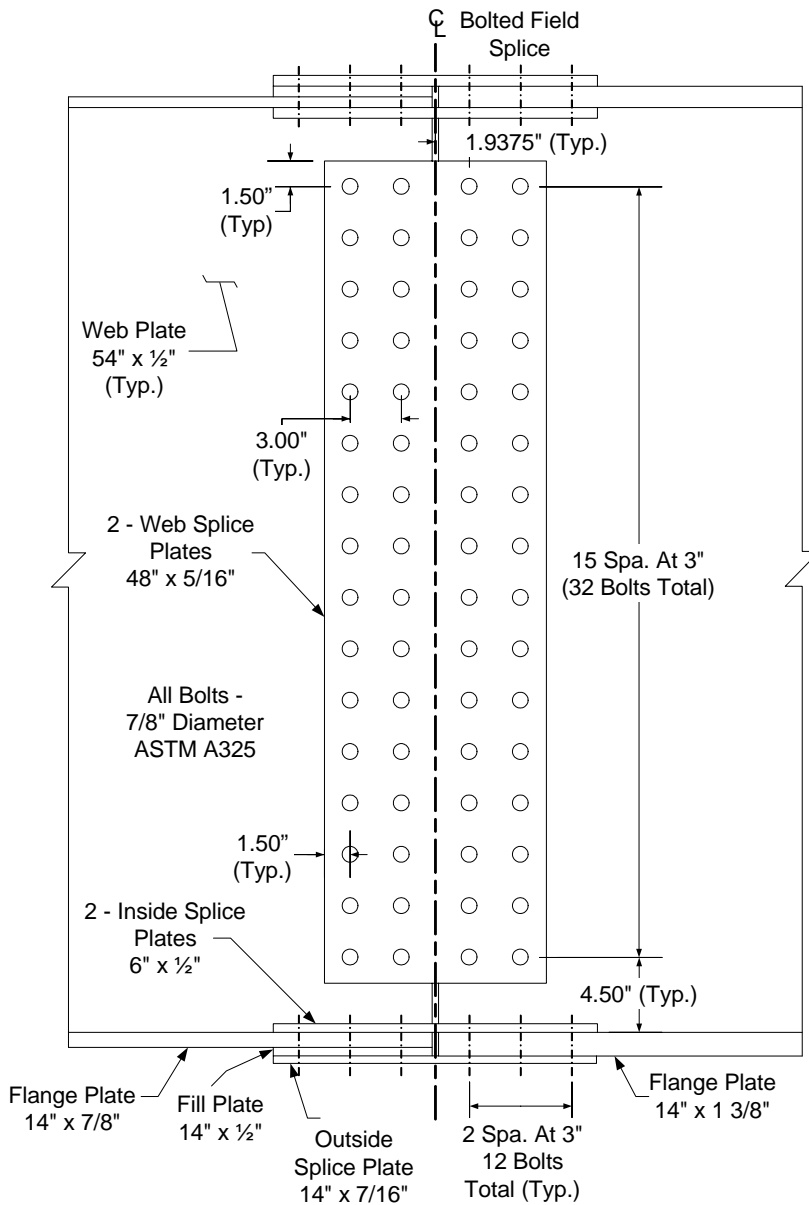

Figure 4-11 Final Bolted Field Splice Design

Miscellaneous Steel Design Example Design Step 5

Table of Contents

	<u>Page</u>
Design Step 5.1 - Design Shear Connectors	2
Design Step 5.2 - Design Bearing Stiffeners	10
Design Step 5.3 - Design Welded Connections	16
Design Step 5.4 - Design Cross-frames	21
(It should be noted that Design Step 5.4 presents a narrative description rather than design computations.)	

Design Step 5 consists of various design computations associated with the steel girder but not necessarily required to design the actual plates of the steel girder. Such miscellaneous steel design computations include the following:

1. Shear connectors
2. Bearing stiffeners
3. Welded connections
4. Diaphragms and cross-frames
5. Lateral bracing
6. Girder camber

For this design example, computations for the shear connectors, a bearing stiffener, a welded connection, and a cross-frame will be presented. The other features must also be designed, but their design computations are not included in this design example.

The following units are defined for use in this design example:

$$K = 1000\text{lb} \quad \text{ksi} = \frac{K}{\text{in}^2} \quad \text{ksf} = \frac{K}{\text{ft}^2}$$

Refer to Design Step 1 for introductory information about this design example. Additional information is presented about the design assumptions, methodology, and criteria for the entire bridge, including the design features included in this design step.

Design Step 5.1 - Design Shear Connectors

Since the steel girder has been designed as a composite section, shear connectors must be provided at the interface between the concrete deck slab and the steel section to resist the interface shear. For continuous composite bridges, shear connectors are normally provided throughout the length of the bridge. In the negative flexure region, since the longitudinal reinforcement is considered to be a part of the composite section, shear connectors must be provided.

S6.10.7.4.1

Studs or channels may be used as shear connectors. For this design example, stud shear connectors are being used throughout the length of the bridge. The shear connectors must permit a thorough compaction of the concrete to ensure that their entire surfaces are in contact with the concrete. In addition, the shear connectors must be capable of resisting both horizontal and vertical movement between the concrete and the steel.

S6.10.7.4.1a

The following figure shows the stud shear connector proportions, as well as the location of the stud head within the concrete deck.

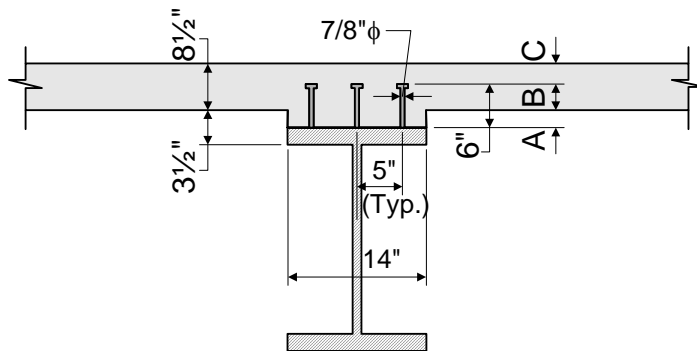

Figure 5-1 Stud Shear Connectors

Shear Connector Embedment			
Flexure Region	A	B	C
Positive	2.875"	3.125"	5.375"
Intermediate	2.25"	3.75"	4.75"
Negative	1.00"	5.00"	3.50"

Table 5-1 Shear Connector Embedment



Shear Connector Layout

It is common to use several stud shear connectors per transverse row along the top flange of the girder. The number of shear connectors per transverse row will depend on the top flange width. Refer to *S6.10.7.4.1c* for transverse spacing requirements.



Shear Connector Length

The stud shear connector length is commonly set such that its head is located near the middle of the deck slab. Refer to *S6.10.7.4.1d* for shear connector embedment requirements.

The ratio of the height to the diameter of a stud shear connector must not be less than 4.0. For this design example, the ratio is computed based on the dimensions presented in Figure 5-1, as follows:

$$\text{Height}_{\text{stud}} = 6.0 \cdot \text{in}$$

$$\text{Diameter}_{\text{stud}} = 0.875 \cdot \text{in}$$

$$\frac{\text{Height}_{\text{stud}}}{\text{Diameter}_{\text{stud}}} = 6.86 \quad \text{OK}$$

The pitch of the shear connectors must be determined to satisfy the fatigue limit state as specified in *S6.10.7.4.2* and *S6.10.7.4.3*, as applicable. The resulting number of shear connectors must not be less than the number required to satisfy the strength limit states as specified in *S6.10.7.4.4*.

The pitch, p , of the shear connectors must satisfy the following equation:

$$p \leq \frac{n \cdot Z_r \cdot I}{V_{sr} \cdot Q}$$

The parameters I and Q are based on the short-term composite section and are determined using the deck within the effective flange width.

S6.10.7.4.1a

S6.10.7.4.1b

In the positive flexure region:

$$n = 3 \quad (\text{see Figure 5-1})$$

$$I = 66340.3 \cdot \text{in}^4 \quad (\text{see Table 3-4})$$

$$Q = \left[\frac{(8.0 \cdot \text{in}) \cdot (103.0 \cdot \text{in})}{8} \right] \cdot (62.375 \cdot \text{in} - 50.765 \cdot \text{in})$$

$$Q = 1195.8 \text{in}^3$$

In the positive flexure region, the maximum fatigue live load shear range is located at the abutment. The factored value is computed as follows:

$$V_{SR} = 0.75 \cdot (41.45 \cdot K + 5.18 \cdot K)$$

$$V_{SR} = 34.97 K$$

(see live load analysis computer run)

$$Z_r = \alpha \cdot d^2 \geq \frac{5.5 \cdot d^2}{2}$$

$$N = 82125000 \quad (\text{see Design Step 3.14 at location of maximum positive flexure})$$

$$\alpha = 34.5 - 4.28 \cdot \log(N)$$

$$\alpha = 0.626$$

$$d = 0.875 \text{ in}$$

$$\alpha \cdot d^2 = 0.48 \quad \frac{5.5 \cdot d^2}{2} = 2.11$$

$$\text{Therefore, } Z_r = 2.11 \cdot K$$

$$p = \frac{n \cdot Z_r \cdot I}{V_{SR} \cdot Q} \quad p = 10.04 \text{ in}$$

S6.10.3.1.1b

S6.10.7.4.2

S6.6.1.2.5

In the negative flexure region:

$$n = 3 \quad (\text{see Figure 5-1})$$

In the negative flexure region, the parameters I and Q may be determined using the reinforcement within the effective flange width for negative moment, unless the concrete slab is considered to be fully effective for negative moment in computing the longitudinal range of stress, as permitted in S6.6.1.2.1. For this design example, I and Q are assumed to be computed considering the concrete slab to be fully effective.

$$I = 130196.1 \cdot \text{in}^4 \quad (\text{see Table 3-5})$$

$$Q = \left[\frac{(8.0 \cdot \text{in}) \cdot (103.0 \cdot \text{in})}{8} \right] \cdot (64.250 \cdot \text{in} - 46.702 \cdot \text{in})$$

$$Q = 1807.4 \text{in}^3$$

$$V_{\text{SR}} = 0.75 \cdot (0.00 \cdot \text{K} + 46.53 \cdot \text{K})$$

$$V_{\text{SR}} = 34.90 \text{K}$$

(see Table 3-1 and live load analysis computer run)

$$Z_r = \alpha \cdot d^2 \geq \frac{5.5 \cdot d^2}{2}$$

$$Z_r = 2.11 \cdot \text{K} \quad (\text{see previous computation})$$

$$p = \frac{n \cdot Z_r \cdot I}{V_{\text{SR}} \cdot Q} \quad p = 13.07 \text{in}$$

Therefore, based on the above pitch computations to satisfy the fatigue limit state, use the following pitch throughout the entire girder length:

$$p = 10 \cdot \text{in}$$

SC6.10.7.4.1b

S6.10.7.4.2



Shear Connector Pitch

The shear connector pitch does not necessarily have to be the same throughout the entire length of the girder. Many girder designs use a variable pitch, and this can be economically beneficial.

However, for this design example, the required pitch for fatigue does not vary significantly over the length of the bridge. Therefore, a constant shear connector pitch of 10 inches will be used.

In addition, the shear connectors must satisfy the following pitch requirements:

$$p \leq 24 \cdot \text{in} \quad \text{OK}$$

$$p \geq 6 \cdot d$$

$$d = 0.875 \cdot \text{in} \quad 6 \cdot d = 5.25 \text{in} \quad \text{OK}$$

For transverse spacing, the shear connectors must be placed transversely across the top flange of the steel section and may be spaced at regular or variable intervals.

Stud shear connectors must not be closer than 4.0 stud diameters center-to-center transverse to the longitudinal axis of the supporting member.

$$4 \cdot d = 3.50 \text{in}$$

$$\text{Spacing}_{\text{transverse}} = 5.0 \cdot \text{in} \quad (\text{see Figure 5-1}) \quad \text{OK}$$

In addition, the clear distance between the edge of the top flange and the edge of the nearest shear connector must not be less than 1.0 inch.

$$\text{Distance}_{\text{clear}} = \frac{14 \text{in}}{2} - 5 \text{in} - \frac{d}{2} \quad (\text{see Figure 5-1})$$

$$\text{Distance}_{\text{clear}} = 1.56 \text{in} \quad \text{OK}$$

The clear depth of concrete cover over the tops of the shear connectors should not be less than 2.0 inches, and shear connectors should penetrate at least 2.0 inches into the deck. Based on the shear connector penetration information presented in Table 5-1, both of these requirements are satisfied.

S6.10.7.4.1b

S6.10.7.4.1c

S6.10.7.4.1d

For the strength limit state, the factored resistance of the shear connectors, Q_r , is computed as follows:

$$Q_r = \phi_{sc} \cdot Q_n$$

$$\phi_{sc} = 0.85$$

The nominal shear resistance of one stud shear connector embedded in a concrete slab is computed as follows:

$$Q_n = 0.5 \cdot A_{sc} \cdot \sqrt{f'_c \cdot E_c} \leq A_{sc} \cdot F_u$$

$$A_{sc} = \pi \cdot \frac{d^2}{4} \quad A_{sc} = 0.601 \text{ in}^2$$

$$f'_c = 4.0 \cdot \text{ksi} \quad (\text{see Design Step 3.1})$$

$$E_c = 3834 \cdot \text{ksi} \quad (\text{see Design Step 3.3})$$

$$F_u = 60.0 \cdot \text{ksi}$$

$$0.5 \cdot 0.601 \cdot \sqrt{4.0 \cdot 3834} = 37.21 \text{ K}$$

$$0.601 \cdot 60.0 = 36.06 \text{ K}$$

$$\text{Therefore, } Q_n = 36.06 \cdot \text{K}$$

$$Q_r = \phi_{sc} \cdot Q_n$$

$$\text{Therefore, } Q_r = 30.65 \text{ K}$$

The number of shear connectors provided between the section of maximum positive moment and each adjacent point of 0.0 moment or between each adjacent point of 0.0 moment and the centerline of an interior support must not be less than the following:

$$n = \frac{V_h}{Q_r}$$

The total horizontal shear force, V_h , between the point of maximum positive moment and each adjacent point of 0.0 moment is equal to the lesser of the following:

$$V_h = 0.85 \cdot f'_c \cdot b \cdot t_s$$

or

$$V_h = F_{yw} \cdot D \cdot t_w + F_{yt} \cdot b_t \cdot t_t + F_{yc} \cdot b_f \cdot t_f$$

S6.10.7.4.4

S6.10.7.4.4a

S6.5.4.2

S6.10.7.4.4c

S5.4.2.1

S5.4.2.4

S6.4.4

S6.10.7.4.4a

S6.10.7.4.4b

where	$f_c = 4.0 \text{ ksi}$	(see Design Step 3.1)	S5.4.2.1
	$b = 103.0 \text{ in}$	(see Design Step 3.3)	
	$t_s = 8.0 \text{ in}$	(see Design Step 3.1)	
	$F_{yw} = 50 \text{ ksi}$	(see Design Step 3.1)	STable 6.4.1-1
	$D = 54 \text{ in}$	(see Design Step 3.18)	
	$t_w = 0.50 \text{ in}$	(see Design Step 3.18)	
	$F_{yt} = 50 \text{ ksi}$	(see Design Step 3.1)	STable 6.4.1-1
	$b_t = 14 \text{ in}$	(see Design Step 3.18)	
	$t_t = 0.875 \text{ in}$	(see Design Step 3.18)	
	$F_{yc} = 50 \text{ ksi}$	(see Design Step 3.1)	STable 6.4.1-1
	$b_f = 14 \text{ in}$	(see Design Step 3.18)	
	$t_f = 0.625 \text{ in}$	(see Design Step 3.18)	

$$0.85 \cdot f_c \cdot b \cdot t_s = 2802 \text{ K}$$

$$F_{yw} \cdot D \cdot t_w + F_{yt} \cdot b_t \cdot t_t + F_{yc} \cdot b_f \cdot t_f = 2400 \text{ K}$$

$$\text{Therefore, } V_h = 2400 \cdot \text{K}$$

Therefore, the number of shear connectors provided between the section of maximum positive moment and each adjacent point of 0.0 moment must not be less than the following:

$$n = \frac{V_h}{Q_r}$$

$$n = 78.3$$

The distance between the end of the girder and the location of maximum positive moment is approximately equal to:

$$L = 48.0 \text{ ft} \quad (\text{see Table 3-7})$$

Similarly the distance between the section of the maximum positive moment and the point of dead load contraflexure is approximately equal to:

$$L = 83.6 \text{ ft} - 48.0 \text{ ft} \quad (\text{see Table 3-7})$$

$$L = 35.6 \text{ ft}$$

S6.10.7.4.4a

Using a pitch of 10 inches, as previously computed for the fatigue limit state, and using the minimum length computed above, the number of shear connectors provided is as follows:

$$n = 3 \cdot \frac{L \cdot \left(12 \frac{\text{in}}{\text{ft}}\right)}{p}$$

$$L = 35.6 \text{ ft} \quad p = 10 \text{ in}$$

$$n = 128.2 \quad \text{OK}$$

For continuous span composite sections, the total horizontal shear force, V_h , between each adjacent point of 0.0 moment and the centerline of an interior support is equal to the following:

$$V_h = A_r \cdot F_{yr}$$

$$\text{where } A_r = 12.772 \cdot \text{in}^2 \quad (\text{see Design Step 3.3})$$

$$F_{yr} = 60 \cdot \text{ksi} \quad (\text{see Design Step 3.1})$$

$$V_h = A_r \cdot F_{yr}$$

$$V_h = 766 \text{ K}$$

Therefore, the number of shear connectors provided between each adjacent point of 0.0 moment and the centerline of an interior support must not be less than the following:

$$n = \frac{V_h}{Q_r}$$

$$n = 25.0$$

The distance between the point of dead load contraflexure and the centerline of the interior support is approximately equal to:

$$L = 120 \cdot \text{ft} - 83.6 \cdot \text{ft} \quad (\text{see Table 3-7})$$

$$L = 36.4 \text{ ft}$$

Using a pitch of 10 inches, as previously computed for the fatigue limit state, the number of shear connectors provided is as follows:

$$n = 3 \cdot \frac{L \cdot \left(12 \frac{\text{in}}{\text{ft}}\right)}{p}$$

$$p = 10 \text{ in}$$

$$n = 131.0 \quad \text{OK}$$

S6.10.7.4.4b

S6.10.7.4.4a

Therefore, using a pitch of 10 inches for each row, with three stud shear connectors per row, throughout the entire length of the girder satisfies both the fatigue limit state requirements of *S6.10.7.4.1* and *S6.10.7.4.2* and the strength limit state requirements of *S6.10.7.4.4*.

Therefore, use a shear stud spacing as illustrated in the following figure.

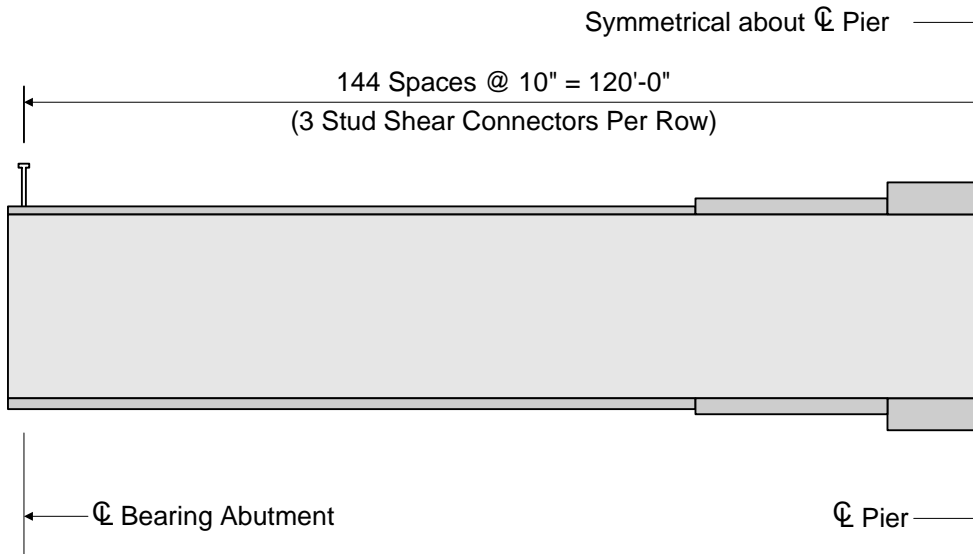

Figure 5-2 Shear Connector Spacing

Design Step 5.2 - Design Bearing Stiffeners

Bearing stiffeners are required to resist the bearing reactions and other concentrated loads, either in the final state or during construction.

For plate girders, bearing stiffeners are required to be placed on the webs at all bearing locations and at all locations supporting concentrated loads.

Therefore, for this design example, bearing stiffeners are required at both abutments and at the pier. The following design of the abutment bearing stiffeners illustrates the bearing stiffener design procedure.

The bearing stiffeners in this design example consist of one plate welded to each side of the web. The connections to the web will be designed to transmit the full bearing force due to factored loads and is presented in Design Step 5.3.

S6.10.8.2.1

The stiffeners extend the full depth of the web and, as closely as practical, to the outer edges of the flanges.

Each stiffener will either be milled to fit against the flange through which it receives its reaction or attached to the flange by a full penetration groove weld.

The following figure illustrates the bearing stiffener layout at the abutments.

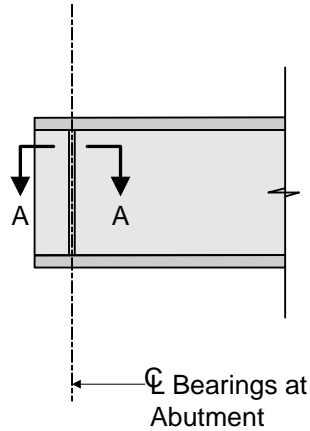

Partial Girder Elevation at Abutment

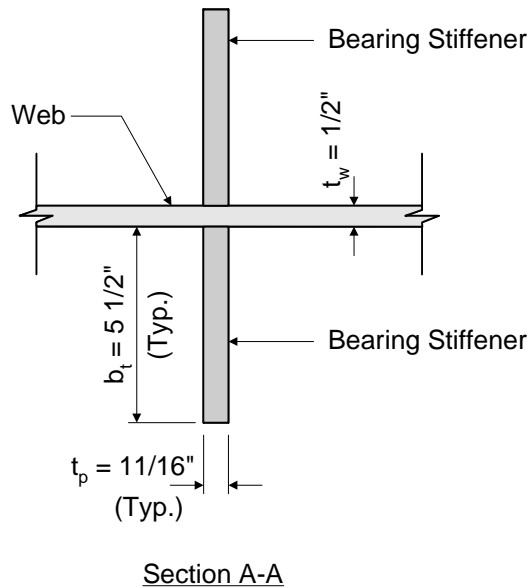

Section A-A

Figure 5-3 Bearing Stiffeners at Abutments



Bearing Stiffener Plates

Bearing stiffeners usually consist of one plate connected to each side of the web. This is generally a good starting assumption for the bearing stiffener design. Then, if this configuration does not provide sufficient resistance, two plates can be used on each side of the web.

The projecting width, b_t , of each bearing stiffener element must satisfy the following equation. This provision is intended to prevent local buckling of the bearing stiffener plates.

$$b_t \leq 0.48 \cdot t_p \cdot \sqrt{\frac{E}{F_{ys}}}$$

$$t_p = \frac{11}{16} \cdot \text{in} \quad (\text{see Figure 5-3})$$

$$E = 29000 \cdot \text{ksi}$$

$$F_{ys} = 50 \cdot \text{ksi}$$

$$0.48 \cdot t_p \cdot \sqrt{\frac{E}{F_{ys}}} = 7.95 \text{ in}$$

$$b_t = 5.5 \cdot \text{in} \quad (\text{see Figure 5-3}) \quad \text{OK}$$

The bearing resistance must be sufficient to resist the factored reaction acting on the bearing stiffeners. The factored bearing resistance, B_r , is computed as follows:

$$B_r = \phi_b \cdot A_{pn} \cdot F_{ys}$$

$$\phi_b = 1.00$$

Part of the stiffener must be clipped to clear the web-to-flange weld. Thus the area of direct bearing is less than the gross area of the stiffener. The bearing area, A_{pn} , is taken as the area of the projecting elements of the stiffener outside of the web-to-flange fillet welds but not beyond the edge of the flange. This is illustrated in the following figure:

S6.10.8.2.2

S6.4.1

STable 6.4.1-1

S6.10.8.2.3

S6.5.4.2

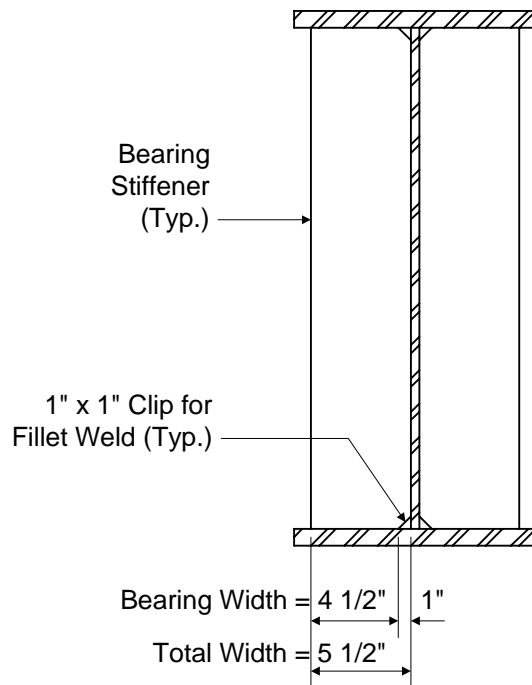

Figure 5-4 Bearing Width

$$b_{brg} = b_t - 1.0 \text{ in}$$

$$b_{brg} = 4.5 \text{ in}$$

$$A_{pn} = 2b_{brg} \cdot t_p$$

$$A_{pn} = 6.19 \text{ in}^2$$

$$F_{ys} = 50 \text{ ksi}$$

$$B_r = \phi_b \cdot A_{pn} \cdot F_{ys}$$

$$B_r = 309.4 \text{ K}$$

The factored bearing reaction at the abutment is computed as follows, using load factors as presented in *S*Table 3.4.1-1 and *S*Table 3.4.1-2 and using reactions obtained from a computer analysis run:

$$\text{Reaction}_{\text{Factored}} = (1.25 \cdot 68.7 \cdot \text{K}) + (1.50 \cdot 11.0 \cdot \text{K}) \dots \\ + (1.75 \cdot 110.5 \cdot \text{K})$$

$$\text{Reaction}_{\text{Factored}} = 295.8 \text{ K}$$

Therefore, the bearing stiffener at the abutment satisfies the bearing resistance requirements.

The final bearing stiffener check relates to the axial resistance of the bearing stiffeners. The factored axial resistance is determined as specified in S6.9.2.1. The radius of gyration is computed about the midthickness of the web, and the effective length is taken as 0.75D, where D is the web depth.

S6.10.8.2.4
S6.10.8.2.4a

For stiffeners consisting of two plates welded to the web, the effective column section consists of the two stiffener elements, plus a centrally located strip of web extending not more than $9t_w$ on each side of the stiffeners. This is illustrated in the following figure:

S6.10.8.2.4b

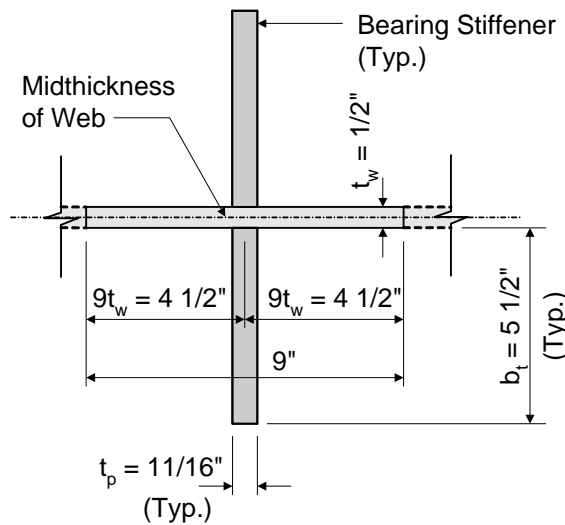

Figure 5-5 Bearing Stiffener Effective Section

$$P_r = \phi_c \cdot P_n$$

S6.9.2.1

$$\phi_c = 0.90$$

S6.5.4.2

$$\lambda = \left(\frac{k \cdot l}{r_s \cdot \pi} \right)^2 \cdot \frac{F_y}{E}$$

S6.9.4.1

$$kl = (0.75) \cdot (54\text{in})$$

S6.10.8.2.4a

$$I_s = \frac{[0.6875\text{in} \cdot (11.5\text{in})^3] + [8.3125\text{in} \cdot (0.5\text{in})^3]}{12}$$

S6.10.8.2.4b

$$I_s = 87.22\text{in}^4$$

$$A_s = (0.6875\text{in} \cdot 11.5\text{in}) + (8.3125\text{in} \cdot 0.5\text{in})$$

$$A_s = 12.06\text{in}^2$$

$$r_s = \sqrt{\frac{I_s}{A_s}}$$

$$r_s = 2.69\text{in}$$

$$F_y = 50\text{ksi}$$

$$\lambda = \left(\frac{kl}{r_s \cdot \pi} \right)^2 \cdot \frac{F_y}{E}$$

$$\lambda = 0.0396$$

$$\text{Therefore, } \lambda \leq 2.25$$

$$\text{Therefore, } P_n = 0.66^\lambda F_y \cdot A_s$$

$$P_n = 593.3\text{K}$$

$$P_r = \phi_c \cdot P_n$$

$$P_r = 533.9\text{K}$$

$$\text{Reaction}_{\text{Factored}} = 295.8\text{K}$$

Therefore, the bearing stiffener at the abutment satisfies the axial bearing resistance requirements.

The bearing stiffener at the abutment satisfies all bearing stiffener requirements. Therefore, use the bearing stiffener as presented in Figures 5-3 and 5-4.

S6.10.8.2.4b

S6.9.4.1

S6.9.4.1

S6.9.2.1

Design Step 5.3 - Design Welded Connections

Welded connections are required at several locations on the steel superstructure. Base metal, weld metal, and welding design details must conform to the requirements of the *ANSI/AASHTO/AWS Bridge Welding Code D1.5*.

For this design example, two fillet welded connection designs will be presented using E70 weld metal:

1. Welded connection between the bearing stiffeners and the web.
2. Welded connection between the web and the flanges.

For the welded connection between the bearing stiffeners and the web, the fillet weld must resist the factored reaction computed in Design Step 5.2.

$$\text{Reaction}_{\text{Factored}} = 295.8 \text{ K}$$

Assume a fillet weld thickness of 1/4 inches.

$$\text{Thickness}_{\text{Weld}} = 0.25 \text{ in}$$



Fillet Weld Thickness

In most cases, the minimum weld thickness, as specified in Table 5-2, provides a welded connection that satisfies all design requirements. Therefore, the minimum weld thickness is generally a good starting point when designing a fillet weld.

The resistance of the fillet weld in shear is the product of the effective area and the factored resistance of the weld metal. The factored resistance of the weld metal is computed as follows:

$$R_r = 0.6 \cdot \phi_{e2} \cdot F_{exx}$$

$$\phi_{e2} = 0.80$$

$$F_{e70} = 70 \cdot \text{ksi}$$

$$R_r = 0.6 \cdot \phi_{e2} \cdot F_{e70}$$

$$R_r = 33.60 \text{ ksi}$$

S6.13.3

S6.13.3.2.4b

S6.5.4.2

SC6.13.3.2.1

S6.13.3.2.4b

The effective area equals the effective weld length multiplied by the effective throat. The effective throat is the shortest distance from the joint root to the weld face.

$$\text{Length}_{\text{Eff}} = 4 \cdot (54\text{in} - 2\text{in}) \qquad \text{Length}_{\text{Eff}} = 208.0\text{in}$$

$$\text{Throat}_{\text{Eff}} = \frac{\text{Thickness}_{\text{Weld}}}{\sqrt{2}} \qquad \text{Throat}_{\text{Eff}} = 0.177\text{in}$$

$$\text{Area}_{\text{Eff}} = \text{Length}_{\text{Eff}} \cdot \text{Throat}_{\text{Eff}} \qquad \text{Area}_{\text{Eff}} = 36.77\text{in}^2$$

The resistance of the fillet weld is then computed as follows:

$$\text{Resistance} = R_f \cdot \text{Area}_{\text{Eff}}$$

$$\text{Resistance} = 1235\text{K} \qquad \text{OK}$$

For material 0.25 inches or more in thickness, the maximum size of the fillet weld is 0.0625 inches less than the thickness of the material, unless the weld is designated on the contract documents to be built out to obtain full throat thickness.

For the fillet weld connecting the bearing stiffeners to the web, the bearing stiffener thickness is 11/16 inches and the web thickness is 1/2 inches. Therefore, the maximum fillet weld size requirement is satisfied.

The minimum size of fillet welds is as presented in Table 5-2. In addition, the weld size need not exceed the thickness of the thinner part joined.

Minimum Size of Fillet Welds	
Base Metal Thickness of Thicker Part Joined (T) (Inches)	Minimum Size of Fillet Weld (Inches)
$T \leq 3/4$	1/4
$T > 3/4$	5/16

Table 5-2 Minimum Size of Fillet Welds

In this case, the thicker part joined is the bearing stiffener plate, which is 11/16 inches thick. Therefore, based on Table 5-2, the minimum size of fillet weld is 1/4 inch, and this requirement is satisfied.

S6.13.3.3

S6.13.3.2.4b

S6.13.3.4

S6.13.3.4

S6.13.3.4-1

The minimum effective length of a fillet weld is four times its size and in no case less than 1.5 inches. Therefore, this requirement is also satisfied.

S6.13.3.5

Since all weld design requirements are satisfied, use a 1/4 inch fillet weld for the connection of the bearing stiffeners to the web.

For the welded connection between the web and the flanges, the fillet weld must resist a factored horizontal shear per unit length based on the following equation:

S6.13.3

$$v = \frac{V \cdot Q}{I}$$

This value is greatest at the pier, where the factored shear has its highest value.

The following computations are for the welded connection between the web and the top flange. The welded connection between the web and the bottom flange is designed in a similar manner.

The shear is computed based on the individual section properties and load factors for each loading, as presented in Design Steps 3.3 and 3.6:

For the noncomposite section, the factored horizontal shear is computed as follows:

$$V_{\text{Noncomp}} = (1.25 \cdot 114.7 \cdot K)$$

$$V_{\text{Noncomp}} = 143.4 K$$

$$Q_{\text{Noncomp}} = (14 \cdot \text{in} \cdot 2.5 \cdot \text{in}) \cdot (58.00 \cdot \text{in} - 28.718 \cdot \text{in})$$

$$Q_{\text{Noncomp}} = 1024.9 \text{ in}^3$$

$$I_{\text{Noncomp}} = 65426.6 \cdot \text{in}^4$$

$$v_{\text{Noncomp}} = \frac{V_{\text{Noncomp}} \cdot Q_{\text{Noncomp}}}{I_{\text{Noncomp}}} \quad v_{\text{Noncomp}} = 2.25 \frac{K}{\text{in}}$$

For the composite section, the factored horizontal shear is computed as follows:

$$V_{\text{Comp}} = (1.25 \cdot 16.4 \cdot K) + (1.50 \cdot 19.8 \cdot K) + (1.75 \cdot 131.4 \cdot K)$$

$$V_{\text{Comp}} = 280.1 K$$

$$Q_{\text{Comp}} = (14 \cdot \text{in} \cdot 2.5 \cdot \text{in}) \cdot (58.00 \cdot \text{in} - 32.668 \cdot \text{in})$$

$$Q_{\text{Comp}} = 886.6 \text{ in}^3$$

$$I_{\text{Comp}} = 79333.4 \cdot \text{in}^4$$

$$v_{\text{Comp}} = \frac{V_{\text{Comp}} \cdot Q_{\text{Comp}}}{I_{\text{Comp}}} \qquad v_{\text{Comp}} = 3.13 \frac{K}{\text{in}}$$

Based on the above computations, the total factored horizontal shear is computed as follows:

$$v_{\text{Total}} = v_{\text{Noncomp}} + v_{\text{Comp}}$$

$$v_{\text{Total}} = 5.38 \frac{K}{\text{in}}$$

Assume a fillet weld thickness of 5/16 inches.

$$\text{Thickness}_{\text{Weld}} = 0.3125 \text{ in}$$

The resistance of the fillet weld in shear is the product of the effective area and the factored resistance of the weld metal. The factored resistance of the weld metal was previously computed as follows:

$$R_r = 0.6 \cdot \phi_{e2} \cdot F_{e70} \qquad R_r = 33.60 \text{ ksi}$$

The effective area equals the effective weld length multiplied by the effective throat. The effective throat is the shortest distance from the joint root to the weld face. In this case, the effective area is computed per unit length, based on the use of one weld on each side of the web.

$$\text{Throat}_{\text{Eff}} = \frac{\text{Thickness}_{\text{Weld}}}{\sqrt{2}} \qquad \text{Throat}_{\text{Eff}} = 0.221 \text{ in}$$

$$\text{Area}_{\text{Eff}} = 2 \cdot \text{Throat}_{\text{Eff}} \qquad \text{Area}_{\text{Eff}} = 0.442 \frac{\text{in}^2}{\text{in}}$$

S6.13.3.2.4b

S6.13.3.3

The resistance of the fillet weld is then computed as follows:

$$\text{Resistance} = R_f \cdot \text{Area}_{\text{Eff}}$$

$$\text{Resistance} = 14.85 \frac{\text{K}}{\text{in}} \quad \text{OK}$$

For material 0.25 inches or more in thickness, the maximum size of the fillet weld is 0.0625 inches less than the thickness of the material, unless the weld is designated on the contract documents to be built out to obtain full throat thickness.

For the fillet weld connecting the web to the flanges, the web thickness is 0.5 inches, the minimum flange thickness is 0.625 inches, and the maximum flange thickness is 2.75 inches. Therefore, the maximum fillet weld size requirement is satisfied.

The minimum size of fillet welds is as presented in Table 5-2. In addition, the weld size need not exceed the thickness of the thinner part joined.

In this case, the thicker part joined is the flange, which has a minimum thickness of 0.625 inches and a maximum thickness of 2.75 inches. Therefore, based on Table 5-2, the minimum size of fillet weld is 5/16 inch, and this requirement is satisfied.

The minimum effective length of a fillet weld is four times its size and in no case less than 1.5 inches. Therefore, this requirement is also satisfied.

Since all weld design requirements are satisfied, use a 5/16 inch fillet weld for the connection of the web and the top flange. The welded connection between the web and the bottom flange is designed in a similar manner.

Load-induced fatigue must be considered in the base metal at a welded connection. Fatigue considerations for plate girders may include:

1. Welds connecting the shear studs to the girder.
2. Welds connecting the flanges and the web.
3. Welds connecting the transverse intermediate stiffeners to the girder.

The specific fatigue considerations depend on the unique characteristics of the girder design. Specific fatigue details and detail categories are explained and illustrated in *S*Table 6.6.1.2.3-1 and in *S*Figure 6.6.1.2.3-1.

S6.13.3.2.4b

S6.13.3.4

S6.13.3.4

S6.13.3.5

S6.6.1.2.5

In Design Step 3.14 for the positive moment region, the fatigue check is illustrated for the fillet-welded connection of the transverse intermediate stiffeners to the girder. This procedure must be considered for the base metal at welded connections.

Additional weld connection requirements are presented in S6.13.3 and in *ANSI/AASHTO/AWS Bridge Welding Code D1.5*.

Design Step 5.4 - Design Cross-frames

Diaphragms and cross-frames may be placed at the following locations along the bridge:

S6.7.4.1

- At the end of the structure
- Across interior supports
- Intermittently along the span



Diaphragm or Cross-frame Spacing

A common rule of thumb, based on previous editions of the AASHTO Specifications, is to use a maximum diaphragm or cross-frame spacing of 25 feet. Based on C6.7.4.1, the arbitrary requirement for a 25 foot maximum spacing has been replaced by a requirement for a rational analysis that will often result in the elimination of fatigue-prone attachment details.

For this design example, cross-frames are used at a spacing of 20 feet. The 20-foot spacing in this design example facilitates a reduction in the required flange thicknesses in the girder section at the pier.

The need for diaphragms or cross-frames must be investigated for:

- All stages of assumed construction procedures
- The final condition



Difference Between Diaphragms and Cross-frames

The difference between diaphragms and cross-frames is that diaphragms consist of a transverse flexural component, while cross-frames consist of a transverse truss framework.

Both diaphragms and cross-frames connect adjacent longitudinal flexural components.

When investigating the need for diaphragms or cross-frames and when designing them, the following must be considered:

- Transfer of lateral wind loads from the bottom of the girder to the deck and from the deck to the bearings
- Stability of the bottom flange for all loads when it is in compression
- Stability of the top flange in compression prior to curing of the deck
- Distribution of vertical dead and live loads applied to the structure

Diaphragms or cross-frames can be specified as either:

- Temporary - if they are required only during construction
- Permanent - if they are required during construction and in the bridge's final condition

At a minimum, the Specifications require that diaphragms and cross-frames be designed for the following:

- Transfer of wind loads according to the provisions of *S4.6.2.7*
- Applicable slenderness requirements in *S6.8.4* or *S6.9.3*

In addition, connection plates must satisfy the requirements of *S6.6.1.3.1*.



Cross-frame Types

K-type cross-frames are as shown in Figure 5-6, while X-type cross-frames have an X-shape configuration of angles or structural tees rather than a K-shape configuration of angles or structural tees.

A common rule of thumb is to use K-type cross-frames when the aspect ratio (that is, the ratio of the girder spacing to the girder depth) is greater than about 1.5 to 1 and to use X-type cross-frames when the aspect ratio is less than 1.5 to 1.

For this design example, cross-frames will be used.

Girder spacing: $S = 9.75 \cdot \text{ft}$ (see Figure 3-2)

Girder depth: $D = 4.9375 \cdot \text{ft}$ (see Figure 3-15)
(maximum value)

Aspect ratio: $\frac{S}{D} = 1.97$

Therefore, use K-type cross-frames.

The geometry of a typical K-type cross-frame for an intermediate cross-frame is illustrated in Figure 5-6.

As illustrated in Figure 5-6, the intersection of the centroidal axes of the two diagonals coincides with the centroidal axis of the bottom strut. In addition, the intersection of the centroidal axis of each diagonal and the centroidal axis of the top strut coincides with the vertical centerlines of the girders.

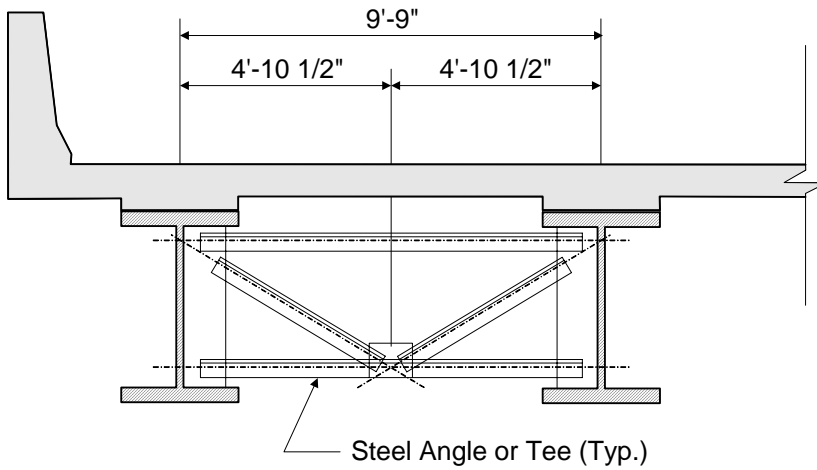

Figure 5-6 K-Type Cross-frame

Based on previous computations in Design Step 3.17 for the negative moment region, the unfactored wind load is computed as follows:

$$W = \frac{\eta \cdot \gamma \cdot P_D \cdot d}{2}$$

$$\eta = 1.0$$

$$\gamma = 1.40 \quad (\text{for Strength III Limit State})$$

$$P_D = 0.00529 \cdot \text{ksf} \quad (\text{see Design Step 3.17})$$

$$d = 4.9375\text{ft} \quad (\text{maximum value})$$

$$W = \frac{\eta \cdot \gamma \cdot P_D \cdot d}{2} \quad W = 0.0183 \frac{\text{K}}{\text{ft}}$$

C4.6.2.7.1

S1.3

STable 3.4.1-1

The horizontal wind force applied to the brace point may then be computed as specified in C4.6.2.7.1, as follows:

$$P_w = W \cdot L_b$$

$$W = 0.0183 \frac{\text{K}}{\text{ft}}$$

$$L_b = 20 \cdot \text{ft}$$

$$P_w = W \cdot L_b \quad P_w = 0.366 \text{K}$$

C4.6.2.7.1

For the design of the cross-frame members, the following checks should be made using the previously computed wind load:

- Slenderness
- Axial compression
- Flexure about the major axis
- Flexure about the minor axis
- Flexure and axial compression

Bearing Design Example Design Step 6

Table of Contents

	<u>Page</u>
Design Step 6.1 - Obtain Design Criteria	2
Design Step 6.2 - Select Optimum Bearing Type	2
Design Step 6.3 - Select Preliminary Bearing Properties	3
Design Step 6.4 - Select Design Method (A or B)	3
Design Step 6.5 - Compute Shape Factor	4
Design Step 6.6 - Check Compressive Stress	5
Design Step 6.7 - Check Compressive Deflection	5
Design Step 6.8 - Check Shear Deformation	7
Design Step 6.9 - Check Rotation or Combined Compression and Rotation	8
Design Step 6.10 - Check Stability	9
Design Step 6.11 - Check Reinforcement	9
Design Step 6.12 - Design for Anchorage	10
Design Step 6.13 - Design Anchorage for Fixed Bearing	12
Design Step 6.14 - Draw Schematic of Final Bearing Design	15

Design Step 6.1 - Obtain Design Criteria

For this bearing design example, an abutment bearing was chosen. It was decided that the abutment would have expansion bearings. Therefore, the bearing design will be for an expansion bearing.

Refer to Design Step 1 for introductory information about this design example. Additional information is presented about the design assumptions, methodology, and criteria for the entire bridge, including the bearing design.

The following units are defined for use in this design example:

$$K = 1000\text{lb} \quad \text{ksi} = \frac{K}{\text{in}^2}$$

For bearing design, the required design criteria includes:

1. Longitudinal and transverse movement
2. Longitudinal, transverse, and vertical rotation
3. Longitudinal, transverse, and vertical loads

Most of the above information is typically obtained from the superstructure design software output, which is the case for this bearing design (first trial of girder design):

$DL_{\text{serv}} = 78.4K$	Service I limit state dead load
$LL_{\text{serv}} = 110.4K$	Service I limit state live load (including dynamic load allowance)
$\theta_{\text{sx}} = 0.0121\text{rad}$	Service I limit state total rotation about the transverse axis (see Figure 6-1)
$P_{\text{sd}} = 67.8K$	Strength limit state minimum vertical force due to permanent loads (used in Design Step 6.12)

Design Step 6.2 - Select Optimum Bearing Type

Selecting the optimum bearing type depends on the load, movement capabilities, and economics. Refer to *S*Table 14.6.2-1 and *S*Figure 14.6.2-1 for guidance on selecting the most practical bearing type. For the abutment bearing design, a steel-reinforced elastomeric bearing was selected. If the loads were considerably larger, pot bearings, which are more expensive than elastomeric bearings, would be an option.

S14.6.2

Design Step 6.3 - Select Preliminary Bearing Properties

Once the most practical bearing type has been selected, the preliminary bearing properties must be defined. The bearing properties are obtained from the Specifications, as well as from past experience. The following preliminary bearing properties were selected:

Bearing Pad Configuration

Pad length (bridge longitudinal direction): $L_{\text{pad}} = 14\text{in}$

Pad width (bridge transverse direction): $W_{\text{pad}} = 15\text{in}$

Elastomer cover thickness: $h_{\text{rcover}} = 0.25\text{in}$

Elastomer internal layer thickness: $h_{\text{rinternal}} = 0.375\text{in}$

Number of steel reinforcement layers: $N_{\text{stlayers}} = 9$

Steel reinforcement thickness: $h_{\text{reinf}} = 0.1196\text{in}$

Material Properties

Elastomer hardness: $H_{\text{shoreA}} = 50$

Elastomer shear modulus: $G = 0.095\text{ksi}$

Elastomer creep deflection at 25 years divided by the instantaneous deflection: $C_d = 0.25$

Steel reinforcement yield strength: $F_y = 50\text{ksi}$

Design Step 6.4 - Select Design Method (A or B)

For this design example, Method A will be used. Method A usually results in a bearing with a lower capacity than a bearing designed with Method B. However, Method B requires additional testing and quality control. Method A is described in S14.7.6, while Method B is described in S14.7.5.

S14.7.6.2 &
S14.7.5.2

S14.7.5.2-1

S14.7.5.2-1

C14.7.5.1

Design Step 6.5 - Compute Shape Factor

The shape factor for individual elastomer layers is the plan area divided by the area of perimeter free to bulge.

S14.7.6.1 &
S14.7.5.1

For steel-reinforced elastomeric bearings, the following requirements must be met prior to calculating the shape factor:

S14.7.6.1 &
S14.7.5.1

1. All internal layers of elastomer must be the same thickness.
2. The thickness of the cover layers cannot exceed 70 percent of the thickness of the internal layers.

From Design Step 6.3, all internal elastomer layers are the same thickness, which satisfies Requirement 1. The following calculation verifies that Requirement 2 is satisfied:

$$0.70 \cdot h_{\text{rinternal}} = 0.26 \text{ in}$$

$$h_{\text{rcover}} = 0.25 \text{ in} \quad \text{OK}$$

For rectangular bearings without holes, the shape factor for the *i*th layer is:

S14.7.5.1

$$S_i = \frac{L \cdot W}{2 \cdot h_{ri} \cdot (L + W)}$$

The shape factor for the cover layers is then:

$$S_{\text{cov}} = \frac{L_{\text{pad}} \cdot W_{\text{pad}}}{2 \cdot h_{\text{rcover}} \cdot (L_{\text{pad}} + W_{\text{pad}})}$$

$$S_{\text{cov}} = 14.48$$

The shape factor for the internal layers is then:

$$S_{\text{int}} = \frac{L_{\text{pad}} \cdot W_{\text{pad}}}{2 \cdot h_{\text{rinternal}} \cdot (L_{\text{pad}} + W_{\text{pad}})}$$

$$S_{\text{int}} = 9.66$$

Design Step 6.6 - Check Compressive Stress

The compressive stress check limits the compressive stress in the elastomer at the service limit state as follows:

$$\sigma_s \leq 1.0 \text{ksi} \quad \text{and} \quad \sigma_s \leq 1.0 \cdot G \cdot S$$

The compressive stress is taken as the total reaction at one of the abutment bearings for the service limit state divided by the elastomeric pad plan area. The service limit state dead and live load reactions are obtained from the Opus superstructure output. The shape factor used in the above equation should be for the thickest elastomer layer.

Service I limit state dead load: $DL_{serv} = 78.4K$

Service I limit state live load
(including dynamic load allowance): $LL_{serv} = 110.4K$

$$\sigma_s = \frac{DL_{serv} + LL_{serv}}{(L_{pad} \cdot W_{pad})}$$

$$\sigma_s = 0.899 \text{ksi}$$

$$1.0 \cdot G \cdot S_{int} = 0.917 \text{ksi} \quad \text{OK}$$

The service average compressive stress due to live load only will also be computed at this time. It will be needed in Design Step 6.11. Again, the service limit state live load value was obtained from Opus superstructure output.

$$\sigma_L = \frac{LL_{serv}}{(L_{pad} \cdot W_{pad})}$$

$$\sigma_L = 0.526 \text{ksi}$$

Design Step 6.7 - Check Compressive Deflection

The compressive deflection due to the total load at the service limit state is obtained from the following equation:

$$\delta = \sum \varepsilon_j \cdot h_{rj}$$

S14.7.6.3.2

S14.7.5.3.3

For this design example, the instantaneous compressive strain was approximated from *C*Table 14.7.5.3.3-1 for 50 durometer reinforced bearings using a compressive stress of 0.899 ksi and a shape factor of 9.66.

$$\varepsilon_{int} = 0.04$$

The instantaneous deflection is then:

$$\delta_{inst} = 2 \cdot \varepsilon_{int} \cdot h_{rcover} + 8 \cdot \varepsilon_{int} \cdot h_{rinternal}$$

$$\delta_{inst} = 0.140 \text{ in}$$

The effects of creep should also be considered. For this design example, material-specific data is not available. Therefore, calculate the creep deflection value as follows:

$$\delta_{creep} = C_d \cdot \delta_{inst}$$

$$\delta_{creep} = 0.035 \text{ in}$$

The total deflection is then:

$$\delta_{total} = \delta_{inst} + \delta_{creep}$$

$$\delta_{total} = 0.175 \text{ in}$$

The initial compressive deflection in any layer of a steel-reinforced elastomeric bearing at the service limit state without dynamic load allowance shall not exceed $0.07h_{ri}$.

In order to reduce design steps, the above requirement will be checked using the deflection calculated for the service limit state including dynamic load allowance. If the compressive deflection is greater than $0.07h_{ri}$, then the deflection without dynamic load allowance would need to be calculated.

$$\delta_{int1layer} = \varepsilon_{int} \cdot h_{rinternal}$$

$$\delta_{int1layer} = 0.015 \text{ in}$$

$$0.07h_{rinternal} = 0.026 \text{ in} \quad \text{OK}$$

*C*Table
14.7.5.3.3-1

S14.7.5.3.3

S*Table* 14.7.5.2-1

S14.7.6.3.3

Design Step 6.8 - Check Shear Deformation

The shear deformation is checked to ensure that the bearing is capable of allowing the anticipated horizontal bridge movement. Also, the shear deformation is limited in order to avoid rollover at the edges and delamination due to fatigue caused by cyclic expansion and contraction deformations. The horizontal movement for this bridge design example is based on thermal effects only. The thermal movement is taken from Design Step 7.6 for the controlling movement, which is contraction. Other criteria that could add to the shear deformation include construction tolerances, braking force, and longitudinal wind if applicable. One factor that can reduce the amount of shear deformation is the substructure deflection. Since the abutment height is relatively short and the shear deformation is relatively small, the abutment deflection will not be taken into account.

S14.7.6.3.4

C14.7.5.3.4

The bearing must satisfy:

$$h_{rt} \geq 2 \cdot \Delta_s$$

$$h_{rt} = 2 \cdot h_{rcover} + 8 \cdot h_{rinternal}$$

$$h_{rt} = 3.50 \text{ in}$$

$$\Delta_{contr} = 0.636 \text{ in} \quad \text{from Design Step 7.6 for thermal contraction}$$

$$\gamma_{TU} = 1.20 \quad \text{for the service limit state}$$

$$\Delta_s = \gamma_{TU} \cdot \Delta_{contr}$$

$$\Delta_s = 0.76 \text{ in}$$

$$2 \cdot \Delta_s = 1.53 \text{ in}$$

$$3.50 \text{ in} \geq 1.53 \text{ in} \quad \text{OK}$$

STable 3.4.1-1 & S3.4.1

Design Step 6.9 - Check Rotation or Combined Compression and Rotation

Since Design Method A was chosen, combined compression and rotation does not need to be checked. The rotation check ensures that no point in the bearing undergoes net uplift and is as follows:

$$\sigma_s \geq 0.5G \cdot S \cdot \left(\frac{L}{h_{ri}} \right)^2 \cdot \frac{\theta_{sx}}{n} \quad \text{(associated with rotation about transverse axis)}$$

and

$$\sigma_s \geq 0.5G \cdot S \cdot \left(\frac{W}{h_{ri}} \right)^2 \cdot \frac{\theta_{sz}}{n} \quad \text{(associated with rotation about longitudinal axis)}$$

$$\sigma_s = 0.899 \text{ ksi}$$

The service rotation due to the total load about the transverse axis was taken from Opis:

$$\theta_{sx} = 0.0121 \text{ rad}$$



Construction Tolerance

For spans over approximately 100 feet, it is good engineering practice to include an additional 0.005 radians of rotation about both pad axes to account for construction tolerances.

The number of interior layers is:

$$n = 8 + 0.5 + 0.5$$

$$0.5 \cdot G \cdot S_{int} \cdot \left(\frac{L_{pad}}{h_{rinternal}} \right)^2 \cdot \frac{\theta_{sx}}{(8 + 1)} = 0.859 \text{ ksi} \quad \text{OK}$$

The service rotation due to the total load about the longitudinal axis is negligible compared to the service rotation about the transverse axis. Therefore, the check about the longitudinal axis will be assumed to be negligible and is not computed in this bearing design example.

S14.7.6.3.5

S14.7.6.3.5d

S14.7.6.3.5d

Design Step 6.10 - Check Stability

The total thickness of the pad shall not exceed the least of L/3 or W/3.

S14.7.6.3.6

$$\frac{L_{\text{pad}}}{3} = 4.67 \text{ in} \quad \frac{W_{\text{pad}}}{3} = 5.00 \text{ in}$$

The total thickness of the pad based on the preliminary dimensions is:

$$h_{\text{total}} = 2 \cdot h_{\text{rcover}} + 8 \cdot h_{\text{rinternal}} + N_{\text{stlayers}} \cdot h_{\text{reinf}}$$

$$h_{\text{total}} = 4.5764 \text{ in} \quad \text{OK}$$

Design Step 6.11 - Check Reinforcement

The thickness of the steel reinforcement must be able to sustain the tensile stresses induced by compression in the bearing. The reinforcement thickness must also satisfy the requirements of the *AASHTO LRFD Bridge Construction Specifications*.

S14.7.6.3.7

S14.7.5.3.7

For the service limit state:

$$h_s \geq \frac{3h_{\text{max}} \cdot \sigma_s}{F_y}$$

$$h_{\text{max}} = h_{\text{rinternal}} \quad h_{\text{max}} = 0.375 \text{ in}$$

$$\sigma_s = 0.899 \text{ ksi} \quad F_y = 50 \text{ ksi}$$

$$\frac{3 \cdot h_{\text{max}} \cdot \sigma_s}{F_y} = 0.0202 \text{ in}$$

$$h_{\text{reinf}} = 0.1196 \text{ in} \quad \text{OK}$$

For the fatigue limit state:

$$h_s \geq \frac{2h_{\max} \cdot \sigma_L}{\Delta F_{TH}}$$

From Design Step 6.6, the service average compressive stress due to live load only is:

$$\sigma_L = 0.526 \text{ ksi}$$

$$\Delta F_{TH} = 24.0 \text{ ksi}$$

$$\frac{2 \cdot h_{\max} \cdot \sigma_L}{\Delta F_{TH}} = 0.0164 \text{ in}$$

$$h_{\text{reinf}} = 0.1196 \text{ in} \quad \text{OK}$$

STable 6.6.1.2.5-3

Design Step 6.12 - Design for Anchorage

The bearing pad must be secured against transverse horizontal movement if the factored shear force sustained by the deformed pad at the strength limit state exceeds one-fifth of the minimum vertical force due to permanent loads, P_{sd} .

S14.7.6.4

$$P_{sd} = 67.8K \quad \text{taken from Opis output}$$

The maximum factored shear force sustained by the deformed pad at the strength limit state is obtained from Design Step 7.6, adding wind on superstructure and wind on live load. The maximum shear force will occur when wind is taken at 0 degrees.

The shear force due to wind on superstructure is taken from Table 7-1:

$$WS = 30.69K$$

The shear force due to wind on live load is taken from Table 7-2:

$$WL = 6.00K$$

The controlling shear force is either from Strength III or Strength V:

Factored shear force per bearing for Strength III:

$$\gamma_{WS} = 1.40$$

STable 3.4.1-1

$$\gamma_{WL} = 0.00$$

STable 3.4.1-1

$$V_{\text{windstrIII}} = \frac{(\gamma_{WS} \cdot WS + \gamma_{WL} \cdot WL)}{5}$$

$$V_{\text{windstrIII}} = 8.59 \text{ K}$$

Factored shear force per bearing for Strength V:

$$\gamma_{WS} = 0.40$$

STable 3.4.1-1

$$\gamma_{WL} = 1.00$$

STable 3.4.1-1

$$V_{\text{windstrV}} = \frac{(\gamma_{WS} \cdot WS + \gamma_{WL} \cdot WL)}{5}$$

$$V_{\text{windstrV}} = 3.66 \text{ K}$$

Use: $V_{\text{max}} = \max(V_{\text{windstrIII}}, V_{\text{windstrV}})$

$$V_{\text{max}} = 8.59 \text{ K}$$

$$\frac{1}{5} \cdot P_{\text{sd}} = 13.56 \text{ K}$$

Since the maximum shear force at the strength limit state does not exceed one-fifth of the minimum vertical force due to permanent dead loads, the pad does not need to be secured against horizontal movement.

Design Step 6.13 - Design Anchorage for Fixed Bearings

The abutment bearings are expansion in the longitudinal direction but fixed in the transverse direction. Therefore, the bearings must be restrained in the transverse direction. Based on Design Step 6.12, the expansion bearing pad does not need to be secured against horizontal movement. However, based on S3.10.9.2, the horizontal connection force in the restrained direction cannot be less than 0.1 times the vertical reaction due to the tributary permanent load and the tributary live loads assumed to exist during an earthquake. In addition, since all abutment bearings are restrained in the transverse direction, the tributary permanent load can be taken as the reaction at the bearing. Also, γ_{EQ} is assumed to be zero. Therefore, no tributary live loads will be considered. This transverse load will be used to design the bearing anchor bolts for this design example.

S14.8.3.1

S3.10.9.2

C3.4.1

For the controlling girder (interior):

$$DL_{serv} = 78.4K$$

The maximum transverse horizontal earthquake load per bearing is then:

$$H_{EQ} = 0.1 \cdot DL_{serv}$$

$$H_{EQ} = 7.84K$$

The factored shear resistance of the anchor bolts per bearing is then:

S14.8.3.1

S6.13.2.7

Assume two 5/8" diameter A 307 bolts with a minimum tensile strength of 60 ksi:

S6.4.3

$$R_n = 0.48 \cdot A_b \cdot F_{ub} \cdot N_s \quad \text{for threads excluded from shear plane}$$

S6.13.2.7

$$\phi_s = 0.65 \quad \text{resistance factor for A 307 bolts in shear}$$

S6.5.4.2

$$A_b = \frac{\pi \cdot (0.625 \text{ in})^2}{4}$$

$$A_b = 0.31 \text{ in}^2$$

$$F_{ub} = 60\text{ksi}$$

$$N_s = 2 \quad (\text{number of bolts})$$

$$R_n = 0.48 \cdot A_b \cdot F_{ub} \cdot N_s \quad R_n = 17.67\text{K}$$

$$R_r = \phi_s \cdot R_n \quad R_r = 11.49\text{K}$$

$$R_r \geq H_{EQ} \quad \text{OK}$$

Once the anchor bolt quantity and size are determined, the anchor bolt length must be computed. As an approximation, the bearing stress may be assumed to vary linearly from zero at the end of the embedded length to its maximum value at the top surface of the concrete. The bearing resistance of the concrete is based on S5.7.5.

S14.8.3.1

C14.8.3.1

$$\phi_b \cdot P_n = \phi_b \cdot 0.85 \cdot f_c \cdot A_1 \cdot m^2$$

S5.7.5

$$\text{Stress}_{\text{brg}} = \frac{\phi_b \cdot P_n}{A_1}$$

$$\text{Stress}_{\text{brg}} = \phi_b \cdot 0.85 \cdot f_c \cdot m^2$$

Assume: $m = 0.75$ (conservative assumption)

$\phi_b = 0.70$ for bearing on concrete

S5.5.4.2.1

$$\text{Stress}_{\text{brg}} = \phi_b \cdot 0.85 \cdot (4\text{ksi}) \cdot m$$

$$\text{Stress}_{\text{brg}} = 1.78\text{ksi}$$

The total transverse horizontal load is:

$$H_{EQ} = 7.84\text{K}$$

The transverse load per anchor bolt is then:

$$P_{1\text{bolt}} = \frac{H_{EQ}}{2}$$

$$P_{1\text{bolt}} = 3.92\text{K}$$

Using the bearing stress approximation from above, the required anchor bolt area resisting the transverse horizontal load can be calculated.

$$A_1 = \frac{P_{1\text{bolt}}}{\left(\frac{\text{Stress}_{\text{brg}} + 0}{2}\right)}$$

$$A_1 = 4.39 \text{ in}^2$$

A_1 is the product of the anchor bolt diameter and the length the anchor bolt is embedded into the concrete pedestal/beam seat. Since we know the anchor bolt diameter, we can now solve for the required embedment length.

$$L_{\text{embed}} = \frac{A_1}{0.625 \text{ in}}$$

$$L_{\text{embed}} = 7.03 \text{ in}$$

Individual states and agencies have their own minimum anchor bolt embedment lengths. For this design example, a minimum of 12 inches will be used.

Use: $L_{\text{embed}} = 12.0 \text{ in}$

Design Step 6.14 - Draw Schematic of Final Bearing Design

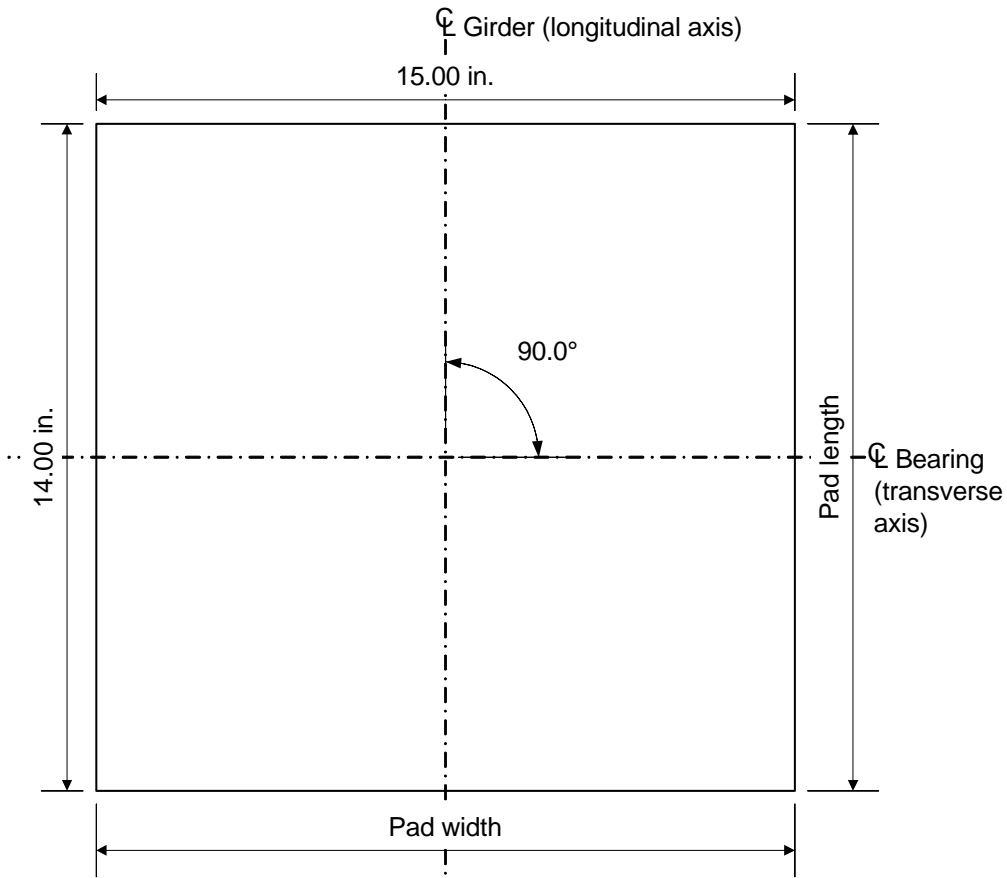

Figure 6-1 Bearing Pad Plan View

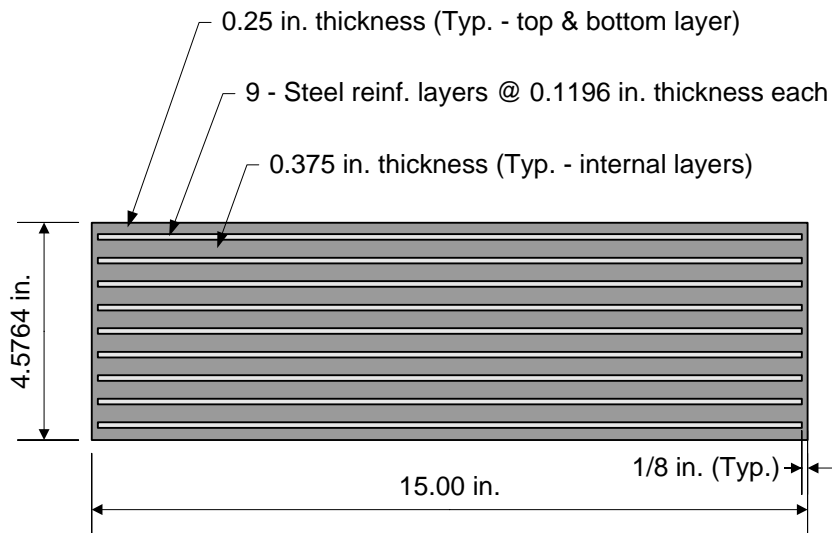

Figure 6-2 Bearing Pad Elevation View

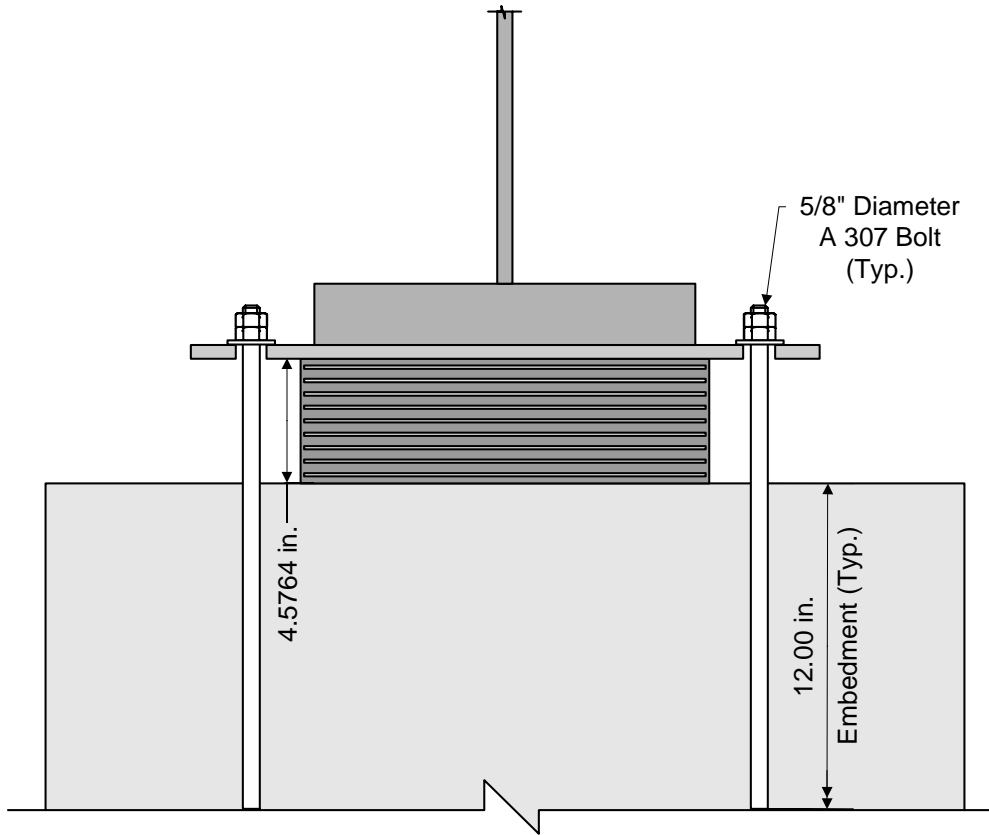

Figure 6-3 Anchor Bolt Embedment

Abutment and Wingwall Design Example Design Step 7

Table of Contents

	<u>Page</u>
Design Step 7.1 - Obtain Design Criteria	2
Design Step 7.2 - Select Optimum Abutment Type	5
Design Step 7.3 - Select Preliminary Abutment Dimensions	5
Design Step 7.4 - Compute Dead Load Effects	6
Design Step 7.5 - Compute Live Load Effects	8
Design Step 7.6 - Compute Other Load Effects	10
Design Step 7.7 - Analyze and Combine Force Effects	27
Design Step 7.8 - Check Stability and Safety Requirements	54
Design Step 7.9 - Design Abutment Backwall	54
Design Step 7.10 - Design Abutment Stem	63
Design Step 7.11 - Design Abutment Footing	71
Design Step 7.12 - Draw Schematic of Final Abutment Design	97
Design Step 7.2 - Select Optimum Wingwall Type	98
Design Step 7.3 - Select Preliminary Wingwall Dimensions	98
Design Step 7.4 - Compute Dead Load Effects	99
Design Step 7.5 - Compute Live Load Effects	101
Design Step 7.6 - Compute Other Load Effects	101
Design Step 7.7 - Analyze and Combine Force Effects	104
Design Step 7.9 - Design Wingwall Stem	111
Design Step 7.12 - Draw Schematic of Final Wingwall Design	119

Design Step 7.1 - Obtain Design Criteria

This abutment and wingwall design example is based on *AASHTO LRFD Bridge Design Specifications* (through 2002 interims). The design methods presented throughout the example are meant to be the most widely used in general bridge engineering practice. The example covers the abutment backwall, stem, and footing design, using pile loads from Design Step P, Pile Foundation Design Example. The wingwall design focuses on the wingwall stem only. All applicable loads that apply to the abutment and wingwall are either taken from design software or calculated herein.

The wingwall design utilizes the same flowchart as the abutment. Design Step 7.1 is shared by both the abutment and wingwall. After Design Step 7.1, Design Steps 7.2 through 7.12 are for the abutment. For the wingwall, any Design Steps from 7.2 through 7.12 that apply to the wingwall follow at the end of the abutment design steps. For example, there are two Design Steps 7.2 - one for the abutment and one for the wingwall (after Design Step 7.12 of the abutment).

Refer to Design Step 1 for introductory information about this design example. Additional information is presented about the design assumptions, methodology, and criteria for the entire bridge, including the abutments and wingwalls.

In order to begin the design, the abutment and wingwall properties as well as information about the superstructure that the abutment supports is required.

The following units are defined for use in this design example:

$$K = 1000\text{lb} \quad \text{kcf} = \frac{K}{\text{ft}^3} \quad \text{ksi} = \frac{K}{\text{in}^2} \quad \text{kst} = \frac{K}{\text{ft}^2} \quad \text{klf} = \frac{K}{\text{ft}}$$

It should be noted that the superstructure loads and plate girder dimensions used in this design step are based on the first trial of the girder design.

Material properties:Concrete density: $W_c = 0.150\text{kcf}$

STable 3.5.1-1

Concrete 28-day
compressive strength: $f'_c = 4.0\text{ksi}$

S5.4.2.1

SC5.4.2.1

STable C5.4.2.1-1

Reinforcement
strength: $f_y = 60\text{ksi}$

S5.4.3

Reinforcing steel cover requirements:Backwall back cover: $\text{Cover}_b = 2.5\text{in}$

STable 5.12.3-1

Stem back cover: $\text{Cover}_s = 2.5\text{in}$

STable 5.12.3-1

Footing top cover: $\text{Cover}_{ft} = 2.0\text{in}$

STable 5.12.3-1

Footing bottom cover: $\text{Cover}_{fb} = 3.0\text{in}$

STable 5.12.3-1

Backwall back cover - Assuming that the backwall will be subject to deicing salts, the cover is set at 2.5 inches.

STable 5.12.3-1

Stem cover - The stem cover is set at 2.5 inches. This will allow the vertical flexure reinforcement in the stem to be lapped with the vertical back face reinforcement in the backwall. Also, it is assumed that the stem may be exposed to deicing salts due to the abutment having an expansion joint.

STable 5.12.3-1

Footing top cover - The footing top cover is set at 2.0 inches.

STable 5.12.3-1

Footing bottom cover - Since the footing bottom is cast directly against the earth, the footing bottom cover is set at 3.0 inches.

STable 5.12.3-1

Relevant superstructure data:

Girder spacing:	$S = 9.75\text{ft}$
Number of girders:	$N = 5$
Span length:	$L_{\text{span}} = 120\text{ft}$
Parapet height:	$H_{\text{par}} = 3.5\text{ft}$
Parapet weight (each):	$W_{\text{par}} = 0.53 \frac{\text{K}}{\text{ft}}$
Out-to-out deck width:	$W_{\text{deck}} = 46.875\text{ft}$

Superstructure data - The above superstructure information was taken from Design Steps 1 and 2.

Abutment and wingwall height

S2.3.3.2

Abutment stem height:	$h_{\text{stem}} = 22\text{ft}$	
Wingwall stem design height:	$h_{\text{wwstem}} = 20.75\text{ft}$	use height at 3/4 point

Abutment and wingwall length

S11.6.1.4

Abutment length:	$L_{\text{abut}} = 46.875\text{ft}$
Wingwall length:	$L_{\text{wing}} = 20.5\text{ft}$

Design Step 7.2 - Select Optimum Abutment Type

Selecting the optimal abutment type depends on the site conditions, cost considerations, superstructure geometry, and aesthetics. The most common abutment types include cantilever, gravity, counterfort, mechanically-stabilized earth, stub, semi-stub or shelf, open or spill through, and integral or semi-integral. For this design example, a full-depth reinforced concrete cantilever abutment was chosen because it is the most economical for the site conditions. For a concrete cantilever abutment, the overturning forces are balanced by the vertical earth load on the abutment heel. Concrete cantilever abutments are the typical abutment type used for most bridge designs and is considered optimal for this abutment design example.

S11.2

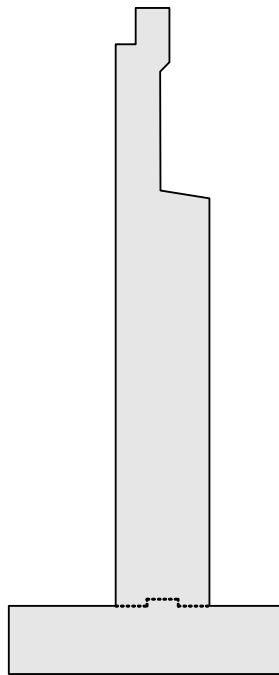

Figure 7-1 Full-Depth Reinforced Concrete Cantilever Abutment

Design Step 7.3 - Select Preliminary Abutment Dimensions

Since AASHTO does not have standards for the abutment backwall, stem, or footing maximum or minimum dimensions, the designer should base the preliminary abutment dimensions on state specific standards, previous designs, and past experience. The abutment stem, however, must be wide enough to allow for the minimum displacement requirements. The minimum support length is calculated in Design Step 7.6.

S4.7.4.4

The following figure shows the preliminary dimensions for this abutment design example.

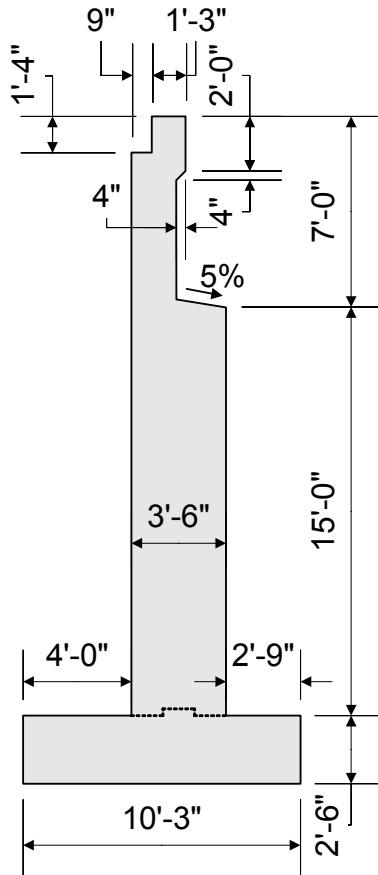

Figure 7-2 Preliminary Abutment Dimensions

For sealed expansion joints, slope the top surface of the abutment (excluding bearing seats) a minimum of 5% towards the edge.

S2.5.2.1.2

Design Step 7.4 - Compute Dead Load Effects

Once the preliminary abutment dimensions are selected, the corresponding dead loads can be computed. Along with the abutment dead loads, the superstructure dead loads must be computed. The superstructure dead loads acting on the abutment will be given based on the superstructure output from the software used to design the superstructure. The dead loads are calculated on a per foot basis. Also, the dead loads are calculated assuming the beam seat is level.

S3.5.1

The superstructure dead load reactions per bearing were obtained from trial one of the steel girder design and are as follows.

Fascia girder:

$$R_{DCfascia} = 69.25K \quad R_{DWfascia} = 11.24K$$

Interior girder:

$$R_{DCinterior} = 73.51K \quad R_{DWinterior} = 11.24K$$

As previously stated, the superstructure dead load reactions must be converted into a load applied to a one-foot strip of abutment. This is accomplished by adding the two fascia girder dead load reactions with the three interior girder dead load reactions and then dividing by the abutment length.

$$R_{DCtot} = \frac{(2 \cdot R_{DCfascia}) + (3 \cdot R_{DCinterior})}{L_{abut}}$$

$$R_{DCtot} = 7.66 \frac{K}{ft}$$

$$R_{DWtot} = \frac{(2 \cdot R_{DWfascia}) + (3 \cdot R_{DWinterior})}{L_{abut}}$$

$$R_{DWtot} = 1.20 \frac{K}{ft}$$

Backwall dead load:

$$DL_{bw} = \left[(1.25ft \cdot 1.33ft) + (2.0ft \cdot 0.67ft) \dots \right] \cdot W_c$$

$$+ \left[\left(\frac{2ft + 1.67ft}{2} \right) \cdot 0.33ft \right] + (4.67ft \cdot 1.67ft) \right]$$

$$DL_{bw} = 1.71 \frac{K}{ft}$$

Stem dead load:

$$DL_{stem} = 15ft \cdot 3.5ft \cdot W_c$$

$$DL_{stem} = 7.88 \frac{K}{ft}$$

Footing dead load:

$$DL_{ftg} = 10.25\text{ft} \cdot 2.5\text{ft} \cdot W_c$$

$$DL_{ftg} = 3.84 \frac{\text{K}}{\text{ft}}$$

Earth dead load:

$$\gamma_s = 0.120\text{kcf} \text{ use average of loose and compacted gravel}$$

$$DL_{earth} = 22\text{ft} \cdot 4\text{ft} \cdot \gamma_s$$

$$DL_{earth} = 10.56 \frac{\text{K}}{\text{ft}}$$

STable 3.5.1-1

Design Step 7.5 - Compute Live Load Effects

The live load effects were also obtained from trial one of the girder design. The reactions for one girder are given as unfactored, without impact, and without distribution factors. The given reactions are converted into one loaded lane and then converted into a per foot load.

Dynamic load allowance, IM	$IM = 0.33$
----------------------------	-------------

STable 3.6.2.1-1

Multiple presence factor, m (1 lane)	$m_1 = 1.20$
--------------------------------------	--------------

STable 3.6.1.1.2-1

Multiple presence factor, m (2 lanes)	$m_2 = 1.00$
---------------------------------------	--------------

STable 3.6.1.1.2-1

Multiple presence factor, m (3 lanes)	$m_3 = 0.85$
---------------------------------------	--------------

STable 3.6.1.1.2-1

For this design example, the backwall live load is computed by placing three design truck axles along the abutment and calculating the load on a per foot basis including impact and the multiple presence factor. This load is applied to the entire length of abutment backwall and is assumed to act at the front top corner (bridge side) of the backwall. This load is not applied, however, when designing the abutment stem or footing.

$$R_{LLbw} = \frac{[6 \cdot (16 \cdot K) \cdot (1 + IM) + 3 \cdot (0.64 \cdot \text{klf}) \cdot (2.0 \cdot \text{ft})]}{L_{abut}}$$

$$R_{LLbw} = 2.81 \frac{\text{K}}{\text{ft}}$$

The following loads are obtained from girder design software output for one lane loaded and they are applied at the beam seat or top of abutment stem for the stem design.

$$V_{vehmax} = 64.90K \quad \text{Based on first trial of girder design}$$

$$V_{lanemax} = 33.25K \quad \text{Based on first trial of girder design}$$

$$V_{vehmin} = -7.28K \quad \text{Based on first trial of girder design}$$

$$V_{lanemin} = -5.15K \quad \text{Based on first trial of girder design}$$

The controlling maximum and minimum live loads are for three lanes loaded. The loads are multiplied by dynamic load allowance and the multiple presence factor.

Maximum unfactored live load used for abutment stem design:

$$r_{LLmax} = V_{vehmax} \cdot (1 + IM) + V_{lanemax}$$

$$r_{LLmax} = 119.57K \quad \text{for one lane}$$

$$R_{LLmax} = \frac{3 \cdot m_3 \cdot r_{LLmax}}{L_{abut}}$$

$$R_{LLmax} = 6.50 \frac{K}{ft}$$

Minimum unfactored live load representing uplift used for abutment stem design:

$$r_{LLmin} = V_{vehmin} \cdot (1 + IM) + V_{lanemin}$$

$$r_{LLmin} = -14.83K \quad \text{for one lane}$$

$$R_{LLmin} = \frac{3 \cdot m_3 \cdot r_{LLmin}}{L_{abut}}$$

$$R_{LLmin} = -0.81 \frac{K}{ft}$$

The following loads are applied at the beam seat or top of abutment stem for the footing design. The loads do not include dynamic load allowance, but do include the multiple presence factor.

S3.6.2.1

Maximum unfactored live load used for abutment footing design:

$$r_{LLmax1} = V_{vehmax} + V_{lanemax}$$

$$r_{LLmax1} = 98.15 \text{ K} \quad \text{for one lane loaded}$$

$$R_{LLmax1} = \frac{3 \cdot m_3 \cdot r_{LLmax1}}{L_{abut}}$$

$$R_{LLmax1} = 5.34 \frac{\text{K}}{\text{ft}}$$

Minimum unfactored vehicle load used for abutment footing design:

$$r_{LLmin1} = V_{vehmin} + V_{lanemin}$$

$$r_{LLmin1} = -12.43 \text{ K} \quad \text{for one lane loaded}$$

$$R_{LLmin1} = \frac{3 \cdot m_3 \cdot r_{LLmin1}}{L_{abut}}$$

$$R_{LLmin1} = -0.68 \frac{\text{K}}{\text{ft}}$$

Design Step 7.6 - Compute Other Load Effects

Other load effects that need to be computed include braking force, wind loads, earthquake loads, earth pressure, live load surcharge, and temperature loads.

Braking Force

Since the abutment has expansion bearings, the braking force does not apply at the abutment. The entire braking force is resisted by the fixed bearings located at the pier. Braking force calculations are provided in Design Step 8.

Wind Load on Superstructure

S3.8.1.2

When calculating the superstructure wind load, the total depth from the top of the barrier to the bottom of the girder is required. Included in this depth is any haunch and/or depth due to the bridge deck cross slope. Once the total depth is known, the wind area can be calculated and the wind pressure can be applied.

The total depth is:

$$h_{\text{par}} = 42\text{in}$$

$$t_{\text{deck}} = 9\text{in} \quad \text{overhang deck thickness}$$

$$t_{\text{cslope}} = 0\text{in} \quad \text{assume no cross slope for design}$$

$$t_{\text{topflg}} = 0\text{in} \quad \text{top flange embedded in haunch; therefore, ignore top flange thickness}$$

$$d_{\text{web}} = 66\text{in} \quad \text{based on first trial of girder design}$$

$$t_{\text{botflg}} = 2.25\text{in} \quad \text{use maximum bottom flange thickness, based on first trial of girder design}$$

$$t_{\text{haunch}} = 3.5\text{in}$$

$$D_{\text{tot}} = \frac{h_{\text{par}} + t_{\text{deck}} + t_{\text{cslope}} + t_{\text{topflg}} + d_{\text{web}} + t_{\text{botflg}} + t_{\text{haunch}}}{12 \frac{\text{in}}{\text{ft}}}$$

$$D_{\text{tot}} = 10.23\text{ft}$$

The wind load on the abutment from the superstructure will be from one-half of one span length or:

$$L_{\text{wind}} = 60\text{ft}$$

The wind area is:

$$A_{\text{wsuper}} = D_{\text{tot}} \cdot L_{\text{wind}}$$

$$A_{\text{wsuper}} = 613.75\text{ft}^2$$

Since the abutment is less than 30 feet in height, the design wind velocity, V_{DZ} , does not have to be adjusted and is equal to the base wind velocity.

$$V_{\text{B}} = 100 \text{ mph}$$

$$V_{\text{DZ}} = V_{\text{B}}$$

From this, the design wind pressure is equal to the base wind pressure:

$$P_{\text{D}} = P_{\text{B}} \cdot \left(\frac{V_{\text{DZ}}}{V_{\text{B}}} \right)^2 \quad \text{or} \quad P_{\text{D}} = P_{\text{B}} \cdot \left(\frac{100\text{mph}}{100\text{mph}} \right)^2$$

$$P_{\text{D}} = P_{\text{B}}$$

Also, the total wind loading on girders must be greater than or equal to 0.30 klf:

$$\text{Wind}_{\text{total}} = 0.050\text{ksf} \cdot D_{\text{tot}}$$

$$\text{Wind}_{\text{total}} = 0.51 \frac{\text{K}}{\text{ft}}, \text{ which is greater than } 0.30 \text{ klf}$$

The wind load from the superstructure acting on the abutment depends on the attack angle of the wind. Two wind load calculations are provided for two different wind attack angles. All wind loads are tabulated in Table 7-1 for the various attack angles. The attack angle is measured from a line perpendicular to the girder longitudinal axis. The wind pressure can be applied to either superstructure face. The base wind pressures for the superstructure for various attack angles are given in *S*Table 3.8.1.2.2-1. Since the abutment has expansion bearings, the longitudinal component of the wind load on superstructure will not be resisted by the abutment and is not required to be calculated. The fixed pier will resist the longitudinal wind component.

S3.8.1.1

S3.8.1.2.1

S3.8.1.2.1

S3.8.1.2.2

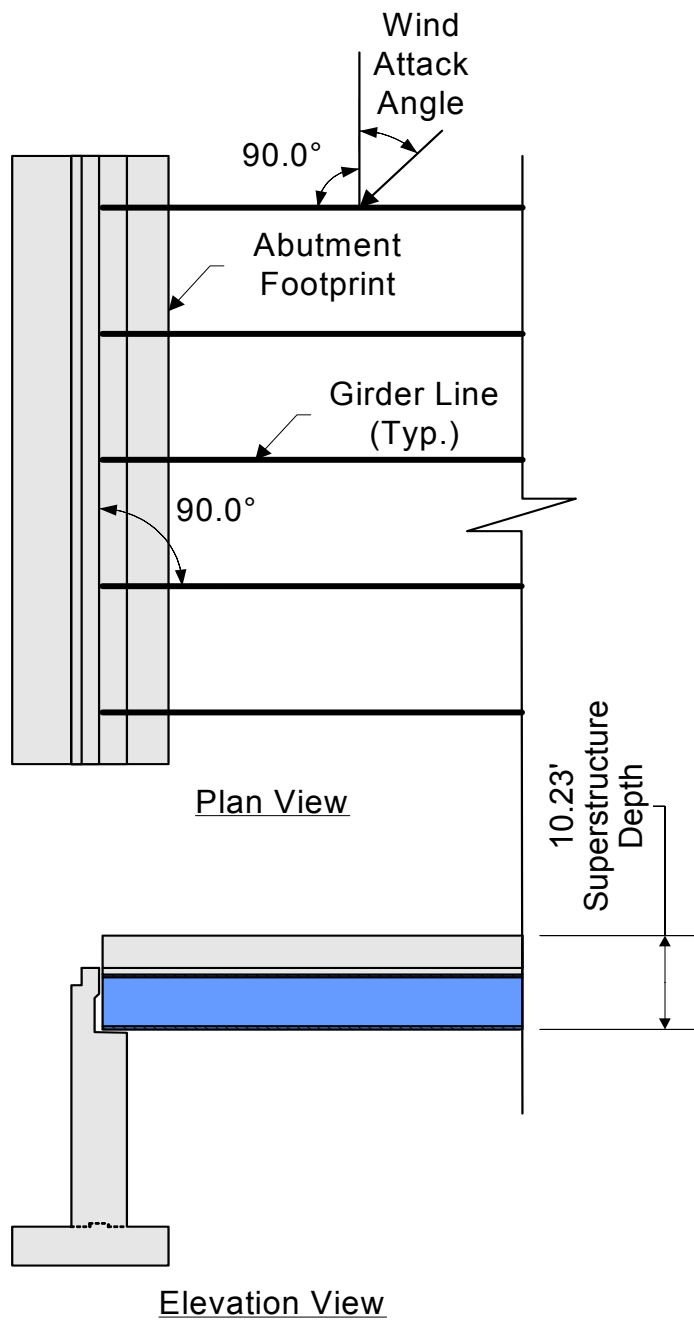

Figure 7-3 Application of Superstructure Wind Load on Abutment

For a wind attack angle of 0 degrees, the superstructure wind loads acting on the abutment are:

$$WS_{\text{supertrans}0} = A_{\text{wsuper}} \cdot 0.050 \text{ksf}$$

$$WS_{\text{supertrans}0} = 30.69 \text{K}$$

$$WS_{\text{superlong}0} = A_{\text{wsuper}} \cdot 0.000 \text{ksf}$$

$$WS_{\text{superlong}0} = 0.00 \text{K} \quad \text{not applicable due to expansion bearings at abutment}$$

For a wind attack angle of 60 degrees, the superstructure wind loads acting on the abutment are:

$$WS_{\text{supertrans}60} = A_{\text{wsuper}} \cdot 0.017 \text{ksf}$$

$$WS_{\text{supertrans}60} = 10.43 \text{K}$$

$$WS_{\text{superlong}60} = A_{\text{wsuper}} \cdot 0.019 \text{ksf}$$

$$WS_{\text{superlong}60} = 11.66 \text{K} \quad \text{not applicable due to expansion bearings at abutment}$$

STable 3.8.1.2.2-1

STable 3.8.1.2.2-1

Abutment Design Wind Loads from Superstructure		
Wind Attack Angle	Bridge Transverse Axis	Bridge * Longitudinal Axis
Degrees	Kips	Kips
0	30.69	0.00
15	27.01	3.68
30	25.16	7.37
45	20.25	9.82
60	10.43	11.66

* Provided but not applicable due to expansion bearings at abutment.

Table 7-1 Abutment Design Wind Loads from Superstructure for Various Wind Attack Angles

Wind Load on Abutment (Substructure)

The wind loads acting on the exposed portion of the abutment front and end elevations are calculated from a base wind pressure of 0.040 ksf. These loads act simultaneously with the superstructure wind loads.

S3.8.1.2.3

Since all wind loads acting on the abutment front face decrease the maximum longitudinal moment, all abutment front face wind loads will be conservatively ignored.

The abutment exposed end elevation wind area is:

$$A_{wsubend} = (3.5ft) \cdot (22ft)$$

$$A_{wsubend} = 77.00 \text{ ft}^2$$

Two wind load calculations for the abutment end elevation are shown below for a wind attack angle of zero and sixty degrees. All other wind attack angles do not control and are not shown.

For a wind attack angle of 0 degrees, the wind loads acting on the abutment end elevation are:

$$WS_{subtransend0} = A_{wsubend} \cdot (0.040 \cdot \text{ksf} \cdot \cos(0 \cdot \text{deg}))$$

$$WS_{subtransend0} = 3.08 \text{ K}$$

$$WS_{sublongend0} = A_{wsubend} \cdot (0.040 \text{ksf} \cdot \sin(0 \text{deg}))$$

$$WS_{sublongend0} = 0.00 \text{ K}$$

For a wind attack angle of 60 degrees, the wind loads acting on the abutment end elevation are:

$$WS_{\text{subtransend60}} = A_{\text{wsubend}} \cdot (0.040 \cdot \text{ksf} \cdot \cos(60 \cdot \text{deg}))$$

$$WS_{\text{subtransend60}} = 1.54 \text{ K}$$

$$WS_{\text{sublongend60}} = A_{\text{wsubend}} \cdot (0.040 \text{ksf} \cdot \sin(60 \text{deg}))$$

$$WS_{\text{sublongend60}} = 2.67 \text{ K}$$

Wind Load on Vehicles

The wind load applied to vehicles is given as 0.10 klf acting normal to and 6.0 feet above the roadway. For wind loads that are not normal to the roadway, the Specifications give a table of wind components on live load. For normal and skewed wind pressures on vehicles, the wind load is calculated by multiplying the wind component by the length of structure over which it acts. An example calculation is provided and Table 7-2 shows all the vehicle wind loads for the various wind attack angles. As with the superstructure wind load, the longitudinal wind load on vehicles is not resisted by the abutment due to expansion bearings. The calculation for longitudinal vehicular wind loads is not required but is provided in this design example.

For a wind attack angle of 0 degrees, the vehicular wind loads are:

$$L_{\text{wind}} = 60 \text{ ft}$$

$$WL_{\text{trans0}} = L_{\text{wind}} \cdot (0.1 \cdot \text{klf})$$

$$WL_{\text{trans0}} = 6.00 \text{ K}$$

$$WL_{\text{long0}} = L_{\text{wind}} \cdot (0.000 \text{ klf})$$

$$WL_{\text{long0}} = 0.00 \text{ K} \quad \text{not applicable due to expansion bearings at abutment}$$

S3.8.1.3

STable 3.8.1.3-1

STable 3.8.1.3-1

Design Vehicular Wind Loads		
Wind Attack Angle	Bridge Transverse Axis	Bridge * Longitudinal Axis
Degrees	Kips	Kips
0	6.00	0.00
15	5.28	0.72
30	4.92	1.44
45	3.96	1.92
60	2.04	2.28

* Provided but not applicable due to expansion bearings at abutment.

Table 7-2 Design Vehicular Wind Loads for Various Wind Attack Angles

Vertical Wind Load

The vertical wind load is calculated by multiplying a 0.020 ksf vertical wind pressure by the out-to-out bridge deck width. It is applied to the windward quarter-point of the deck only for limit states that do not include wind on live load. Also, the wind attack angle must be zero degrees for the vertical wind load to apply.

$$W_{\text{vert}} = 0.020 \text{ksf} \cdot W_{\text{deck}} \quad W_{\text{vert}} = 0.94 \frac{\text{K}}{\text{ft}} \text{ acts vertically upward}$$

Earthquake Load

This design example assumes that the structure is located in Seismic Zone I with an acceleration coefficient of 0.02 and a Soil Type I. For Seismic Zone I, no seismic analysis is required except designing for the minimum connection force between the superstructure and substructure and the minimum bridge seat requirements.

The horizontal connection force in the restrained direction is 0.1 times the vertical reaction due to the tributary permanent load and the tributary live loads assumed to exist during an earthquake. In addition, since all abutment bearings are restrained in the transverse direction, the tributary permanent load can be taken as the reaction at the bearing. Also, γ_{EQ} is assumed to be zero. Therefore, no tributary live loads will be considered. This transverse load is calculate and used to design the bearing anchor bolts and is mentioned here for reference only. Refer to Design Step 6 for bearing and anchor bolt design and the calculation of the horizontal connection force.

S3.8.2

S3.10

S4.7.4.1

S3.10.9

S4.7.4.4

S3.10.9.2

SC3.10.9.2

S3.4.1

From S4.7.4.3, for Seismic Zone I, no seismic analysis is required. Therefore, the minimum displacement requirement must be obtained from a percentage of the empirical seat width. The percentage of the minimum support length, N, is based on Seismic Zone I, an acceleration coefficient of 0.02, and Soil Type I. From the above information, 50 percent or greater of the minimum support length is required.

S4.7.4.4

STable 4.7.4.4-1

Minimum support length required:

$$N = (8 + 0.02L + 0.08H) \cdot (1 + 0.000125S^2)$$

S4.7.4.4

$$L = 240 \text{ ft} \quad H = 22 \text{ ft} \quad S = 0 \text{ deg}$$

$$N = (8 + 0.02L + 0.08H) \cdot (1 + 0.000125S^2)$$

$$N = 14.56 \text{ in} \quad \text{Use} \quad N = 15 \text{ in}$$

Since the selected preliminary abutment dimensions in Design Step 7.3 leave 18 inches as a support length, this design example will use 100 percent of the minimum support length.

STable 4.7.4.4-1

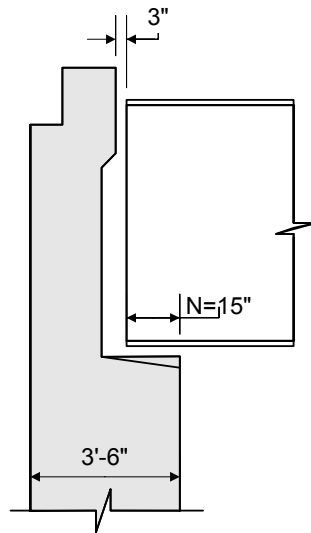

Figure 7-4 Minimum Support Length Required

Earth Loads

S3.11

The earth loads that need to be investigated for this design example include loads due to basic lateral earth pressure, loads due to uniform surcharge, and live load surcharge loads.

S3.11.5

S3.11.6

The water table is considered to be below the bottom of footing for this design example. Therefore, the effect of hydrostatic water pressure does not need to be added to the earth pressure. Hydrostatic water pressure should be avoided if possible in all abutment and retaining wall design cases through the design of an appropriate drainage system. Some ways that can reduce or eliminate hydrostatic water pressure include the use of pipe drains, gravel drains, perforated drains, geosynthetic drains, or backfilling with crushed rock. It should be noted that the use of weep holes, or drains at the wall face, do not assure fully drained conditions.

S3.11.3

S11.6.6

Loads due to basic lateral earth pressure:

S3.11.5

To obtain the lateral loads due to basic earth pressure, the earth pressure (p) must first be calculated from the following equation.

S3.11.5.1

$$p = k_a \cdot \gamma_s \cdot z$$

Bottom of backwall lateral earth load:

$$k_a = 0.3 \quad \text{obtained from geotechnical information}$$

$$\gamma_s = 0.120 \text{ kcf} \quad \text{use average of loose and compacted gravel}$$

STable 3.5.1-1

$$z = 7 \text{ ft} \quad \text{backwall height}$$

$$p = k_a \cdot \gamma_s \cdot z$$

$$p = 0.25 \text{ ksf}$$

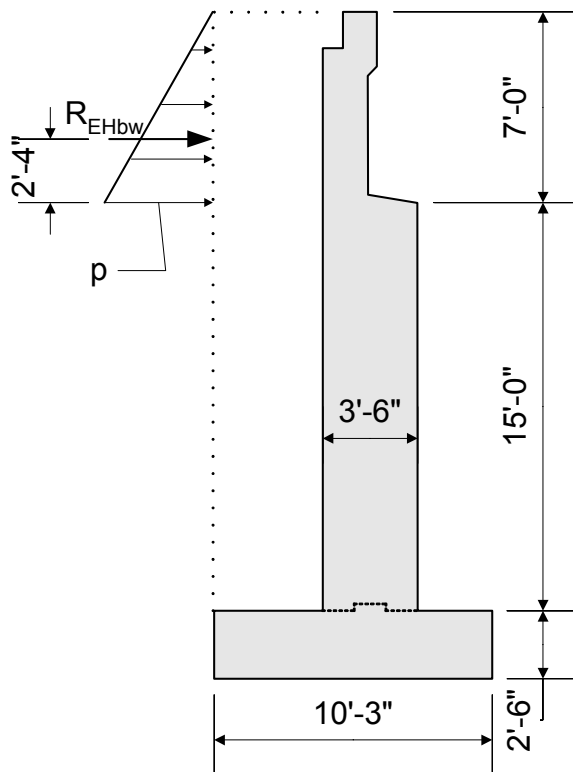

Figure 7-5 Backwall Design Earth Pressure

Once the lateral earth pressure is calculated, the lateral load due to the earth pressure can be calculated. This load acts at a distance of $H/3$ from the bottom of the section being investigated.

$$h_{bkwl} = 7\text{ft}$$

$$R_{EHbw} = \left(\frac{1}{2}\right) \cdot p \cdot h_{bkwl}$$

$$R_{EHbw} = 0.88 \frac{\text{K}}{\text{ft}}$$

S3.11.5.1
SC3.11.5.1

Bottom of abutment stem lateral earth load:

$k_a = 0.3$ obtained from geotechnical information

$\gamma_s = 0.120\text{kcf}$ use average of loose and compacted gravel

$z = 22\text{ft}$ height used for maximum moment at bottom of abutment stem

$$p = k_a \cdot \gamma_s \cdot z$$

$$p = 0.79\text{kSF}$$

STable 3.5.1-1

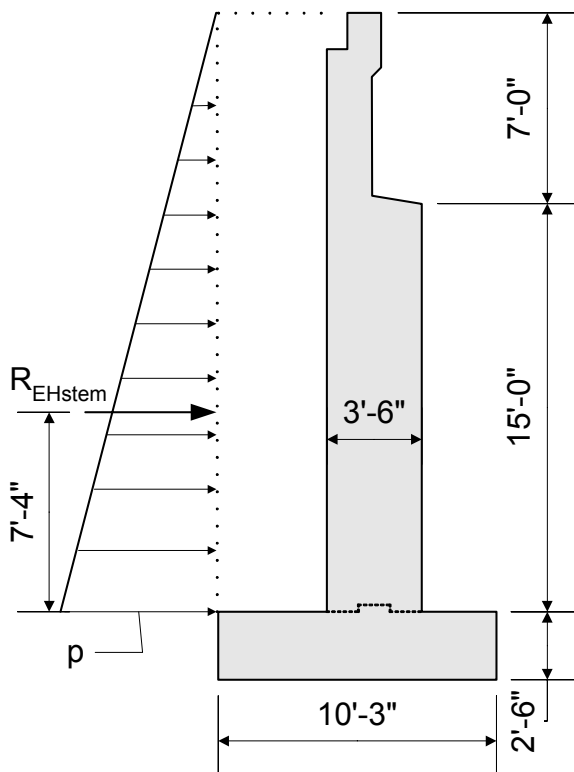

Figure 7-6 Abutment Stem Design Earth Pressure

Once the lateral earth pressure is calculated, the lateral load due to the earth pressure can be calculated. This load acts at a distance of H/3 from the bottom of the section being investigated.

$$R_{EHstem} = \left(\frac{1}{2}\right) \cdot p \cdot h_{stem}$$

$$R_{EHstem} = 8.71 \frac{\text{K}}{\text{ft}}$$

S3.11.5.1

SC3.11.5.1

Bottom of footing lateral earth load:

- $k_a = 0.3$ obtained from geotechnical information
- $\gamma_s = 0.120\text{kcf}$ use average of loose and compacted gravel
- $z = 24.5\text{ft}$ height from top of backwall to bottom of footing
- $p = k_a \cdot \gamma_s \cdot z$
- $p = 0.88\text{ksf}$

STable 3.5.1-1

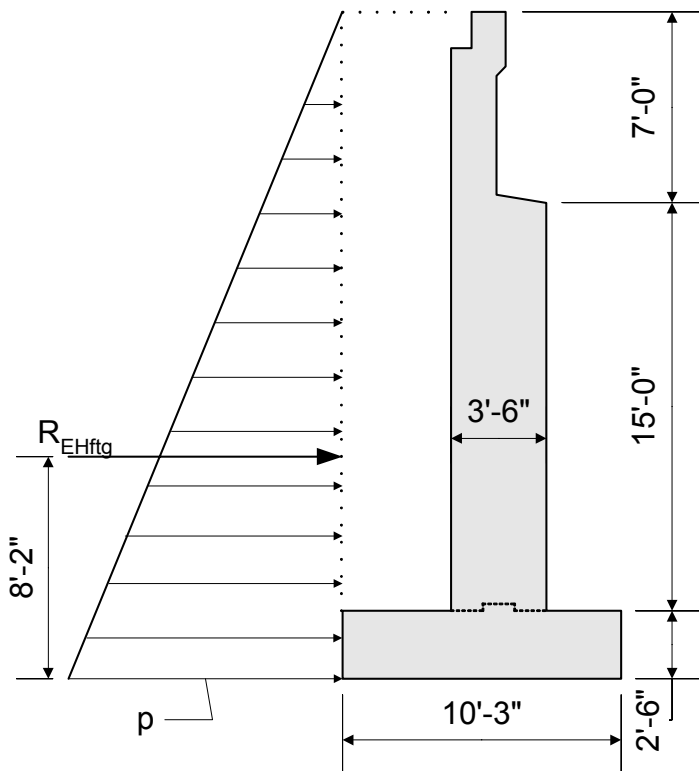

Figure 7-7 Bottom of Footing Design Earth Load

Once the lateral earth pressure is calculated, the lateral load due to the earth pressure can be calculated. This load acts at a distance of $H/3$ from the bottom of the section being investigated.

$$t_{ftg} = 2.5\text{ft}$$

$$R_{EHftg} = \left(\frac{1}{2}\right) \cdot p \cdot (h_{stem} + t_{ftg})$$

$$R_{EHftg} = 10.80 \frac{\text{K}}{\text{ft}}$$

S3.11.5.1

SC3.11.5.1

Loads due to uniform surcharge:

Since an approach slab and roadway will cover the abutment backfill material, no uniform surcharge load will be applied.

S3.11.6.1

Loads due to live load surcharge:

Loads due to live load surcharge must be applied when a vehicular live load acts on the backfill surface behind the back face within one-half the wall height. The horizontal pressure increase due to live load surcharge is estimated based on the following equation:

S3.11.6.4

$$\Delta_p = k \cdot \gamma_s \cdot h_{eq}$$

Bottom of backwall live load surcharge load:

$$k = k_a$$

$$\gamma_s = 0.120 \text{ kcf} \quad \text{use average of loose and compacted gravel}$$

STable 3.5.1-1

$$h_{eq} = 3.6 \text{ ft} \quad \text{equivalent height of soil for vehicular loading based on 7ft backwall height (interpolate between 4 and 3 in the Table)}$$

STable 3.11.6.4-1

$$\Delta_p = k \cdot \gamma_s \cdot h_{eq}$$

$$\Delta_p = 0.130 \text{ ksf}$$

The lateral load due to the live load surcharge is:

$$R_{LSbw} = \Delta_p \cdot h_{bkwall}$$

$$R_{LSbw} = 0.91 \frac{\text{K}}{\text{ft}}$$

Bottom of abutment stem live load surcharge load:

$$k = k_a$$

$$\gamma_s = 0.120 \text{ kcf} \quad \text{use average of loose and compacted gravel}$$

STable 3.5.1-1

$$h_{eq} = 2 \text{ ft} \quad \text{equivalent height of soil for vehicular loading based on stem height}$$

STable 3.11.6.4-1

$$\Delta_p = k \cdot \gamma_s \cdot h_{eq}$$

$$\Delta_p = 0.072 \text{ ksf}$$

The lateral load due to the live load surcharge is:

$$R_{LSstem} = \Delta_p \cdot h_{stem}$$

$$R_{LSstem} = 1.58 \frac{K}{ft}$$

Bottom of footing live load surcharge load:

$$k = k_a$$

$$\gamma_s = 0.120 kcf \quad \text{use average of loose and compacted gravel}$$

$$h_{eq} = 2ft \quad \text{equivalent height of soil for vehicular loading}$$

$$\Delta_p = k \cdot \gamma_s \cdot h_{eq}$$

$$\Delta_p = 0.072 ksf$$

The lateral load due to the live load surcharge is:

$$R_{LSftg} = \Delta_p \cdot (h_{stem} + t_{ftg})$$

$$R_{LSftg} = 1.76 \frac{K}{ft}$$

Since one edge of the approach slab will be supported by the abutment, a reduction of live load surcharge could be taken into account. For this design example, a surcharge reduction is not accounted for.

Loads due to temperature:

For this abutment design example, two horizontal temperature loads need to be calculated: load due to temperature rise and load due to temperature fall. To calculate these loads, the steel girder setting temperature is required. Also, the temperature range, as well as the thermal coefficient of expansion for steel, is needed. The expansion or contraction can then be calculated. Using the expansion or contraction, the thermal loads can be calculated based on the neoprene bearing properties.

$$\varepsilon = 6.5 \times 10^{-6} \quad (\text{in/in/}^\circ\text{F})$$

$$t_{set} = 68 \text{ }^\circ\text{F} \quad \text{assumed steel girder setting temperature}$$

S3.5.1-1

S3.11.6.4-1

S3.11.6.5

S3.12

S3.12.2.2

S3.12.2.1-1

S6.4.1

S14.6.3.1

S6.4.1

For this design example, assume a moderate climate. The temperature range is then 0 °F to 120 °F

STable 3.12.2.1-1

Expansion calculation:

$$\Delta_{\text{exp}} = \varepsilon \cdot \Delta t \cdot \left(L_{\text{span}} \cdot 12 \frac{\text{in}}{\text{ft}} \right)$$

$$\Delta t_{\text{rise}} = 120 - t_{\text{set}}$$

$$\Delta t_{\text{rise}} = 52 \text{ } ^\circ\text{F}$$

$$\Delta_{\text{exp}} = \varepsilon \cdot \Delta t_{\text{rise}} \cdot \left(L_{\text{span}} \cdot 12 \frac{\text{in}}{\text{ft}} \right)$$

$$\Delta_{\text{exp}} = 0.487 \text{ in}$$

Contraction calculation:

$$\Delta_{\text{contr}} = \varepsilon \cdot \Delta t \cdot \left(L_{\text{span}} \cdot 12 \frac{\text{in}}{\text{ft}} \right)$$

$$\Delta t_{\text{fall}} = t_{\text{set}} - 0$$

$$\Delta t_{\text{fall}} = 68 \text{ } ^\circ\text{F}$$

$$\Delta_{\text{contr}} = \varepsilon \cdot \Delta t_{\text{fall}} \cdot \left(L_{\text{span}} \cdot 12 \frac{\text{in}}{\text{ft}} \right)$$

$$\Delta_{\text{contr}} = 0.636 \text{ in}$$

Once the expansion and contraction is known, the loads due to temperature can be calculated based on the following equation:

$$H_u = G \cdot A \cdot \frac{\Delta}{h_{rt}}$$

S14.6.3.1

Before the loads due to temperature rise and fall can be calculated, the neoprene bearing properties are needed (see Design Step 6). If the bearing pad design is not complete at the time the temperature loads are being calculated, the temperature loads can be estimated by assuming bearing pad properties that are larger than expected from the bearing pad design. The bearing pad properties for this design example are:

$$G = 0.095\text{ksi} \quad \text{shear modulus}$$

$$A = 14\text{in} \cdot 15\text{in} \quad \text{area of the bearing pad in plan view}$$

$$A = 210.00\text{in}^2$$

$$h_{rt} = 3.5\text{in} \quad \text{elastomer thickness (not including steel reinforcement)}$$

STable 14.7.5.2-1

Load due to temperature rise:

$$H_{urise} = G \cdot A \cdot \frac{\Delta_{exp}}{h_{rt}}$$

$$H_{urise} = 2.77\text{K} \quad \text{per bearing}$$

Now, multiply H_{urise} by five bearings and divide by the abutment length to get the total load due to temperature rise:

$$H_{urisetot} = \frac{H_{urise} \cdot 5}{L_{abut}}$$

$$H_{urisetot} = 0.30 \frac{\text{K}}{\text{ft}}$$

Load due to temperature fall:

$$H_{ufall} = G \cdot A \cdot \frac{\Delta_{contr}}{h_{rt}}$$

$$H_{ufall} = 3.63\text{K}$$

Now, multiply H_{ufall} by five bearings and divide by the abutment length to get the total load due to temperature fall:

$$H_{ufalltot} = \frac{H_{ufall} \cdot 5}{L_{abut}}$$

$$H_{ufalltot} = 0.39 \frac{\text{K}}{\text{ft}}$$

Design Step 7.7 - Analyze and Combine Force Effects

There are three critical locations where the force effects need to be combined and analyzed for an abutment design. They are the base or bottom of the backwall, the bottom of stem or top of footing, and the bottom of footing. For the backwall and stem design, transverse horizontal loads do not need to be considered due to the high moment of inertia about that axis, but at the bottom of footing, the transverse horizontal loads will need to be considered for the footing and pile design, although they are still minimal.

Bottom of Abutment Backwall

In order to analyze and combine the force effects, the abutment backwall dimensions, the appropriate loads, and the application location of the loads are needed. The small moment that is created by the top of the backwall corbel concrete will be neglected in this design example.

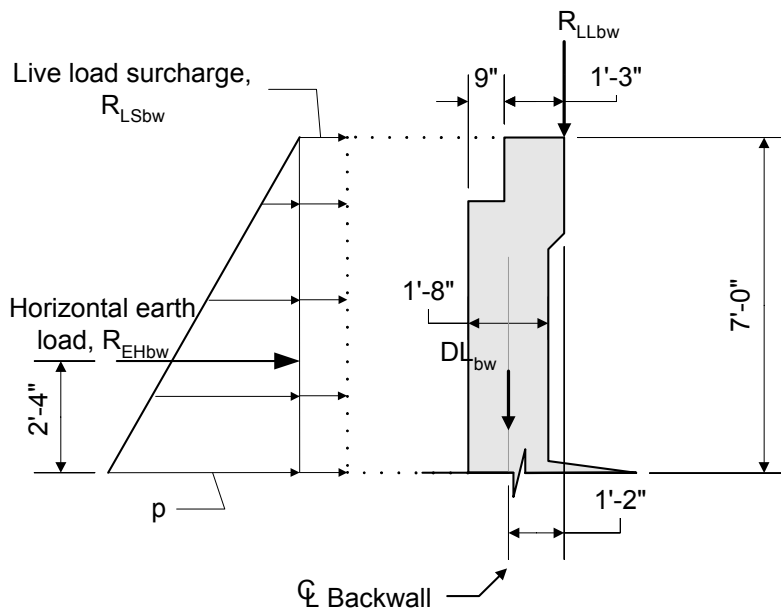

Figure 7-8 Abutment Backwall Dimensions and Loading

The following limit states will be investigated for the backwall analysis. The load factor for future wearing surface is given, but the load due to future wearing surface on the abutment backwall will be ignored since its effects are negligible. Also, limit states that are not shown either do not control or are not applicable. In addition, Strength III and Strength V limit states are included but generally will not control for an abutment with expansion bearings. Strength III or Strength V may control for abutments supporting fixed bearings.

Loads	Load Factors							
	Strength I		Strength III		Strength V		Service I	
	γ_{max}	γ_{min}	γ_{max}	γ_{min}	γ_{max}	γ_{min}	γ_{max}	γ_{min}
DC	1.25	0.90	1.25	0.90	1.25	0.90	1.00	1.00
DW	1.50	0.65	1.50	0.65	1.50	0.65	1.00	1.00
LL	1.75	1.75	---	---	1.35	1.35	1.00	1.00
EH	1.50	0.90	1.50	0.90	1.50	0.90	1.00	1.00
LS	1.75	1.75	---	---	1.35	1.35	1.00	1.00

STable 3.4.1-1

STable 3.4.1-2

Table 7-3 Applicable Abutment Backwall Limit States with the Corresponding Load Factors

The loads that are required from Design Steps 7.4, 7.5, and 7.6 include:

$$DL_{bw} = 1.71 \frac{K}{ft} \qquad R_{EHbw} = 0.88 \frac{K}{ft}$$

$$R_{LLbw} = 2.81 \frac{K}{ft} \qquad R_{LSbw} = 0.91 \frac{K}{ft}$$

Abutment backwall Strength I force effects:

The following load factors will be used to calculate the force effects for Strength I. Note that eta (η), the product of ductility, redundancy, and operational importance factors, is not shown. Eta is discussed in detail in Design Step 1. For all portions of this design example, eta is taken as 1.0, and will not be shown.

$$\gamma_{DC} = 1.25$$

$$\gamma_{LL} = 1.75$$

$$\gamma_{EH} = 1.50$$

$$\gamma_{LS} = 1.75$$

STable 3.4.1-2

STable 3.4.1-1

STable 3.4.1-2

STable 3.4.1-1

The factored vertical force at the base of the backwall is:

$$F_{vbwstrI} = \gamma_{DC} \cdot DL_{bw} + \gamma_{LL} \cdot R_{LLbw}$$

$$F_{vbwstrI} = 7.05 \frac{K}{ft}$$

The factored longitudinal shear force at the base of the backwall is:

$$V_{ubwstrI} = (\gamma_{EH} \cdot R_{EHbw}) + (\gamma_{LS} \cdot R_{LSbw})$$

$$V_{ubwstrI} = 2.91 \frac{K}{ft}$$

The factored moment at the base of the backwall is:

$$M_{ubwstrI} = (\gamma_{LL} \cdot R_{LLbw} \cdot 1.17 \cdot ft) + (\gamma_{EH} \cdot R_{EHbw} \cdot 2.33 \cdot ft) \dots \\ + (\gamma_{LS} \cdot R_{LSbw} \cdot 3.50 \cdot ft)$$

$$M_{ubwstrI} = 14.38 \frac{K \cdot ft}{ft}$$

Abutment backwall Strength III force effects:

The following load factors will be used to calculate the force effects for Strength III:

$$\gamma_{DC} = 1.25$$

$$\gamma_{LL} = 0.00$$

$$\gamma_{EH} = 1.50$$

$$\gamma_{LS} = 0.00$$

STable 3.4.1-2

STable 3.4.1-1

STable 3.4.1-2

STable 3.4.1-1

The factored vertical force at the base of the backwall is:

$$F_{vbwstrIII} = \gamma_{DC} \cdot DL_{bw} + \gamma_{LL} \cdot R_{LLbw}$$

$$F_{vbwstrIII} = 2.14 \frac{K}{ft}$$

The factored longitudinal shear force at the base of the backwall is:

$$V_{ubwstrIII} = (\gamma_{EH} \cdot R_{EHbw}) + (\gamma_{LS} \cdot R_{LSbw})$$

$$V_{ubwstrIII} = 1.32 \frac{K}{ft}$$

The factored moment at the base of the backwall is:

$$M_{ubwstrIII} = (\gamma_{LL} \cdot R_{LLbw} \cdot 1.17 \cdot \text{ft}) + (\gamma_{EH} \cdot R_{EHbw} \cdot 2.33 \cdot \text{ft}) \dots \\ + (\gamma_{LS} \cdot R_{LSbw} \cdot 3.50 \cdot \text{ft})$$

$$M_{ubwstrIII} = 3.08 \frac{\text{K} \cdot \text{ft}}{\text{ft}}$$

Abutment backwall Strength V force effects:

The following load factors will be used to calculate the force effects for Strength V:

$$\gamma_{DC} = 1.25$$

$$\gamma_{LL} = 1.35$$

$$\gamma_{EH} = 1.50$$

$$\gamma_{LS} = 1.35$$

STable 3.4.1-2

STable 3.4.1-1

STable 3.4.1-2

STable 3.4.1-1

The factored vertical force at the base of the backwall is:

$$F_{vbwstrV} = \gamma_{DC} \cdot DL_{bw} + \gamma_{LL} \cdot R_{LLbw}$$

$$F_{vbwstrV} = 5.93 \frac{\text{K}}{\text{ft}}$$

The factored longitudinal shear force at the base of the backwall is:

$$V_{ubwstrV} = (\gamma_{EH} \cdot R_{EHbw}) + (\gamma_{LS} \cdot R_{LSbw})$$

$$V_{ubwstrV} = 2.55 \frac{\text{K}}{\text{ft}}$$

The factored moment at the base of the backwall is:

$$M_{ubwstrV} = (\gamma_{LL} \cdot R_{LLbw} \cdot 1.17 \cdot \text{ft}) + (\gamma_{EH} \cdot R_{EHbw} \cdot 2.33 \cdot \text{ft}) \dots \\ + (\gamma_{LS} \cdot R_{LSbw} \cdot 3.50 \cdot \text{ft})$$

$$M_{ubwstrV} = 11.80 \frac{\text{K} \cdot \text{ft}}{\text{ft}}$$

Abutment backwall Service I force effects:

The following load factors will be used to calculate the force effects for Service I:

$$\gamma_{DC} = 1.0$$

$$\gamma_{LL} = 1.0$$

$$\gamma_{EH} = 1.0$$

$$\gamma_{LS} = 1.0$$

STable 3.4.1-2

STable 3.4.1-1

STable 3.4.1-2

STable 3.4.1-1

The factored vertical force at the base of the backwall is:

$$F_{vbwservi} = \gamma_{DC} \cdot DL_{bw} + \gamma_{LL} \cdot R_{LLbw}$$

$$F_{vbwservi} = 4.52 \frac{K}{ft}$$

The factored longitudinal shear force at the base of the backwall is:

$$V_{ubwservi} = (\gamma_{EH} \cdot R_{EHbw}) + (\gamma_{LS} \cdot R_{LSbw})$$

$$V_{ubwservi} = 1.79 \frac{K}{ft}$$

The factored moment at the base of the backwall is:

$$M_{ubwservi} = (\gamma_{LL} \cdot R_{LLbw} \cdot 1.17 \cdot ft) + (\gamma_{EH} \cdot R_{EHbw} \cdot 2.33 \cdot ft) \dots \\ + (\gamma_{LS} \cdot R_{LSbw} \cdot 3.50 \cdot ft)$$

$$M_{ubwservi} = 8.51 \frac{K \cdot ft}{ft}$$

The maximum factored backwall vertical force, shear force, and moment for the strength limit state are:

$$F_{vbwmax} = \max(F_{vbwstrI}, F_{vbwstrIII}, F_{vbwstrV})$$

$$F_{vbwmax} = 7.05 \frac{K}{ft}$$

$$V_{ubwmax} = \max(V_{ubwstrI}, V_{ubwstrIII}, V_{ubwstrV})$$

$$V_{ubwmax} = 2.91 \frac{K}{ft}$$

$$M_{ubwmax} = \max(M_{ubwstrI}, M_{ubwstrIII}, M_{ubwstrV})$$

$$M_{ubwmax} = 14.38 \frac{K \cdot ft}{ft}$$

Bottom of Abutment Stem

The combination of force effects for the bottom of abutment stem are similar to the backwall with the addition of the superstructure dead and live loads.

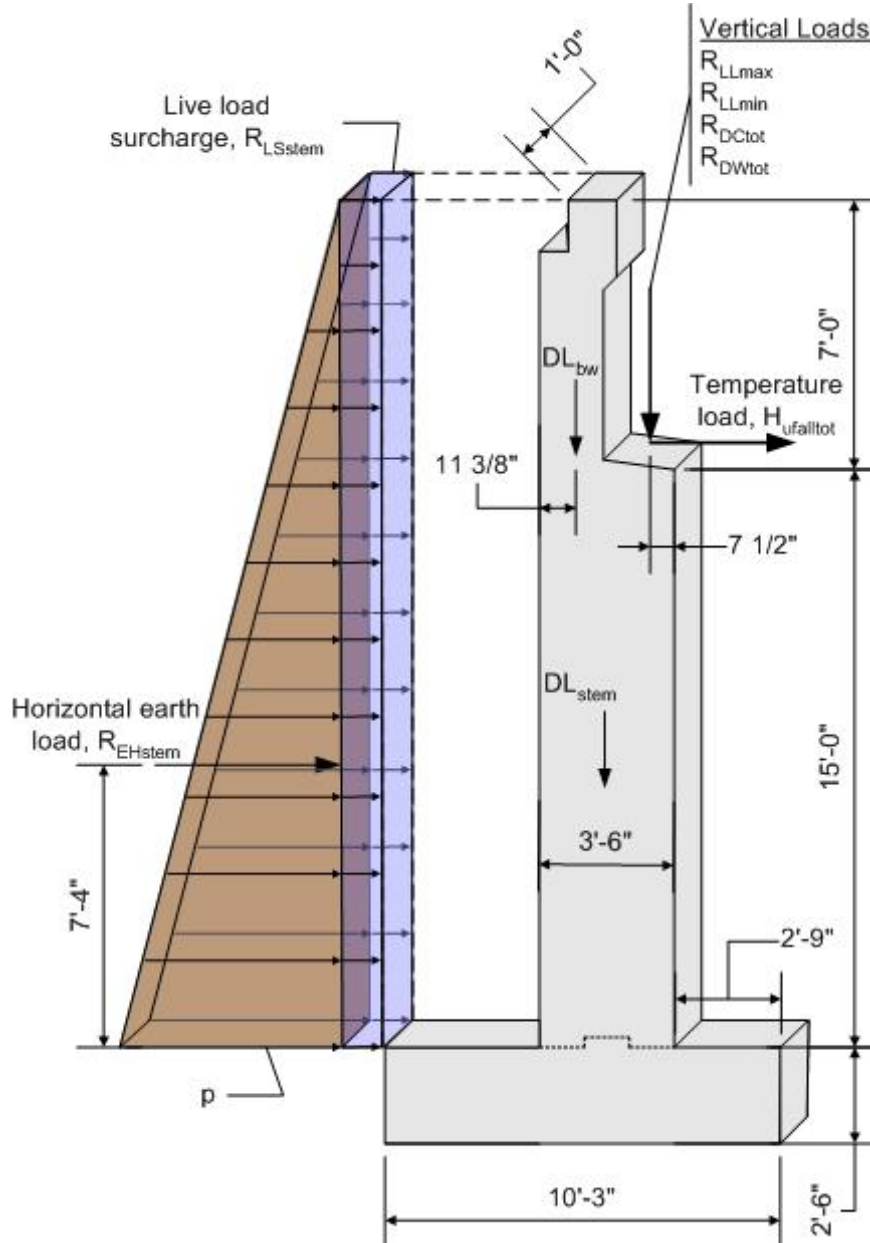

Figure 7-9 Abutment Stem Dimensions and Loading

The force effects for the stem will be combined for the same limit states as the backwall. The loads and load factors are also similar to the backwall with the addition of wind on structure, wind on live load, and thermal effects. As with the backwall, the extreme event limit states will not be investigated.

Loads	Load Factors							
	Strength I		Strength III		Strength V		Service I	
	γ_{max}	γ_{min}	γ_{max}	γ_{min}	γ_{max}	γ_{min}	γ_{max}	γ_{min}
DC	1.25	0.90	1.25	0.90	1.25	0.90	1.00	1.00
DW	1.50	0.65	1.50	0.65	1.50	0.65	1.00	1.00
LL	1.75	1.75	---	---	1.35	1.35	1.00	1.00
EH	1.50	0.90	1.50	0.90	1.50	0.90	1.00	1.00
LS	1.75	1.75	---	---	1.35	1.35	1.00	1.00
WS	---	---	1.40	1.40	0.40	0.40	0.30	0.30
WL	---	---	---	---	1.00	1.00	1.00	1.00
TU	0.50	0.50	0.50	0.50	0.50	0.50	1.00	1.00

STable 3.4.1-1

STable 3.4.1-2

Table 7-4 Applicable Abutment Stem Limit States with the Corresponding Load Factors

The loads that are required from Design Steps 7.4, 7.5 and 7.6 include:

$$DL_{bw} = 1.71 \frac{K}{ft}$$

$$R_{LLmax} = 6.50 \frac{K}{ft}$$

$$DL_{stem} = 7.88 \frac{K}{ft}$$

$$R_{EHstem} = 8.71 \frac{K}{ft}$$

$$R_{DCtot} = 7.66 \frac{K}{ft}$$

$$R_{LSstem} = 1.58 \frac{K}{ft}$$

$$R_{DWtot} = 1.20 \frac{K}{ft}$$

$$H_{ufalltot} = 0.39 \frac{K}{ft}$$

Abutment stem Strength I force effects:

The following load factors will be used to calculate the controlling force effects for Strength I:

$$\gamma_{DC} = 1.25$$

STable 3.4.1-2

$$\gamma_{DW} = 1.50$$

STable 3.4.1-2

$$\gamma_{LL} = 1.75$$

STable 3.4.1-1

$$\gamma_{EH} = 1.50$$

STable 3.4.1-2

$$\gamma_{LS} = 1.75$$

STable 3.4.1-1

$$\gamma_{TU} = 0.50$$

use contraction temperature force

STable 3.4.1-1

The factored vertical force at the base of the abutment stem is:

$$F_{vstemstrl} = (\gamma_{DC} \cdot DL_{bw}) + (\gamma_{DC} \cdot DL_{stem}) + (\gamma_{DC} \cdot R_{DCtot}) \dots \\ + (\gamma_{DW} \cdot R_{DWtot}) + (\gamma_{LL} \cdot R_{LLmax})$$

$$F_{vstemstrl} = 34.74 \frac{K}{ft}$$

The factored longitudinal shear force at the base of the stem is:

$$V_{ustemstrl} = (\gamma_{EH} \cdot R_{EHstem}) + (\gamma_{LS} \cdot R_{LSstem}) \dots \\ + (\gamma_{TU} \cdot H_{ufalltot})$$

$$V_{ustemstrl} = 16.03 \frac{K}{ft}$$

The factored moment about the bridge transverse axis at the base of the abutment stem is:

$$M_{ustemstrl} = (\gamma_{DC} \cdot DL_{bw} \cdot 0.80 \cdot ft) + (\gamma_{DC} \cdot R_{DCtot} \cdot 1.13 \cdot ft) \dots \\ + (\gamma_{DW} \cdot R_{DWtot} \cdot 1.13 \cdot ft) + (\gamma_{LL} \cdot R_{LLmax} \cdot 1.13 \cdot ft) \dots \\ + (\gamma_{EH} \cdot R_{EHstem} \cdot 7.33 \cdot ft) + (\gamma_{LS} \cdot R_{LSstem} \cdot 11.00 \cdot ft) \dots \\ + (\gamma_{TU} \cdot H_{ufalltot} \cdot 15 \cdot ft)$$

$$M_{ustemstrl} = 156.61 \frac{K \cdot ft}{ft}$$

Abutment stem Strength III force effects:

The following load factors will be used to calculate the force effects for Strength III:

$$\gamma_{DC} = 1.25$$

$$\gamma_{DW} = 1.50$$

$$\gamma_{EH} = 1.50$$

$$\gamma_{WS} = 1.40 \quad \text{all longitudinal wind loads ignored}$$

$$\gamma_{TU} = 0.50 \quad \text{use contraction temperature force}$$

STable 3.4.1-2

STable 3.4.1-2

STable 3.4.1-2

STable 3.4.1-1

STable 3.4.1-1

The factored vertical force at the base of the abutment stem is:

$$F_{vstemstrIII} = (\gamma_{DC} \cdot DL_{bw}) + (\gamma_{DC} \cdot DL_{stem}) \dots \\ + (\gamma_{DC} \cdot R_{DCtot}) + (\gamma_{DW} \cdot R_{DWtot})$$

$$F_{vstemstrIII} = 23.36 \frac{K}{ft}$$

The factored longitudinal shear force at the base of the stem is:

$$V_{ustemstrIII} = (\gamma_{EH} \cdot R_{EHstem}) + (\gamma_{TU} \cdot H_{ufalltot})$$

$$V_{ustemstrIII} = 13.26 \frac{K}{ft}$$

The factored moment about the bridge transverse axis at the base of the abutment stem is:

$$M_{ustemstrIII} = (\gamma_{DC} \cdot DL_{bw} \cdot 0.80 \cdot ft) + (\gamma_{DC} \cdot R_{DCtot} \cdot 1.13 \cdot ft) \dots \\ + (\gamma_{DW} \cdot R_{DWtot} \cdot 1.13 \cdot ft) + (\gamma_{EH} \cdot R_{EHstem} \cdot 7.33 \cdot ft) \dots \\ + (\gamma_{TU} \cdot H_{ufalltot} \cdot 15 \cdot ft)$$

$$M_{ustemstrIII} = 113.25 \frac{K \cdot ft}{ft}$$

Abutment stem Strength V force effects:

The following load factors will be used to calculate the force effects for Strength V:

$$\gamma_{DC} = 1.25$$

STable 3.4.1-2

$$\gamma_{DW} = 1.50$$

STable 3.4.1-2

$$\gamma_{LL} = 1.35$$

STable 3.4.1-1

$$\gamma_{EH} = 1.50$$

STable 3.4.1-2

$$\gamma_{LS} = 1.35$$

STable 3.4.1-1

$$\gamma_{WS} = 0.40$$

all longitudinal wind loads ignored

STable 3.4.1-1

$$\gamma_{WL} = 1.00$$

only applicable for wind angle of 0 degrees

STable 3.4.1-1

$$\gamma_{TU} = 0.50$$

use contraction temperature force

STable 3.4.1-1

The factored vertical force at the base of the abutment stem is:

$$F_{vstemstrV} = (\gamma_{DC} \cdot DL_{bw}) + (\gamma_{DC} \cdot DL_{stem}) \dots \\ + (\gamma_{DC} \cdot R_{DCtot}) + (\gamma_{DW} \cdot R_{DWtot}) \dots \\ + (\gamma_{LL} \cdot R_{LLmax})$$

$$F_{vstemstrV} = 32.14 \frac{K}{ft}$$

The factored longitudinal shear force at the base of the stem is:

$$V_{ustemstrV} = (\gamma_{EH} \cdot R_{EHstem}) + (\gamma_{LS} \cdot R_{LSstem}) \dots \\ + (\gamma_{TU} \cdot H_{ufalltot})$$

$$V_{ustemstrV} = 15.40 \frac{K}{ft}$$

The factored moment about the bridge transverse axis at the base of the abutment stem is:

$$M_{ustemstrV} = (\gamma_{DC} \cdot DL_{bw} \cdot 0.80 \cdot ft) + (\gamma_{DC} \cdot R_{DCtot} \cdot 1.13 \cdot ft) \dots \\ + (\gamma_{DW} \cdot R_{DWtot} \cdot 1.13 \cdot ft) + (\gamma_{LL} \cdot R_{LLmax} \cdot 1.13 \cdot ft) \dots \\ + (\gamma_{EH} \cdot R_{EHstem} \cdot 7.33 \cdot ft) + (\gamma_{LS} \cdot R_{LSstem} \cdot 11.00 \cdot ft) \dots \\ + (\gamma_{TU} \cdot H_{ufalltot} \cdot 15 \cdot ft)$$

$$M_{ustemstrV} = 146.70 \frac{K \cdot ft}{ft}$$

Abutment stem Service I force effects:

The following load factors will be used to calculate the force effects for Service I:

$$\gamma_{DC} = 1.00$$

STable 3.4.1-2

$$\gamma_{DW} = 1.00$$

STable 3.4.1-2

$$\gamma_{LL} = 1.00$$

STable 3.4.1-1

$$\gamma_{EH} = 1.00$$

STable 3.4.1-2

$$\gamma_{LS} = 1.00$$

STable 3.4.1-1

$$\gamma_{WS} = 0.30$$

use for wind on stem end face for
controlling wind at 60 degrees

STable 3.4.1-1

$$\gamma_{WL} = 1.00$$

only applicable for wind angle of 0 degrees

STable 3.4.1-1

$$\gamma_{TU} = 1.00$$

use contraction temperature force

STable 3.4.1-1

The factored vertical force at the base of the abutment stem is:

$$F_{vstemserVI} = (\gamma_{DC} \cdot DL_{bw}) + (\gamma_{DC} \cdot DL_{stem}) \dots \\ + (\gamma_{DC} \cdot R_{DCtot}) + (\gamma_{DW} \cdot R_{DWtot}) \dots \\ + (\gamma_{LL} \cdot R_{LLmax})$$

$$F_{vstemserVI} = 24.95 \frac{K}{ft}$$

The factored longitudinal shear force at the base of the stem is:

$$V_{ustemserVI} = (\gamma_{EH} \cdot R_{EHstem}) + (\gamma_{LS} \cdot R_{LSstem}) \dots \\ + (\gamma_{TU} \cdot H_{ufalltot})$$

$$V_{ustemserVI} = 10.68 \frac{K}{ft}$$

The factored moment about the bridge transverse axis at the base of the abutment stem is:

$$M_{\text{ustemservl}} = (\gamma_{\text{DC}} \cdot \text{DL}_{\text{bw}} \cdot 0.80 \cdot \text{ft}) + (\gamma_{\text{DC}} \cdot \text{R}_{\text{DCtot}} \cdot 1.13 \cdot \text{ft}) \dots \\ + (\gamma_{\text{DW}} \cdot \text{R}_{\text{DWtot}} \cdot 1.13 \cdot \text{ft}) + (\gamma_{\text{LL}} \cdot \text{R}_{\text{LLmax}} \cdot 1.13 \cdot \text{ft}) \dots \\ + (\gamma_{\text{EH}} \cdot \text{R}_{\text{EHstem}} \cdot 7.33 \cdot \text{ft}) + (\gamma_{\text{LS}} \cdot \text{R}_{\text{LSstem}} \cdot 11.00 \cdot \text{ft}) \dots \\ + (\gamma_{\text{TU}} \cdot \text{H}_{\text{ufalltot}} \cdot 15 \cdot \text{ft})$$

$$M_{\text{ustemservl}} = 105.82 \frac{\text{K} \cdot \text{ft}}{\text{ft}}$$

The maximum factored abutment stem vertical force, shear force, and moment for the strength limit state are:

$$F_{\text{vstemmax}} = \max(F_{\text{vstemstrI}}, F_{\text{vstemstrIII}}, F_{\text{vstemstrV}})$$

$$F_{\text{vstemmax}} = 34.74 \frac{\text{K}}{\text{ft}}$$

$$V_{\text{ustemmax}} = \max(V_{\text{ustemstrI}}, V_{\text{ustemstrIII}}, V_{\text{ustemstrV}})$$

$$V_{\text{ustemmax}} = 16.03 \frac{\text{K}}{\text{ft}}$$

$$M_{\text{ustemmax}} = \max(M_{\text{ustemstrI}}, M_{\text{ustemstrIII}}, M_{\text{ustemstrV}})$$

$$M_{\text{ustemmax}} = 156.61 \frac{\text{K} \cdot \text{ft}}{\text{ft}}$$

Bottom of Abutment Footing

The combination of force effects for the bottom of abutment footing are similar to the backwall and stem with the addition of the earth load on the abutment heel. Also, dynamic load allowance must be removed from the live load portion of the force effects for foundation components that are completely below the ground level.

S3.6.2.1

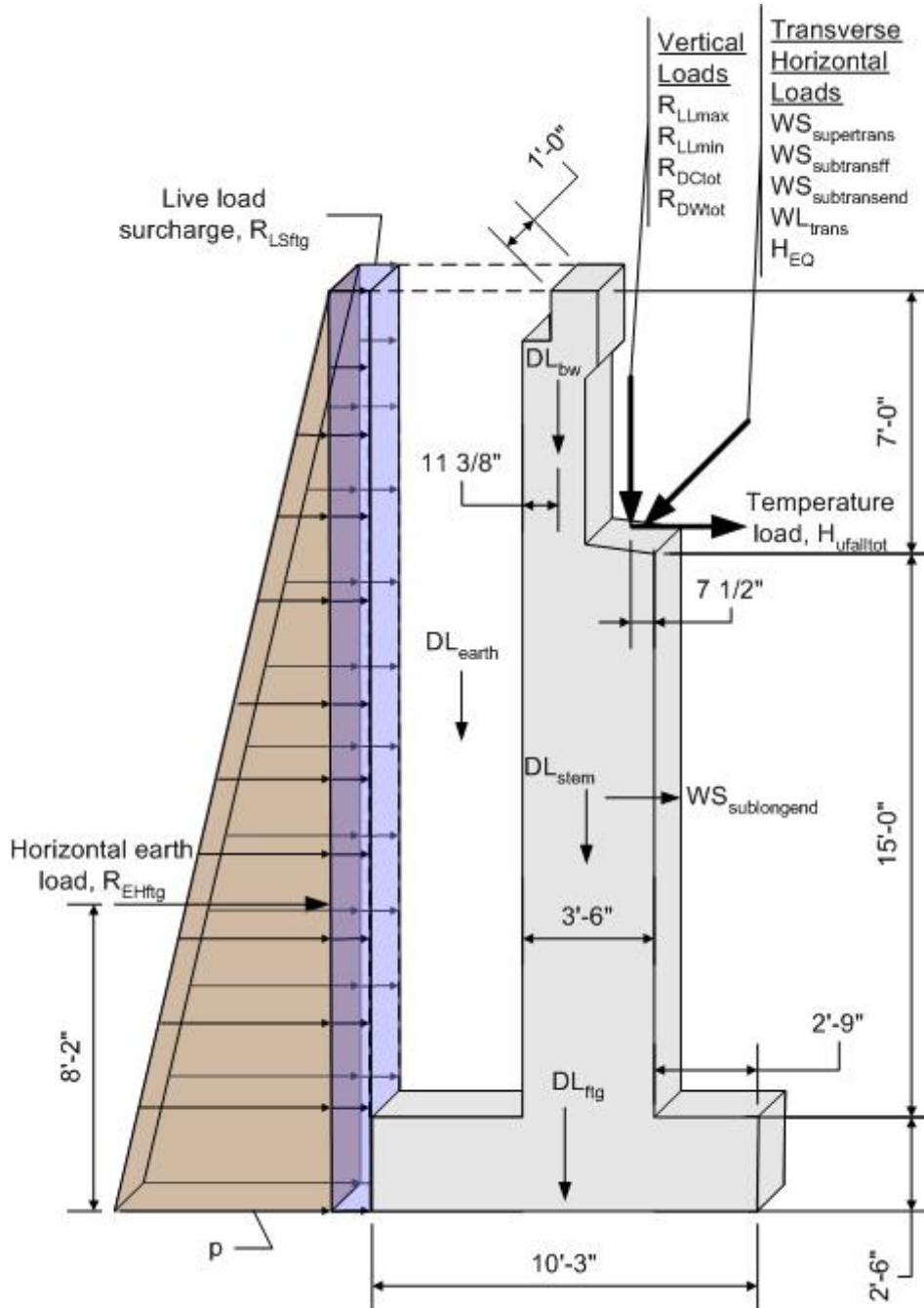

Figure 7-10 Abutment Footing Dimensions and Loading

The force effects for the bottom of footing will be combined for the same limit states as the backwall and stem. The loads and load factors are also similar with the addition of vertical earth load.

Loads	Load Factors							
	Strength I		Strength III		Strength V		Service I	
	γ_{max}	γ_{min}	γ_{max}	γ_{min}	γ_{max}	γ_{min}	γ_{max}	γ_{min}
DC	1.25	0.90	1.25	0.90	1.25	0.90	1.00	1.00
DW	1.50	0.65	1.50	0.65	1.50	0.65	1.00	1.00
LL	1.75	1.75	---	---	1.35	1.35	1.00	1.00
EH	1.50	0.90	1.50	0.90	1.50	0.90	1.00	1.00
EV	1.35	1.00	1.35	1.00	1.35	1.00	1.00	1.00
LS	1.75	1.75	---	---	1.35	1.35	1.00	1.00
WS	---	---	1.40	1.40	0.40	0.40	0.30	0.30
WL	---	---	---	---	1.00	1.00	1.00	1.00
TU	0.50	0.50	0.50	0.50	0.50	0.50	1.00	1.00

STable 3.4.1-1

STable 3.4.1-2

Table 7-5 Applicable Abutment Footing Limit States with the Corresponding Load Factors

The loads that are required from Design Steps 7.4, 7.5, and 7.6 include:

$$DL_{bw} = 1.71 \frac{K}{ft}$$

$$R_{EHftg} = 10.80 \frac{K}{ft}$$

$$DL_{stem} = 7.88 \frac{K}{ft}$$

$$R_{LSftg} = 1.76 \frac{K}{ft}$$

$$DL_{ftg} = 3.84 \frac{K}{ft}$$

$$H_{ufalltot} = 0.39 \frac{K}{ft}$$

$$DL_{earth} = 10.56 \frac{K}{ft}$$

$$WS_{supertrans0} = 30.69 K$$

$$R_{DCtot} = 7.66 \frac{K}{ft}$$

$$WS_{subtransend0} = 3.08 K$$

$$R_{DWtot} = 1.20 \frac{K}{ft}$$

$$WL_{trans0} = 6.00 K$$

$$R_{LLmin1} = -0.68 \frac{K}{ft}$$

$$WS_{subtransend60} = 1.54 K$$

$$R_{LLmax1} = 5.34 \frac{K}{ft}$$

$$WS_{sublongend60} = 2.67 K$$

Abutment bottom of footing Strength I force effects using the maximum load factors:

The following load factors will be used to calculate the controlling force effects for Strength I:

$$\gamma_{DC} = 1.25$$

STable 3.4.1-2

$$\gamma_{DW} = 1.50$$

STable 3.4.1-2

$$\gamma_{LL} = 1.75$$

STable 3.4.1-1

$$\gamma_{EH} = 1.50$$

STable 3.4.1-2

$$\gamma_{EV} = 1.35$$

use maximum value to maximize the pile loads

STable 3.4.1-2

$$\gamma_{LS} = 1.75$$

STable 3.4.1-1

$$\gamma_{TU} = 0.50$$

use contraction temperature force

STable 3.4.1-1

The factored vertical force at the bottom of footing is:

$$F_{vftgstrl} = (\gamma_{DC} \cdot DL_{bw}) + (\gamma_{DC} \cdot DL_{stem}) \dots \\ + (\gamma_{DC} \cdot DL_{ftg}) + (\gamma_{EV} \cdot DL_{earth}) \dots \\ + (\gamma_{DC} \cdot R_{DCtot}) + (\gamma_{DW} \cdot R_{DWtot}) \dots \\ + (\gamma_{LL} \cdot R_{LLmax1})$$

$$F_{vftgstrl} = 51.76 \frac{K}{ft}$$

The factored longitudinal horizontal force at the bottom of footing is:

$$F_{lonftgstrl} = \left[(\gamma_{EH} \cdot R_{EHftg}) + (\gamma_{LS} \cdot R_{LSftg}) \dots \right] \\ + (\gamma_{TU} \cdot H_{ufalltot})$$

$$F_{lonftgstrl} = 19.49 \frac{K}{ft}$$

The factored transverse horizontal force at the bottom of footing is:

$$F_{traftgstrl} = 0 \frac{K}{ft}$$

The load factors for the loads that produce transverse horizontal forces are zero for Strength I.

The factored moment about the bridge transverse axis at the bottom of footing is:

$$\begin{aligned}
 M_{\text{lonftgstrl}} = & \left[\gamma_{\text{DC}} \cdot (DL_{\text{bw}}) \cdot (-0.177 \cdot \text{ft}) \right] \dots \\
 & + \left[\gamma_{\text{DC}} \cdot (DL_{\text{stem}}) \cdot (0.625 \cdot \text{ft}) \right] \dots \\
 & + \left[\gamma_{\text{EV}} \cdot DL_{\text{earth}} \cdot (-3.125 \cdot \text{ft}) \right] \dots \\
 & + \left(\gamma_{\text{DC}} \cdot R_{\text{DCtot}} \cdot 1.75 \cdot \text{ft} \right) \dots \\
 & + \left(\gamma_{\text{DW}} \cdot R_{\text{DWtot}} \cdot 1.75 \cdot \text{ft} \right) \dots \\
 & + \left(\gamma_{\text{LL}} \cdot R_{\text{LLmax1}} \cdot 1.75 \cdot \text{ft} \right) \dots \\
 & + \left(\gamma_{\text{EH}} \cdot R_{\text{EHftg}} \cdot 8.17 \cdot \text{ft} \right) \dots \\
 & + \left(\gamma_{\text{LS}} \cdot R_{\text{LSftg}} \cdot 12.25 \cdot \text{ft} \right) \dots \\
 & + \left(\gamma_{\text{TU}} \cdot H_{\text{ufalltot}} \cdot 17.5 \cdot \text{ft} \right)
 \end{aligned}$$

$$M_{\text{lonftgstrl}} = 171.09 \frac{\text{K} \cdot \text{ft}}{\text{ft}}$$

The factored moment about the bridge longitudinal axis at the bottom of footing is:

$$M_{\text{traftgstrl}} = 0 \frac{\text{K} \cdot \text{ft}}{\text{ft}}$$

The load factors for the loads that produce transverse horizontal forces are zero for Strength I.

Abutment bottom of footing Strength I force effects using the minimum load factors:

The following load factors will be used to calculate the controlling force effects for Strength I:

$$\gamma_{\text{DC}} = 0.90$$

STable 3.4.1-2

$$\gamma_{\text{DW}} = 0.65$$

STable 3.4.1-2

$$\gamma_{\text{LL}} = 1.75$$

STable 3.4.1-1

$$\gamma_{\text{EH}} = 0.90$$

STable 3.4.1-2

$$\gamma_{\text{EV}} = 1.00$$

use minimum value to minimize the pile loads

STable 3.4.1-2

$$\gamma_{\text{LS}} = 1.75$$

STable 3.4.1-1

$$\gamma_{\text{TU}} = 0.50$$

use contraction temperature force

STable 3.4.1-1

The factored vertical force at the bottom of footing is:

$$F_{vftgstrlmin} = (\gamma_{DC} \cdot DL_{bw}) + (\gamma_{DC} \cdot DL_{stem}) \dots \\ + (\gamma_{DC} \cdot DL_{ftg}) + (\gamma_{EV} \cdot DL_{earth}) \dots \\ + (\gamma_{DC} \cdot R_{DCtot}) + (\gamma_{DW} \cdot R_{DWtot}) \dots \\ + (\gamma_{LL} \cdot R_{LLmin1})$$

$$F_{vftgstrlmin} = 29.14 \frac{K}{ft}$$

The factored longitudinal horizontal force at the bottom of footing is:

$$F_{lonftgstrlmin} = (\gamma_{EH} \cdot R_{EHftg}) + (\gamma_{LS} \cdot R_{LSftg}) \dots \\ + (\gamma_{TU} \cdot H_{ufalltot})$$

$$F_{lonftgstrlmin} = 13.00 \frac{K}{ft}$$

The factored transverse horizontal force at the bottom of footing is:

$$F_{traftgstrlmin} = 0 \frac{K}{ft} \quad \text{The load factors for the loads that produce transverse horizontal forces are zero for Strength I.}$$

The factored moment about the bridge transverse axis at the bottom of footing is:

$$M_{lonftgstrlmin} = [\gamma_{DC} \cdot (DL_{bw}) \cdot (-0.177 \cdot ft)] \dots \\ + [\gamma_{DC} \cdot (DL_{stem}) \cdot (0.625 \cdot ft)] \dots \\ + [\gamma_{EV} \cdot DL_{earth} \cdot (-3.125 \cdot ft)] \dots \\ + (\gamma_{DC} \cdot R_{DCtot} \cdot 1.75 \cdot ft) \dots \\ + (\gamma_{DW} \cdot R_{DWtot} \cdot 1.75 \cdot ft) \dots \\ + (\gamma_{LL} \cdot R_{LLmin1} \cdot 1.75 \cdot ft) \dots \\ + (\gamma_{EH} \cdot R_{EHftg} \cdot 8.17 \cdot ft) \dots \\ + (\gamma_{LS} \cdot R_{LSftg} \cdot 12.25 \cdot ft) \dots \\ + (\gamma_{TU} \cdot H_{ufalltot} \cdot 17.5 \cdot ft)$$

$$M_{lonftgstrlmin} = 103.16 \frac{K \cdot ft}{ft}$$

The factored moment about the bridge longitudinal axis at the bottom of footing is:

$$M_{\text{traftgstrlmin}} = 0 \frac{\text{K}}{\text{ft}}$$

The load factors for the loads that produce transverse horizontal forces are zero for Strength I.

Abutment bottom of footing Strength III force effects:



Load Combinations

There are numerous load factor combinations for each limit state as can be seen from *STables 3.4.1-1* and *3.4.1-2*. It is possible to check one limit state, such as Strength I, over and over again using many different load factor combinations to obtain the controlling factored effects. The engineer should use engineering judgement when selecting the most appropriate load factor for each individual load within a limit state.

For the Strength III force effects below, the horizontal earth load is factored by the maximum load factor while the vertical earth load is factored by the minimum factor to maximize the overturning moment.

S3.4.1

The following load factors will be used to calculate the force effects for Strength III:

$$\gamma_{DC} = 1.25$$

STable 3.4.1-2

$$\gamma_{DW} = 1.50$$

STable 3.4.1-2

$$\gamma_{EH} = 1.50$$

STable 3.4.1-2

$$\gamma_{EV} = 1.00$$

use minimum value to maximize the longitudinal moment

STable 3.4.1-2

$$\gamma_{WS} = 1.40$$

use a wind angle of 0 degrees

STable 3.4.1-1

$$\gamma_{TU} = 0.50$$

use contraction temperature force

STable 3.4.1-1

Vertical wind load will be ignored since the moment of inertia about the abutment longitudinal axis is so large.

The factored vertical force at the bottom of footing is:

$$F_{vftgstrIII} = (\gamma_{DC} \cdot DL_{bw}) + (\gamma_{DC} \cdot DL_{stem}) \dots \\ + (\gamma_{DC} \cdot DL_{ftg}) + (\gamma_{EV} \cdot DL_{earth}) \dots \\ + (\gamma_{DC} \cdot R_{DCtot}) + (\gamma_{DW} \cdot R_{DWtot})$$

$$F_{vftgstrIII} = 38.72 \frac{K}{ft}$$

The factored longitudinal horizontal force at the bottom of footing is:

$$F_{lonftgstrIII} = (\gamma_{EH} \cdot R_{EHftg}) + (\gamma_{TU} \cdot H_{ufalltot})$$

$$F_{lonftgstrIII} = 16.40 \frac{K}{ft}$$

The factored transverse horizontal force at the bottom of footing is:

$$F_{traftgstrIII} = \gamma_{WS} \cdot \left(\frac{WS_{supertrans0}}{L_{abut}} + \frac{WS_{subtransend0}}{L_{abut}} \right)$$

$$F_{traftgstrIII} = 1.01 \frac{K}{ft}$$

The factored moment about the bridge transverse axis at the bottom of footing is:

$$M_{lonftgstrIII} = \left[\gamma_{DC} \cdot (DL_{bw}) \cdot (-0.177 \cdot ft) \right] \dots \\ + \left[\gamma_{DC} \cdot (DL_{stem}) \cdot 0.625 \cdot ft \right] \dots \\ + \left[\gamma_{EV} \cdot DL_{earth} \cdot (-3.125 \cdot ft) \right] \dots \\ + (\gamma_{DC} \cdot R_{DCtot} \cdot 1.75 \cdot ft) \dots \\ + (\gamma_{DW} \cdot R_{DWtot} \cdot 1.75 \cdot ft) \dots \\ + \left[\gamma_{WS} \cdot \left(\frac{WS_{sublongend0}}{L_{abut}} \right) \cdot 10 \cdot ft \right] \dots \\ + (\gamma_{EH} \cdot R_{EHftg} \cdot 8.17 \cdot ft) \dots \\ + (\gamma_{TU} \cdot H_{ufalltot} \cdot 17.5 \cdot ft)$$

$$M_{lonftgstrIII} = 128.47 \frac{K \cdot ft}{ft}$$

The factored moment about the bridge longitudinal axis at the bottom of footing is:

$$M_{\text{traftgstrIII}} = \gamma_{\text{WS}} \cdot \left(\frac{WS_{\text{supertrans0}}}{L_{\text{abut}}} \cdot 17.5 \cdot \text{ft} \right) \dots \\ + \gamma_{\text{WS}} \cdot \left(\frac{WS_{\text{subtransend0}}}{L_{\text{abut}}} \cdot 10 \cdot \text{ft} \right)$$

$$M_{\text{traftgstrIII}} = 16.96 \frac{\text{K} \cdot \text{ft}}{\text{ft}}$$

Abutment bottom of footing Strength V force effects:

The following load factors will be used to calculate the force effects for Strength V:

$$\gamma_{\text{DC}} = 1.25$$

STable 3.4.1-2

$$\gamma_{\text{DW}} = 1.50$$

STable 3.4.1-2

$$\gamma_{\text{LL}} = 1.35$$

STable 3.4.1-1

$$\gamma_{\text{EH}} = 1.50$$

STable 3.4.1-2

$$\gamma_{\text{EV}} = 1.00$$

use minimum value to maximize the longitudinal moment

STable 3.4.1-2

$$\gamma_{\text{LS}} = 1.35$$

STable 3.4.1-1

$$\gamma_{\text{WS}} = 0.40$$

use a wind angle of 0 degrees

STable 3.4.1-1

$$\gamma_{\text{WL}} = 1.00$$

STable 3.4.1-1

$$\gamma_{\text{TU}} = 0.50$$

use contraction temperature force

STable 3.4.1-1

The factored vertical force at the bottom of footing is:

$$F_{\text{vftgstrV}} = (\gamma_{\text{DC}} \cdot DL_{\text{bw}}) + (\gamma_{\text{DC}} \cdot DL_{\text{stem}}) \dots \\ + (\gamma_{\text{DC}} \cdot DL_{\text{ftg}}) + (\gamma_{\text{EV}} \cdot DL_{\text{earth}}) \dots \\ + (\gamma_{\text{DC}} \cdot R_{\text{DCtot}}) + (\gamma_{\text{DW}} \cdot R_{\text{DWtot}}) \dots \\ + (\gamma_{\text{LL}} \cdot R_{\text{LLmax1}})$$

$$F_{\text{vftgstrV}} = 45.93 \frac{\text{K}}{\text{ft}}$$

The factored longitudinal horizontal force at the bottom of footing is:

$$F_{\text{lonftgstrV}} = (\gamma_{EH} \cdot R_{EH\text{ftg}}) + (\gamma_{LS} \cdot R_{LS\text{ftg}}) \dots \\ + \left(\gamma_{WS} \cdot \frac{WS_{\text{sublongend0}}}{L_{\text{abut}}} \right) + (\gamma_{TU} \cdot H_{\text{ufalltot}})$$

$$F_{\text{lonftgstrV}} = 18.78 \frac{\text{K}}{\text{ft}}$$

The factored transverse shear force at the bottom of footing is:

$$F_{\text{traftgstrV}} = \gamma_{WS} \cdot \left(\frac{WS_{\text{supertrans0}}}{L_{\text{abut}}} + \frac{WS_{\text{subtransend0}}}{L_{\text{abut}}} \right) \dots \\ + \gamma_{WL} \cdot \left(\frac{WL_{\text{trans0}}}{L_{\text{abut}}} \right)$$

$$F_{\text{traftgstrV}} = 0.42 \frac{\text{K}}{\text{ft}}$$

The factored moment about the bridge transverse axis at the bottom of footing is:

$$M_{\text{lonftgstrV}} = \left[\gamma_{DC} \cdot (DL_{\text{bw}}) \cdot (-0.177 \cdot \text{ft}) \right] \dots \\ + \left[\gamma_{DC} \cdot (DL_{\text{stem}}) \cdot 0.625 \cdot \text{ft} \right] \dots \\ + \left[\gamma_{EV} \cdot DL_{\text{earth}} \cdot (-3.125 \cdot \text{ft}) \right] \dots \\ + (\gamma_{DC} \cdot R_{DC\text{tot}} \cdot 1.75 \cdot \text{ft}) \dots \\ + (\gamma_{DW} \cdot R_{DW\text{tot}} \cdot 1.75 \cdot \text{ft}) \dots \\ + (\gamma_{LL} \cdot R_{LL\text{max1}} \cdot 1.75 \cdot \text{ft}) \dots \\ + \left(\gamma_{WS} \cdot \frac{WS_{\text{sublongend0}}}{L_{\text{abut}}} \cdot 10 \cdot \text{ft} \right) \dots \\ + (\gamma_{EH} \cdot R_{EH\text{ftg}} \cdot 8.17 \cdot \text{ft}) \dots \\ + (\gamma_{LS} \cdot R_{LS\text{ftg}} \cdot 12.25 \cdot \text{ft}) \dots \\ + (\gamma_{TU} \cdot H_{\text{ufalltot}} \cdot 17.5 \cdot \text{ft})$$

$$M_{\text{lonftgstrV}} = 170.26 \frac{\text{K} \cdot \text{ft}}{\text{ft}}$$

The factored moment about the bridge longitudinal axis at the bottom of footing is:

$$M_{\text{traftgstrV}} = \gamma_{\text{WS}} \cdot \left(\frac{W_{\text{Ssupertrans0}}}{L_{\text{abut}}} \cdot 17.5 \cdot \text{ft} \right) \dots$$

$$+ \gamma_{\text{WS}} \cdot \left(\frac{W_{\text{Ssubtransend0}}}{L_{\text{abut}}} \cdot 10 \cdot \text{ft} \right) \dots$$

$$+ \gamma_{\text{WL}} \cdot \left(\frac{W_{\text{Ltrans0}}}{L_{\text{abut}}} \cdot 30.5 \text{ft} \right)$$

$$M_{\text{traftgstrV}} = 8.75 \frac{\text{K} \cdot \text{ft}}{\text{ft}}$$

Abutment bottom of footing Service I force effects for wind at 0 degrees and maximum live load:

The following load factors will be used to calculate the force effects for Service I:

$$\gamma_{\text{DC}} = 1.00$$

STable 3.4.1-2

$$\gamma_{\text{DW}} = 1.00$$

STable 3.4.1-2

$$\gamma_{\text{LL}} = 1.00$$

STable 3.4.1-1

$$\gamma_{\text{EH}} = 1.00$$

STable 3.4.1-2

$$\gamma_{\text{EV}} = 1.00$$

STable 3.4.1-2

$$\gamma_{\text{LS}} = 1.00$$

STable 3.4.1-1

$$\gamma_{\text{WS}} = 0.30 \quad \text{use wind at 0 degrees}$$

STable 3.4.1-1

$$\gamma_{\text{WL}} = 1.00$$

STable 3.4.1-1

$$\gamma_{\text{TU}} = 1.00 \quad \text{use contraction temperature force}$$

STable 3.4.1-1

The factored vertical force at the bottom of footing is:

$$F_{\text{vftgservi}} = (\gamma_{\text{DC}} \cdot D_{\text{Lbw}}) + (\gamma_{\text{DC}} \cdot D_{\text{Lstem}}) \dots$$

$$+ (\gamma_{\text{DC}} \cdot D_{\text{Lftg}}) + (\gamma_{\text{EV}} \cdot D_{\text{Learth}}) \dots$$

$$+ (\gamma_{\text{DC}} \cdot R_{\text{DCtot}}) + (\gamma_{\text{DW}} \cdot R_{\text{DWtot}}) \dots$$

$$+ (\gamma_{\text{LL}} \cdot R_{\text{LLmax1}})$$

$$F_{\text{vftgservi}} = 38.19 \frac{\text{K}}{\text{ft}}$$

The factored longitudinal shear force at the bottom of footing is:

$$F_{lonftgservl} = (\gamma_{EH} \cdot R_{EHftg}) + (\gamma_{LS} \cdot R_{LSftg}) \dots \\ + \left(\gamma_{WS} \cdot \frac{WS_{sublongend0}}{L_{abut}} \right) \dots \\ + (\gamma_{TU} \cdot H_{ufalltot})$$

$$F_{lonftgservl} = 12.96 \frac{K}{ft}$$

The factored transverse shear force at the bottom of footing is:

$$F_{traftgservl} = \gamma_{WS} \cdot \left(\frac{WS_{supertrans0}}{L_{abut}} \right) \dots \\ + \gamma_{WS} \cdot \left(\frac{WS_{subtransend0}}{L_{abut}} \right) \dots \\ + \gamma_{WL} \cdot \left(\frac{WL_{trans0}}{L_{abut}} \right)$$

$$F_{traftgservl} = 0.34 \frac{K}{ft}$$

The factored moment about the bridge transverse axis at the bottom of footing is:

$$M_{lonftgservl} = \left[\gamma_{DC} \cdot (DL_{bw}) \cdot (-0.177 \cdot ft) \right] \dots \\ + \left[\gamma_{DC} \cdot (DL_{stem}) \cdot 0.625 \cdot ft \right] \dots \\ + \left[\gamma_{EV} \cdot DL_{earth} \cdot (-3.125 \cdot ft) \right] \dots \\ + (\gamma_{DC} \cdot R_{DCtot} \cdot 1.75 \cdot ft) \dots \\ + (\gamma_{DW} \cdot R_{DWtot} \cdot 1.75 \cdot ft) \dots \\ + (\gamma_{LL} \cdot R_{LLmax1} \cdot 1.75 \cdot ft) \dots \\ + \left(\gamma_{WS} \cdot \frac{WS_{sublongend0}}{L_{abut}} \cdot 10 \cdot ft \right) \dots \\ + (\gamma_{EH} \cdot R_{EHftg} \cdot 8.17 \cdot ft) \dots \\ + (\gamma_{LS} \cdot R_{LSftg} \cdot 12.25 \cdot ft) \dots \\ + (\gamma_{TU} \cdot H_{ufalltot} \cdot 17.5 \cdot ft)$$

$$M_{lonftgservl} = 113.12 \frac{K \cdot ft}{ft}$$

The factored moment about the bridge longitudinal axis at the bottom of footing is:

$$M_{\text{traftgservI}} = \gamma_{\text{WS}} \cdot \left(\frac{WS_{\text{supertrans0}}}{L_{\text{abut}}} \cdot 17.5 \cdot \text{ft} \right) \dots$$

$$+ \gamma_{\text{WS}} \cdot \left(\frac{WS_{\text{subtransend0}}}{L_{\text{abut}}} \cdot 10 \cdot \text{ft} \right) \dots$$

$$+ \gamma_{\text{WL}} \cdot \left(\frac{WL_{\text{trans0}}}{L_{\text{abut}}} \cdot 30.5 \text{ft} \right)$$

$$M_{\text{traftgservI}} = 7.54 \frac{\text{K} \cdot \text{ft}}{\text{ft}}$$

Abutment bottom of footing Service I force effects for wind at 60 degrees and minimum live load:

The following load factors will be used to calculate the force effects for Service I:

$$\gamma_{\text{DC}} = 1.00$$

STable 3.4.1-2

$$\gamma_{\text{DW}} = 1.00$$

STable 3.4.1-2

$$\gamma_{\text{LL}} = 1.00$$

STable 3.4.1-1

$$\gamma_{\text{EH}} = 1.00$$

STable 3.4.1-2

$$\gamma_{\text{EV}} = 1.00$$

STable 3.4.1-2

$$\gamma_{\text{LS}} = 1.00$$

STable 3.4.1-1

$$\gamma_{\text{WS}} = 0.30$$

use for wind on stem end face for wind at 60 degrees

STable 3.4.1-1

$$\gamma_{\text{WL}} = 1.00$$

only applicable for wind angle of 0 degrees

STable 3.4.1-1

$$\gamma_{\text{TU}} = 1.00$$

use contraction temperature force

STable 3.4.1-1

The factored vertical force at the bottom of footing is:

$$F_{\text{vftgservImin}} = (\gamma_{\text{DC}} \cdot DL_{\text{bw}}) + (\gamma_{\text{DC}} \cdot DL_{\text{stem}}) \dots$$

$$+ (\gamma_{\text{DC}} \cdot DL_{\text{ftg}}) + (\gamma_{\text{EV}} \cdot DL_{\text{earth}}) \dots$$

$$+ (\gamma_{\text{DC}} \cdot R_{\text{DCtot}}) + (\gamma_{\text{DW}} \cdot R_{\text{DWtot}}) \dots$$

$$+ (\gamma_{\text{LL}} \cdot R_{\text{LLmin1}})$$

$$F_{\text{vftgservImin}} = 32.17 \frac{\text{K}}{\text{ft}}$$

The factored longitudinal shear force at the bottom of footing is:

$$F_{\text{longservlmin}} = (\gamma_{EH} \cdot R_{EH\text{ftg}}) + (\gamma_{LS} \cdot R_{LS\text{ftg}}) \dots \\ + \left(\gamma_{WS} \cdot \frac{WS_{\text{sublongend60}}}{L_{\text{abut}}} \right) \dots \\ + (\gamma_{TU} \cdot H_{\text{ufalltot}})$$

$$F_{\text{longservlmin}} = 12.97 \frac{\text{K}}{\text{ft}}$$

The factored transverse shear force at the bottom of footing is:

$$F_{\text{traftgservlmin}} = \gamma_{WS} \cdot \left(\frac{WS_{\text{supertrans60}}}{L_{\text{abut}}} \dots \right) \\ + \left(\frac{WS_{\text{subtransend60}}}{L_{\text{abut}}} \right)$$

$$F_{\text{traftgservlmin}} = 0.08 \frac{\text{K}}{\text{ft}}$$

The factored moment about the bridge transverse axis at the bottom of footing is:

$$M_{\text{longservlmin}} = [\gamma_{DC} \cdot (DL_{\text{bw}}) \cdot (-0.177 \cdot \text{ft})] \dots \\ + [\gamma_{DC} \cdot (DL_{\text{stem}}) \cdot 0.625 \cdot \text{ft}] \dots \\ + [\gamma_{EV} \cdot DL_{\text{earth}} \cdot (-3.125 \cdot \text{ft})] \dots \\ + (\gamma_{DC} \cdot R_{DC\text{tot}} \cdot 1.75 \cdot \text{ft}) \dots \\ + (\gamma_{DW} \cdot R_{DW\text{tot}} \cdot 1.75 \cdot \text{ft}) \dots \\ + (\gamma_{LL} \cdot R_{LL\text{max1}} \cdot 1.75 \cdot \text{ft}) \dots \\ + \left(\gamma_{WS} \cdot \frac{WS_{\text{sublongend60}}}{L_{\text{abut}}} \cdot 10 \cdot \text{ft} \right) \dots \\ + (\gamma_{EH} \cdot R_{EH\text{ftg}} \cdot 8.17 \cdot \text{ft}) \dots \\ + (\gamma_{LS} \cdot R_{LS\text{ftg}} \cdot 12.25 \cdot \text{ft}) \dots \\ + (\gamma_{TU} \cdot H_{\text{ufalltot}} \cdot 17.5 \cdot \text{ft})$$

$$M_{\text{longservlmin}} = 113.29 \frac{\text{K} \cdot \text{ft}}{\text{ft}}$$

The factored moment about the bridge longitudinal axis at the bottom of footing is:

$$M_{\text{traftgservlmin}} = \gamma_{\text{WS}} \cdot \left(\frac{W_{\text{Ssupertrans60}}}{L_{\text{abut}}} \cdot 17.5 \cdot \text{ft} \right) \dots$$

$$+ \gamma_{\text{WS}} \cdot \left(\frac{W_{\text{Ssublongend60}}}{L_{\text{abut}}} \cdot 10 \cdot \text{ft} \right)$$

$$M_{\text{traftgservlmin}} = 1.34 \frac{\text{K} \cdot \text{ft}}{\text{ft}}$$

The following table summarizes the combined forces at the bottom of footing that were calculated above. The forces were calculated at the center of the bottom of footing. The values shown in the table were multiplied by the abutment length to obtain the total effect. These forces are required for the geotechnical engineer to design the pile foundation. It should be noted that Design Step P was based on preliminary pile foundation design forces. In an actual design, the geotechnical engineer would need to revisit the pile foundation design calculations and update the results based on the final design bottom of footing forces given below.

Limit State	Vertical Force (K)	Long. Moment (K-ft)	Trans. Moment (K-ft)	Lateral Load (Long. Direction) (K)	Lateral Load (Trans. Direction) (K)
Strength I Max/Final	2426	8020	0	913	0
Strength I Min/Final	1366	4836	0	610	0
Strength III Max/Final	1815	6022	795	769	47
Service I Max/Final	1790	5302	353	607	16
Service I Min/Final	1508	5310	63	608	4

Table 7-6 Pile Foundation Design Forces

Design Step 7.8 - Check Stability and Safety Requirements

For abutment footings supported by piles, the stability and safety requirements deal with the amount of settlement that will occur to the substructure. For this design example, 1.5 inches of horizontal movement is acceptable and 0.5 inches of vertical settlement is acceptable. Design Step P verifies that less than the allowable horizontal and vertical displacements will take place using the pile size and layout described in Design Step P.

*S10.7.2.2 &
C11.5.2*

Design Step 7.9 - Design Abutment Backwall

It is recommended that Pier Design Step 8.8 is reviewed prior to beginning the abutment design. Design Step 8.8 reviews the design philosophy used to design the structural components of the pier and is applicable for the abutment as well.

Design for flexure:

Assume #5 bars:

$$\text{bar_diam} = 0.625\text{in}$$

$$\text{bar_area} = 0.31\text{in}^2$$

First, the minimum reinforcement requirements will be calculated. The tensile reinforcement provided must be enough to develop a factored flexural resistance at least equal to the lesser of 1.2 times the cracking strength or 1.33 times the factored moment from the applicable strength load combinations.

S5.7.3.3.2

The cracking strength is calculated by:

$$M_{cr} = \frac{f_r \cdot I_g}{y_t}$$

*SEquation
5.7.3.6.2-2*

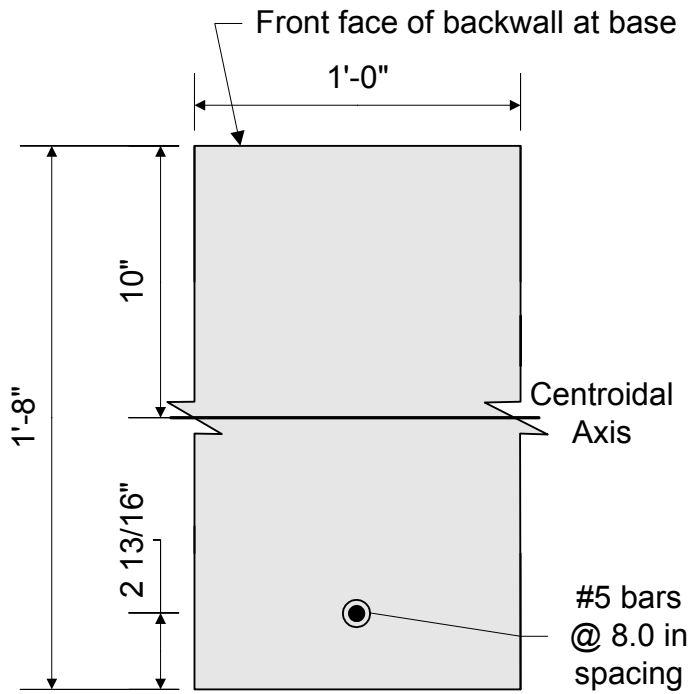

Figure 7-11 Abutment Backwall Cracking Moment Dimensions

$$f_r = 0.24 \cdot \sqrt{f'_c}$$

$$f_r = 0.48 \text{ ksi}$$

$$I_g = \frac{1}{12} (12 \text{ in}) (20 \text{ in})^3$$

$$I_g = 8000 \text{ in}^4$$

$$y_t = 10 \text{ in}$$

$$M_{Cr} = \frac{f_r I_g}{y_t}$$

$$M_{Cr} = 32.00 \frac{\text{K} \cdot \text{ft}}{\text{ft}}$$

$$1.2 \cdot M_{Cr} = 38.40 \frac{\text{K} \cdot \text{ft}}{\text{ft}}$$

S5.4.2.6

1.33 times the factored controlling backwall moment is:

$$M_{ubwmax} = 14.38 \frac{K \cdot ft}{ft}$$

$$1.33 \cdot M_{ubwmax} = 19.13 \frac{K \cdot ft}{ft}$$

Since 1.33 times the controlling factored backwall moment controls the minimum reinforcement requirements, use:

$$M_{ubwdes} = 1.33 \cdot M_{ubwmax}$$

$$M_{ubwdes} = 19.13 \frac{K \cdot ft}{ft}$$

Effective depth, d_e = total backwall thickness - cover - 1/2 bar diameter

$$t_{bw} = 20in \quad \text{backwall thickness}$$

$$d_e = t_{bw} - \text{Cover}_b - \frac{\text{bar_diam}}{2}$$

$$d_e = 17.19in$$

Solve for the required amount of reinforcing steel, as follows:

$$\phi_f = 0.90$$

$$b = 12in$$

$$Rn = \frac{M_{ubwdes} \cdot 12in}{(\phi_f \cdot b \cdot d_e^2)} \quad Rn = 0.072 \frac{K}{in^2}$$

$$\rho = 0.85 \left(\frac{f_c}{f_y} \right) \left[1.0 - \sqrt{1.0 - \frac{(2 \cdot Rn)}{(0.85 \cdot f_c)}} \right]$$

$$\rho = 0.00121$$

S5.5.4.2.1

Note: The above two equations are derived formulas that can be found in most reinforced concrete textbooks.

$$A_s = \rho \cdot \frac{b}{ft} \cdot d_e \quad A_s = 0.25 \frac{\text{in}^2}{ft}$$

$$\text{Required bar spacing} = \frac{\text{bar_area}}{A_s} = 14.9 \text{ in}$$

Use #5 bars @ bar_space = 9.0 in

$$A_s = \text{bar_area} \cdot \left(\frac{12 \text{ in}}{\text{bar_space}} \right) \quad A_s = 0.41 \text{ in}^2 \text{ per foot}$$

Once the bar size and spacing are known, the maximum reinforcement limit must be checked.

S5.7.3.3.1

$$T = A_s \cdot f_y \quad T = 24.80 \text{ K}$$

$$a = \frac{T}{0.85 \cdot f_c \cdot b} \quad a = 0.61 \text{ in}$$

$$\beta_1 = 0.85$$

S5.7.2.2

$$c = \frac{a}{\beta_1} \quad c = 0.72 \text{ in}$$

S5.7.2.2

$$\frac{c}{d_e} = 0.04 \quad \text{where} \quad \frac{c}{d_e} \leq 0.42$$

S5.7.3.3.1

$$0.04 \leq 0.42 \quad \text{OK}$$

The backwall flexure reinforcement bar spacing was set at 9.0 inches so that it could lap with the flexure reinforcement in the stem. Originally, the backwall bars were set at 12.0 inches. After completing the stem design, the backwall design was updated to match the stem flexure reinforcement bar spacing.

Check crack control:

The control of cracking by distribution of reinforcement must be checked.

S5.7.3.4

Since this design example assumes that the backwall will be exposed to deicing salts, use:

$$Z = 130 \frac{\text{K}}{\text{in}}$$

Thickness of clear cover used to compute d_c should not be greater than 2 inches:

$$d_c = 2.5\text{in} + \frac{\text{bar_diam}}{2}$$

$$d_c = 2.81\text{in}$$

use $d_c = 2.0\text{in} + \frac{\text{bar_diam}}{2}$

$$d_c = 2.31\text{in}$$

Concrete area with centroid the same as transverse bar and bounded by the cross section and line parallel to neutral axis:

$$A_c = 2 \cdot (d_c) \cdot \text{bar_space}$$

$$A_c = 41.63\text{in}^2$$

The equation that gives the allowable reinforcement service load stress for crack control is:

$$f_{sa} = \frac{Z}{(d_c \cdot A_c)^{\frac{1}{3}}} \quad \text{where} \quad f_{sa} \leq 0.6 \cdot f_y$$

$$f_{sa} = 28.37\text{ksi}$$

$$0.6f_y = 36.00\text{ksi}$$

Use $f_{sa} = 28.37\text{ksi}$

$$E_s = 29000\text{ksi}$$

S5.4.3.2

$$E_c = 3640\text{ksi}$$

S5.4.2.4

$$n = \frac{E_s}{E_c} \quad n = 7.97 \quad \text{Use} \quad n = 8$$

Service backwall total load moment:

$$M_{ubw\text{servl}} = 8.51 \frac{\text{K}\cdot\text{ft}}{\text{ft}}$$

To solve for the actual stress in the reinforcement, the transformed moment of inertia and the distance from the neutral axis to the centroid of the reinforcement must be computed:

$$d_e = 17.19 \text{ in} \quad A_s = 0.413 \frac{\text{in}^2}{\text{ft}} \quad n = 8$$

$$\rho = \frac{A_s}{\frac{b}{\text{ft}} \cdot d_e} \quad \rho = 0.002$$

$$k = \sqrt{(\rho \cdot n)^2 + (2 \cdot \rho \cdot n)} - \rho \cdot n$$

$$k = 0.164$$

$$k \cdot d_e = 2.81 \text{ in}$$

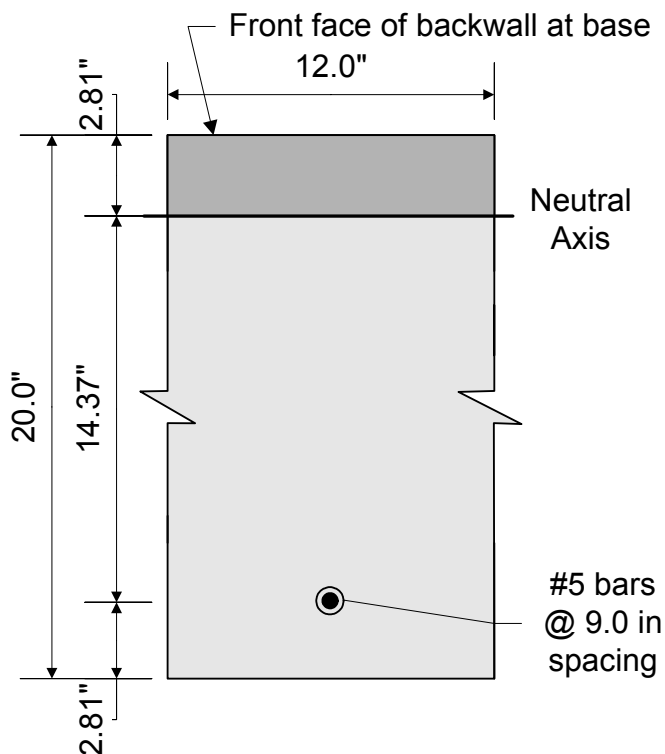

Figure 7-12 Abutment Backwall Crack Control Check

Once $k d_e$ is known, the transformed moment of inertia can be computed:

$$d_e = 17.19 \text{ in}$$

$$A_s = 0.413 \frac{\text{in}^2}{\text{ft}}$$

$$I_t = \frac{1}{3} \cdot \left(12 \frac{\text{in}}{\text{ft}} \right) \cdot (k \cdot d_e)^3 + n \cdot A_s \cdot (d_e - k \cdot d_e)^2$$

$$I_t = 771.73 \frac{\text{in}^4}{\text{ft}}$$

Now, the actual stress in the reinforcement can be computed:

$$y = d_e - k \cdot d_e \quad y = 14.37 \text{ in}$$

$$f_s = \frac{n \cdot \left(M_{ubw\text{servl}} \cdot 12 \frac{\text{in}}{\text{ft}} \cdot y \right)}{I_t}$$

$$f_s = 15.22 \text{ ksi} \quad f_{sa} > f_s \quad \text{OK}$$

Design for shear:

The factored longitudinal shear force at the base of the backwall is:

$$V_{ubw\text{max}} = 2.91 \frac{\text{K}}{\text{ft}}$$

The nominal shear resistance is the lesser of:

$$V_{n1} = V_c + V_s \blacksquare$$

or

$$V_{n2} = 0.25 \cdot f_c \cdot b_v \cdot d_v \blacksquare$$

where:

$$V_c = 0.0316 \cdot \beta \cdot \sqrt{f_c} \cdot b_v \cdot d_v \blacksquare$$

and

$$V_s = \frac{A_v \cdot f_y \cdot d_v \cdot (\cot\theta + \cot\alpha) \cdot \sin\alpha \blacksquare}{s}$$

neglect for this abutment design

S5.8.3.3

Before the nominal shear resistance can be calculated, all the variables used in the above equations need to be defined.

$$\beta = 2.0$$

S5.8.3.4.1

$$b_v = 12 \text{ in}$$

$$d_v = \max\left(d_e - \frac{a}{2}, 0.9 \cdot d_e, 0.72 \cdot h\right)$$

S5.8.2.9

where:

$$h = 20 \text{ in}$$

$$d_v = 16.80 \text{ in}$$

Now, V_{n1} and V_{n2} can be calculated:

$$\text{For } f_c = 4.0 \text{ ksi}$$

$$V_{n1} = 0.0316 \cdot \beta \cdot \sqrt{f_c} \cdot b_v \cdot d_v$$

$$V_{n1} = 25.48 \frac{\text{K}}{\text{ft}}$$

$$V_{n2} = 0.25 \cdot f_c \cdot b_v \cdot d_v$$

$$V_{n2} = 201.60 \frac{\text{K}}{\text{ft}}$$

$$\text{Use: } V_n = 25.48 \frac{\text{K}}{\text{ft}}$$

The factored shear resistance is then:

$$\phi_v = 0.90$$

S5.5.4.2.1

$$V_r = \phi_v \cdot V_n$$

$$V_r = 22.93 \frac{\text{K}}{\text{ft}}$$

$$V_r > V_{ubwmax} \quad \text{OK}$$

Shrinkage and temperature reinforcement:

S5.10.8

For members less than 48.0 inches thick, the area of reinforcement in each direction shall not be spaced greater than 12.0 inches and satisfy the lesser of:

S5.10.8.2

$$A_s \geq 0.11 \frac{A_g}{f_y}$$

or

$$\Sigma A_b = 0.0015 A_g$$

$$A_g = (20 \cdot \text{in}) \cdot \left(12 \cdot \frac{\text{in}}{\text{ft}}\right) \quad A_g = 240.0 \frac{\text{in}^2}{\text{ft}}$$

$$f_y = 60 \text{ ksi}$$

$$0.11 \cdot \frac{A_g}{f_y} = 0.44 \frac{\text{in}^2}{\text{ft}}$$

or

$$0.0015 A_g = 0.36 \frac{\text{in}^2}{\text{ft}}$$

A_s must be greater than or equal to $0.36 \text{ in}^2/\text{ft}$

The above steel must be distributed equally on both faces of the backwall.

Try 1 horizontal # 4 bar for each face of the backwall at 12.0 inch spacing:

$$\text{bar_diam} = 0.500 \text{ in}$$

$$\text{bar_area} = 0.20 \text{ in}^2$$

$$A_s = 2 \cdot \frac{\text{bar_area}}{\text{ft}} \quad A_s = 0.40 \frac{\text{in}^2}{\text{ft}}$$

$$0.40 \frac{\text{in}^2}{\text{ft}} \geq 0.36 \frac{\text{in}^2}{\text{ft}} \quad \text{OK}$$

Based on the backwall design, #5 bars at 9.0 inch spacing will be used for the back face flexure reinforcement. The same bar size and spacing will be used for the front face vertical reinforcement. The horizontal temperature and shrinkage reinforcement will consist of #4 bars at 12.0 inch spacing for the front and back faces.

Design Step 7.10 - Design Abutment StemDesign for flexure:

Assume #9 bars:

$$\text{bar_diam} = 1.128\text{in}$$

$$\text{bar_area} = 1.00\text{in}^2$$

$$f_y = 60\text{ksi}$$

As with the backwall, the minimum reinforcement requirements will be calculated for the stem. The tensile reinforcement provided must be enough to develop a factored flexural resistance at least equal to the lesser of 1.2 times the cracking strength or 1.33 times the factored moment from the applicable strength load combinations.

The cracking strength is calculated by:

$$M_{cr} = \frac{f_r \cdot I_g}{y_t}$$

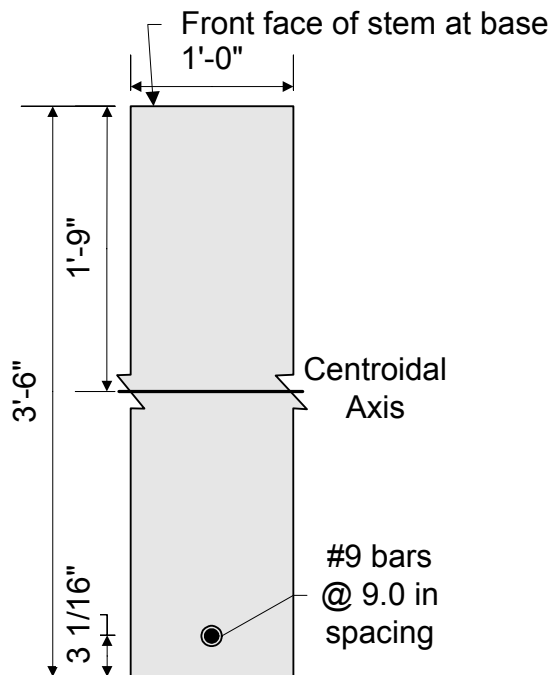

Figure 7-13 Abutment stem Cracking Moment Dimensions

S5.7.3.3.2

SEquation
5.7.3.6.2-2

$$f_r = 0.24 \cdot \sqrt{f'_c}$$

$$f_r = 0.48 \text{ksi}$$

$$I_g = \frac{1}{12} (12 \text{in}) (42 \text{in})^3$$

$$I_g = 74088 \text{in}^4$$

$$y_t = 21 \text{in}$$

$$M_{Cr} = \frac{f_r I_g}{y_t}$$

$$M_{Cr} = 141.12 \frac{\text{K} \cdot \text{ft}}{\text{ft}}$$

$$1.2 \cdot M_{Cr} = 169.34 \frac{\text{K} \cdot \text{ft}}{\text{ft}}$$

1.33 times the factored controlling stem moment is:

$$M_{ustemmax} = 156.61 \frac{\text{K} \cdot \text{ft}}{\text{ft}}$$

$$1.33 \cdot M_{ustemmax} = 208.29 \frac{\text{K} \cdot \text{ft}}{\text{ft}}$$

1.2 times the cracking moment controls the minimum reinforcement requirements. 1.2 times the cracking moment is also greater than the controlling applied factored moment, therefore, use 1.2 times the cracking moment for design.

$$M_{ustemdes} = 1.2 \cdot M_{Cr}$$

$$M_{ustemdes} = 169.34 \frac{\text{K} \cdot \text{ft}}{\text{ft}}$$

Effective depth, d_e = total backwall thickness - cover - 1/2 bar diameter

$$\text{thickness of stem: } t_{stem} = 42 \text{in}$$

$$d_e = t_{stem} - \text{Cover}_s - \frac{\text{bar_diam}}{2}$$

$$d_e = 38.94 \text{in}$$

S5.4.2.6

Solve for the required amount of reinforcing steel, as follows:

$$\phi_f = 0.90$$

$$b = 12\text{in}$$

$$f_c = 4.0\text{ksi}$$

$$R_n = \frac{M_{\text{ustemdes}} \cdot 12\text{in}}{(\phi_f \cdot b \cdot d_e^2)} \quad R_n = 0.124 \frac{\text{K}}{\text{in}^2}$$

$$\rho = 0.85 \left(\frac{f_c}{f_y} \right) \left[1.0 - \sqrt{1.0 - \frac{(2 \cdot R_n)}{(0.85 \cdot f_c)}} \right] \quad \rho = 0.00211$$

Note: The above two equations are derived formulas that can be found in most reinforced concrete textbooks.

$$A_s = \rho \cdot \frac{b}{\text{ft}} \cdot d_e \quad A_s = 0.98 \frac{\text{in}^2}{\text{ft}}$$

$$\text{Required bar spacing} = \frac{\text{bar_area}}{A_s} = 12.2\text{in}$$

Use #9 bars @ $\text{bar_space} = 9.0\text{in}$

$$A_s = \text{bar_area} \cdot \left(\frac{12\text{in}}{\text{bar_space}} \right) \quad A_s = 1.33\text{in}^2 \text{ per foot}$$

Now, the maximum reinforcement limit must be checked. This check could be skipped since the calculated factored design moment is less than 1.2 times the cracking moment.

$$T = A_s \cdot f_y \quad T = 80.00\text{K}$$

$$a = \frac{T}{0.85 \cdot f_c \cdot b} \quad a = 1.96\text{in}$$

$$\beta_1 = 0.85$$

$$c = \frac{a}{\beta_1} \quad c = 2.31\text{in}$$

$$\frac{c}{d_e} = 0.06 \quad \text{where} \quad \frac{c}{d_e} \leq 0.42$$

$$0.06 \leq 0.42 \quad \text{OK}$$

S5.5.4.2.1

S5.7.3.3.1

S5.7.2.2

S5.7.2.2

S5.7.3.3.1

Check crack control:

The control of cracking by distribution of reinforcement must be checked.

S5.7.3.4

Since this design example assumes that the abutment stem will be exposed to deicing salts, use:

$$Z = 130 \frac{\text{K}}{\text{in}}$$

Thickness of clear cover used to compute d_c should not be greater than 2 inches:

$$d_c = 2.5\text{in} + \frac{\text{bar_diam}}{2}$$

$$d_c = 3.06\text{in}$$

use $d_c = 2.0\text{in} + \frac{\text{bar_diam}}{2}$

$$d_c = 2.56\text{in}$$

Concrete area with centroid the same as transverse bar and bounded by the cross section and line parallel to neutral axis:

$$A_c = 2 \cdot (d_c) \cdot \text{bar_space}$$

$$A_c = 46.15\text{in}^2$$

The equation that gives the allowable reinforcement service load stress for crack control is:

$$f_{sa} = \frac{Z}{(d_c \cdot A_c)^{\frac{1}{3}}} \quad \text{where} \quad f_{sa} \leq 0.6 \cdot f_y$$

$$f_{sa} = 26.48\text{ksi}$$

$$0.6f_y = 36.00\text{ksi}$$

Use $f_{sa} = 26.48\text{ksi}$

$$E_s = 29000\text{ksi}$$

S5.4.3.2

$$E_c = 3640\text{ksi}$$

S5.4.2.4

$$n = \frac{E_s}{E_c} \quad n = 7.97 \quad \text{Use} \quad n = 8$$

Stem factored service moment:

$$M_{ustemservl} = 105.82 \frac{\text{K}\cdot\text{ft}}{\text{ft}}$$

To solve for the actual stress in the reinforcement, the transformed moment of inertia and the distance from the neutral axis to the centroid of the reinforcement must be computed:

$$d_e = 38.94 \text{ in} \quad A_s = 1.33 \frac{\text{in}^2}{\text{ft}} \quad n = 8$$

$$\rho = \frac{A_s}{\frac{b}{\text{ft}} \cdot d_e} \quad \rho = 0.00285$$

$$k = \sqrt{(\rho \cdot n)^2 + (2 \cdot \rho \cdot n)} - \rho \cdot n$$

$$k = 0.192$$

$$k \cdot d_e = 7.47 \text{ in}$$

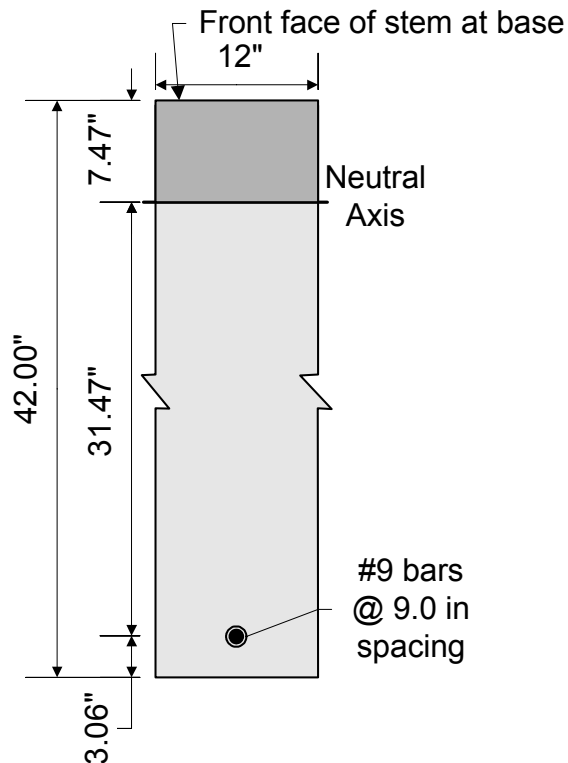

Figure 7-14 Abutment Stem Crack Control Check

Once kd_e is known, the transformed moment of inertia can be computed:

$$d_e = 38.94 \text{ in}$$

$$A_s = 1.330 \frac{\text{in}^2}{\text{ft}}$$

$$I_t = \frac{1}{3} \cdot \left(12 \frac{\text{in}}{\text{ft}} \right) \cdot (k \cdot d_e)^3 + n \cdot A_s \cdot (d_e - k \cdot d_e)^2$$

$$I_t = 12202.09 \frac{\text{in}^4}{\text{ft}}$$

Now, the actual stress in the reinforcement can be computed:

$$y = d_e - k \cdot d_e \quad y = 31.47 \text{ in}$$

$$f_s = \frac{n \cdot \left(M_{\text{ustemservl}} \cdot 12 \frac{\text{in}}{\text{ft}} \cdot y \right)}{I_t}$$

$$f_s = 26.20 \text{ ksi} \quad f_{sa} > f_s \quad \text{OK}$$

Design for shear:

The factored longitudinal shear force at the base of the stem is:

$$V_{\text{ustemmax}} = 16.03 \frac{\text{K}}{\text{ft}}$$

The nominal shear resistance is the lesser of:

$$V_{n1} = V_c + V_s$$

or

$$V_{n2} = 0.25 \cdot f_c \cdot b_v \cdot d_v$$

where:

$$V_c = 0.0316 \cdot \beta \cdot \sqrt{f_c} \cdot b_v \cdot d_v$$

and

$$V_s = \frac{A_v \cdot f_y \cdot d_v \cdot (\cot\theta + \cot\alpha) \cdot \sin\alpha}{s}$$

neglect for this abutment design

S5.8.3.3

Before the nominal shear resistance can be calculated, all the variables used in the above equations need to be defined.

$$\beta = 2.0$$

S5.8.3.4.1

$$b_v = 12 \text{ in}$$

$$d_v = \max\left(d_e - \frac{a}{2}, 0.9 \cdot d_e, 0.72 \cdot h\right)$$

S5.8.2.9

where:

$$h = 42 \text{ in}$$

$$d_v = 38.2 \text{ in}$$

Now, V_{n1} and V_{n2} can be calculated:

$$\text{For } f_c = 4.0 \text{ ksi}$$

$$V_{n1} = 0.0316 \cdot \beta \cdot \sqrt{f_c} \cdot b_v \cdot d_v$$

$$V_{n1} = 57.94 \frac{\text{K}}{\text{ft}}$$

$$V_{n2} = 0.25 \cdot f_c \cdot b_v \cdot d_v$$

$$V_{n2} = 458.40 \frac{\text{K}}{\text{ft}}$$

$$\text{use } V_n = 57.94 \frac{\text{K}}{\text{ft}}$$

The factored shear resistance is then:

$$\phi_v = 0.90$$

S5.5.4.2.1

$$V_r = \phi_v \cdot V_n$$

$$V_r = 52.15 \frac{\text{K}}{\text{ft}}$$

$$V_r > V_{ustemmax} \quad \text{OK}$$

Shrinkage and temperature reinforcement:

S5.10.8

For members less than 48.0 inches thick, the area of reinforcement in each direction shall not be spaced greater than 12.0 inches and satisfy the lesser of:

S5.10.8.2

$$A_s \geq 0.11 \frac{A_g}{f_y}$$

or

$$\Sigma A_b = 0.0015 A_g$$

$$A_g = (42 \cdot \text{in}) \cdot \left(12 \cdot \frac{\text{in}}{\text{ft}}\right) \quad A_g = 504.0 \frac{\text{in}^2}{\text{ft}}$$

$$f_y = 60 \text{ ksi}$$

$$0.11 \cdot \frac{A_g}{f_y} = 0.92 \frac{\text{in}^2}{\text{ft}}$$

or

$$0.0015 A_g = 0.76 \frac{\text{in}^2}{\text{ft}}$$

A_s must be greater than or equal to $0.76 \text{ in}^2/\text{ft}$

The above steel must be distributed equally on both faces of the stem.

Try 1 horizontal # 5 bar for each face of the stem at 9.0 inch spacing:

$$\text{bar_diam} = 0.625 \text{ in}$$

$$\text{bar_area} = 0.31 \text{ in}^2$$

$$A_s = 2 \cdot \frac{\text{bar_area} \cdot \left(\frac{12 \text{ in}}{9 \text{ in}}\right)}{\text{ft}} \quad A_s = 0.83 \frac{\text{in}^2}{\text{ft}}$$

$$0.83 \frac{\text{in}^2}{\text{ft}} \geq 0.76 \frac{\text{in}^2}{\text{ft}} \quad \text{OK}$$

Based on the abutment stem design, #9 bars at 9.0 inch spacing will be used for the back face flexure reinforcement. The same bar size and spacing will be used for the front face vertical reinforcement to reduce design steps. The horizontal temperature and shrinkage reinforcement will consist of #5 bars at 9.0 inch spacing for the front and back faces.

Design Step 7.11 - Design Abutment Footing

The abutment footing is designed for flexure in the heel and toe, one-way and two-way shear action, and the control of cracking by the distribution of reinforcement. For footings supported by pile foundations, the footing and pile foundation designs are interdependent and should be designed concurrently to be more efficient. Refer to Design Step P for the pile foundation design.

The following figures show the assumed footing dimensions and pile locations within the footing.

S5.13.3

S5.7.3.4

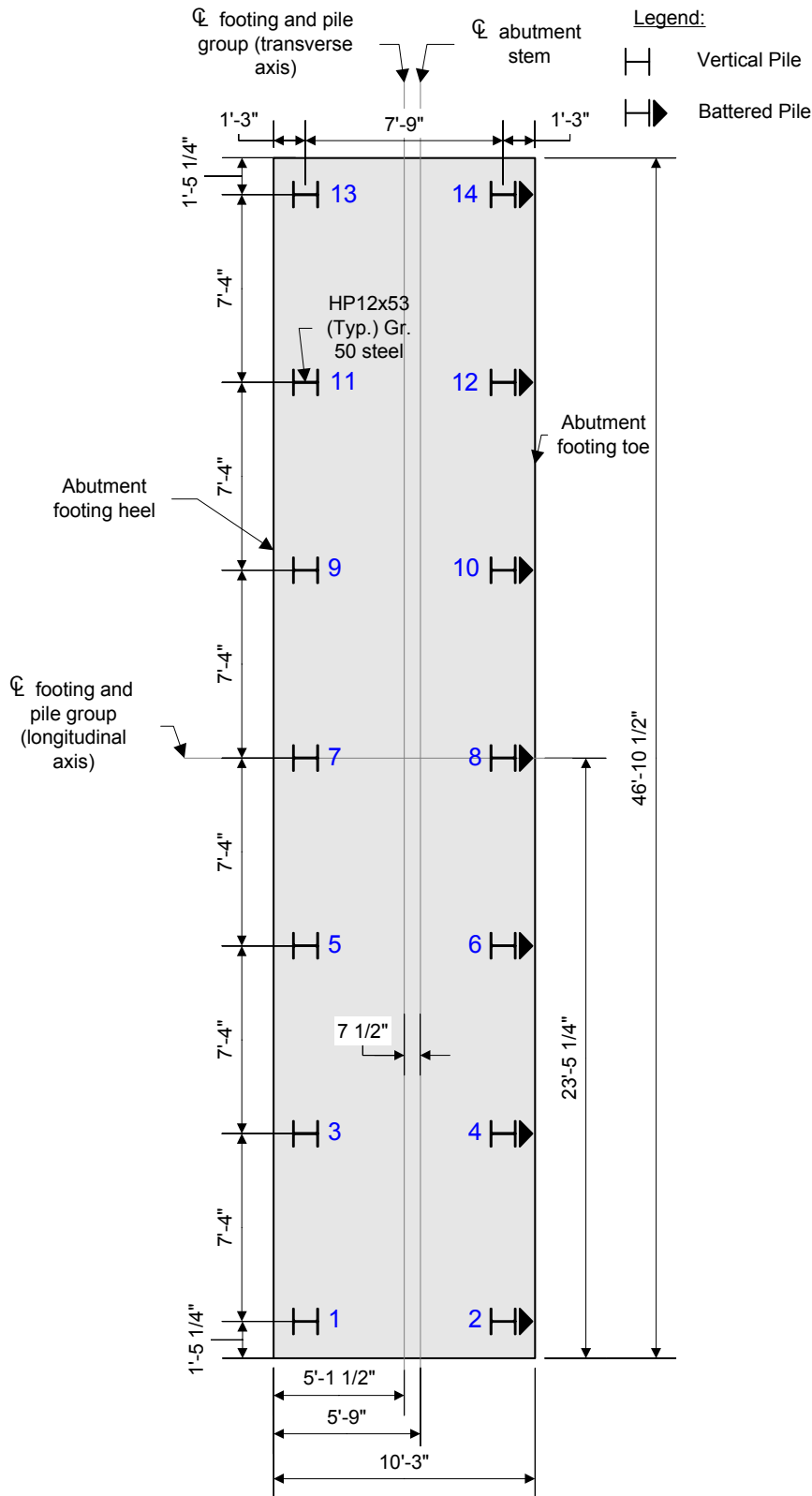

Figure 7-15 Abutment Footing and Pile Foundation Plan View

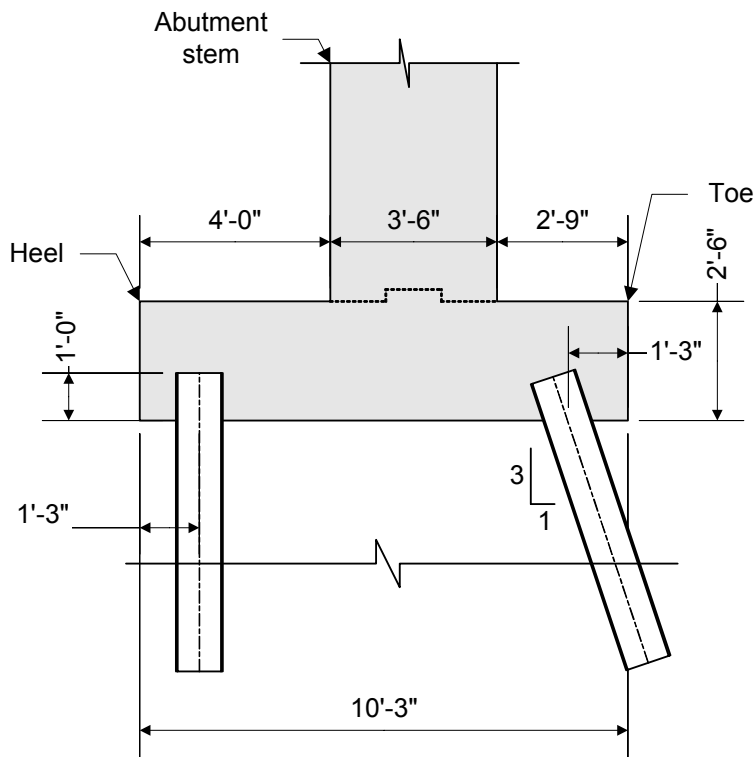

Figure 7-16 Abutment Footing and Pile Foundation Elevation View

Design for flexure:

The flexure reinforcement must be designed at two critical sections for abutment footings. The two sections include the back and front face of the stem. The moments at the abutment faces are calculated from the pile reactions.

S5.13.3.4

For the abutment front face, the following moment arm will be used:

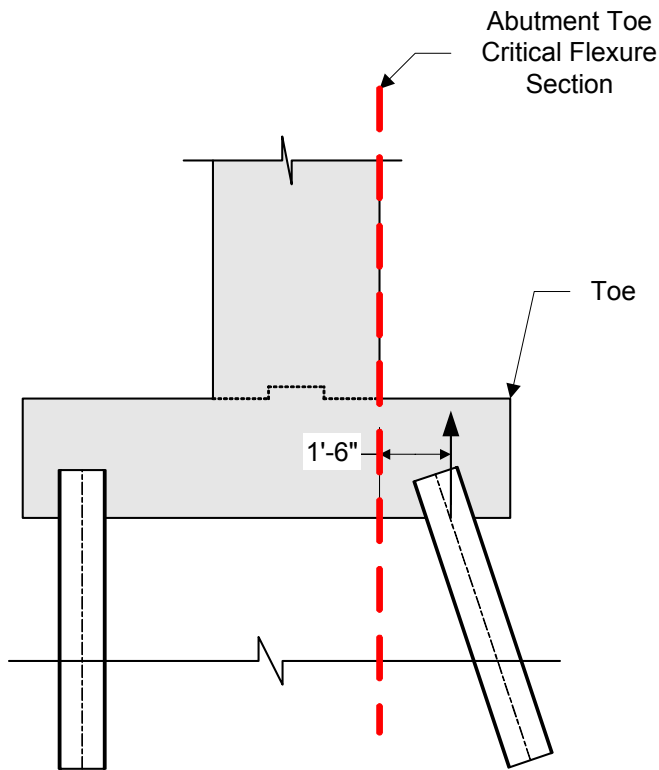

Figure 7-17 Abutment Toe Critical Flexure Section

The controlling moment on the critical section occurs when the pile loads on the front row of piles are maximized. From Tables P-17 to P-20, the front row pile loads are maximized for Strength I using the maximum load factors at the final construction condition and are summarized below.

$$P_2 = 315.3\text{K} \quad P_{10} = 335.4\text{K}$$

$$P_4 = 330.5\text{K} \quad P_{12} = 330.7\text{K}$$

$$P_6 = 336.1\text{K} \quad P_{14} = 315.6\text{K}$$

$$P_8 = 339.9\text{K}$$

Since the above pile loads are already factored, no load factors need to be applied and the total factored moment is as follows:

$$M_{\text{utoe}} = 1.5\text{ft} \cdot (P_2 + P_4 + P_6 + P_8 + P_{10} + P_{12} + P_{14})$$

$$M_{\text{utoe}} = 3455.25 \text{K} \cdot \text{ft}$$

The moment on a per foot basis is then:

$$M_{\text{utoeft}} = \frac{M_{\text{utoe}}}{L_{\text{abut}}}$$

$$M_{\text{utoeft}} = 73.71 \text{ K} \cdot \frac{\text{ft}}{\text{ft}}$$

Once the maximum moment at the critical section is known, the same procedure that was used for the backwall and stem to calculate the flexure reinforcement must be followed. The footing toe flexure reinforcement is located longitudinally in the bottom of the footing since the bottom of footing is in tension at the critical toe section. These bars will extend from the back of the heel to the front of the toe taking into account the clear cover:

Assume #8 bars:

$$\text{bar_diam} = 1.000 \text{ in}$$

$$\text{bar_area} = 0.79 \text{ in}^2$$

$$f_y = 60 \text{ ksi}$$

The footing toe critical section minimum tensile reinforcement requirements will be calculated. The tensile reinforcement provided must be enough to develop a factored flexural resistance at least equal to the lesser of 1.2 times the cracking strength or 1.33 times the factored moment from the applicable strength load combinations.

The cracking strength is calculated by:

$$M_{\text{cr}} = \frac{f_r \cdot I_g}{y_t}$$

S5.7.3.3.2

SEquation
5.7.3.6.2-2

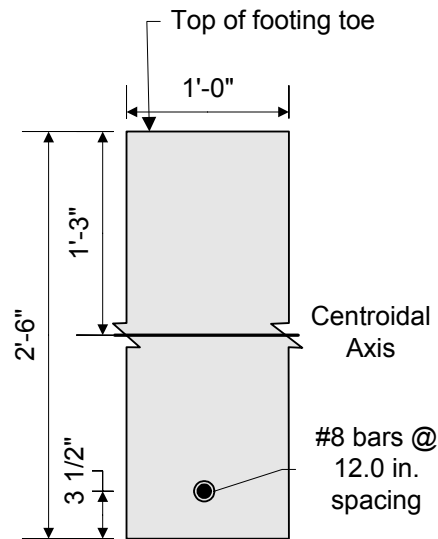

Figure 7-18 Abutment Footing Toe Cracking Moment Dimensions

$$f_r = 0.24 \cdot \sqrt{f'_c}$$

$$f_r = 0.48 \text{ ksi}$$

$$I_g = \frac{1}{12} (12 \text{ in}) (30 \text{ in})^3$$

$$I_g = 27000 \text{ in}^4$$

$$y_t = 15 \text{ in}$$

$$M_{Cr} = \frac{f_r I_g}{y_t}$$

$$M_{Cr} = 72.00 \frac{\text{K} \cdot \text{ft}}{\text{ft}}$$

$$1.2 \cdot M_{Cr} = 86.40 \frac{\text{K} \cdot \text{ft}}{\text{ft}}$$

1.33 times the factored controlling stem moment is:

$$M_{\text{utoeft}} = 73.71 \frac{\text{K} \cdot \text{ft}}{\text{ft}}$$

$$1.33 \cdot M_{\text{utoeft}} = 98.04 \frac{\text{K} \cdot \text{ft}}{\text{ft}}$$

S5.4.2.6

1.2 times the cracking moment controls the minimum reinforcement requirements. 1.2 times the cracking moment is also greater than the factored footing toe moment. Therefore, use 1.2 times the cracking moment to design the toe flexure reinforcement.

$$M_{\text{uffttoedes}} = 1.2 \cdot M_{\text{cr}}$$

$$M_{\text{uffttoedes}} = 86.40 \frac{\text{K}\cdot\text{ft}}{\text{ft}}$$

Effective depth, d_e = total footing thickness - cover - 1/2 bar diameter

$$\text{thickness of footing: } t_{\text{ftg}} = 30\text{in}$$

$$\text{Cover}_{\text{fb}} = 3.00\text{in}$$

$$d_e = t_{\text{ftg}} - \text{Cover}_{\text{fb}} - \frac{\text{bar_diam}}{2}$$

$$d_e = 26.50\text{in}$$

Solve for the required amount of reinforcing steel, as follows:

$$\phi_f = 0.90$$

$$b = 12\text{in}$$

$$f_c = 4.0\text{ksi}$$

$$R_n = \frac{M_{\text{uffttoedes}} \cdot 12\text{in}}{(\phi_f \cdot b \cdot d_e^2)} \quad R_n = 0.137 \frac{\text{K}}{\text{in}^2}$$

$$\rho = 0.85 \left(\frac{f_c}{f_y} \right) \left[1.0 - \sqrt{1.0 - \frac{(2 \cdot R_n)}{(0.85 \cdot f_c)}} \right]$$

$$\rho = 0.00233$$

Note: The above two equations are derived formulas that can be found in most reinforced concrete textbooks.

$$A_s = \rho \cdot \frac{b}{\text{ft}} \cdot d_e \quad A_s = 0.74 \frac{\text{in}^2}{\text{ft}}$$

$$\text{Required bar spacing} = \frac{\text{bar_area}}{A_s} = 12.8\text{in}$$

S5.5.4.2.1

Use #8 bars @ $\text{bar_space} = 12.0\text{in}$

$$A_s = \text{bar_area} \cdot \left(\frac{12\text{in}}{\text{bar_space}} \right) \quad A_s = 0.79\text{in}^2 \text{ per foot}$$

Once the bar size and spacing are known, the maximum reinforcement limit must be checked.

S5.7.3.3.1

$$T = A_s \cdot f_y \quad T = 47.40\text{K}$$

$$a = \frac{T}{0.85 \cdot f_c \cdot b} \quad a = 1.16\text{in}$$

$$\beta_1 = 0.85$$

S5.7.2.2

$$c = \frac{a}{\beta_1} \quad c = 1.37\text{in}$$

S5.7.2.2

$$\frac{c}{d_e} = 0.05 \quad \text{where} \quad \frac{c}{d_e} \leq 0.42$$

S5.7.3.3.1

$$0.05 \leq 0.42 \quad \text{OK}$$

Check crack control:

The control of cracking by distribution of reinforcement must be checked for the abutment toe.

S5.7.3.4

Since the footing is buried, moderate exposure will be assumed, use:

$$Z = 170 \frac{\text{K}}{\text{in}}$$

Thickness of clear cover used to compute d_c should not be greater than 2 inches:

$$d_c = 3.0\text{in} + \frac{\text{bar_diam}}{2}$$

$$d_c = 3.50\text{in}$$

$$\text{use } d_c = 2.0\text{in} + \frac{\text{bar_diam}}{2}$$

$$d_c = 2.50\text{in}$$

Concrete area with centroid the same as transverse bar and bounded by the cross section and line parallel to neutral axis:

$$A_c = 2 \cdot (d_c) \cdot \text{bar_space}$$

$$A_c = 60.00\text{in}^2$$

The equation that gives the allowable reinforcement service load stress for crack control is:

$$f_{sa} = \frac{Z}{(d_c \cdot A_c)^{\frac{1}{3}}} \quad \text{where} \quad f_{sa} \leq 0.6 \cdot f_y$$

$$f_{sa} = 32.00 \text{ ksi} \quad 0.6f_y = 36.00 \text{ ksi}$$

$$\text{Use } f_{sa} = 32.00 \text{ ksi}$$

$$E_s = 29000 \text{ ksi}$$

S5.4.3.2

$$E_c = 3640 \text{ ksi}$$

S5.4.2.4

$$n = \frac{E_s}{E_c} \quad n = 7.97 \quad \text{Use } n = 8$$

The pile loads used to compute the controlling footing toe moment for the Service I limit state are again taken from Design Step P, Tables P-17 through P-20.

$$P_2 = 221.5 \text{ K} \quad P_{10} = 234.9 \text{ K}$$

$$P_4 = 232.2 \text{ K} \quad P_{12} = 230.8 \text{ K}$$

$$P_6 = 235.9 \text{ K} \quad P_{14} = 219.3 \text{ K}$$

$$P_8 = 238.6 \text{ K}$$

The footing toe service moment is then calculated by:

$$M_{\text{toeservI}} = 1.5 \text{ ft} \cdot (P_2 + P_4 + P_6 + P_8 + P_{10} + P_{12} + P_{14})$$

$$M_{\text{toeservI}} = 2419.80 \text{ K} \cdot \text{ft}$$

The moment on a per foot basis is then:

$$M_{\text{toeftservI}} = \frac{M_{\text{toeservI}}}{L_{\text{abut}}}$$

$$M_{\text{toeftservI}} = 51.62 \frac{\text{K} \cdot \text{ft}}{\text{ft}}$$

To solve for the actual stress in the reinforcement, the transformed moment of inertia and the distance from the neutral axis to the centroid of the reinforcement must be computed:

$$d_e = 26.50 \text{ in} \quad A_s = .79 \frac{\text{in}^2}{\text{ft}} \quad n = 8$$

$$\rho = \frac{A_s}{\frac{b}{\text{ft}} \cdot d_e} \quad \rho = 0.00248$$

$$k = \sqrt{(\rho \cdot n)^2 + (2 \cdot \rho \cdot n)} - \rho \cdot n$$

$$k = 0.180$$

$$k \cdot d_e = 4.78 \text{ in}$$

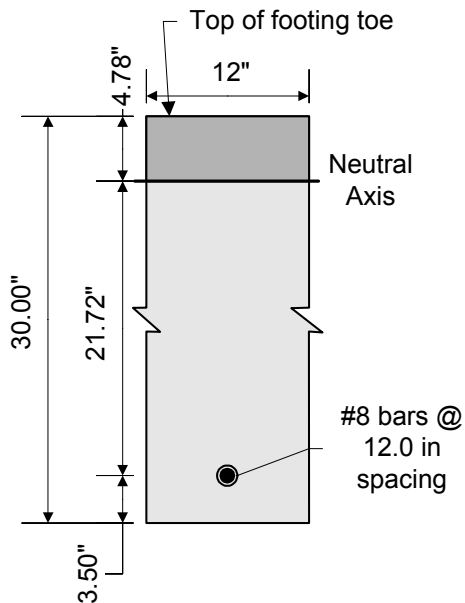

Figure 7-19 Abutment Footing Toe Crack Control Check

Once kd_e is known, the transformed moment of inertia can be computed:

$$d_e = 26.50 \text{ in}$$

$$A_s = 0.790 \frac{\text{in}^2}{\text{ft}}$$

$$I_t = \frac{1}{3} \cdot \left(12 \frac{\text{in}}{\text{ft}}\right) \cdot (k \cdot d_e)^3 + n \cdot A_s \cdot (d_e - k \cdot d_e)^2$$

$$I_t = 3418.37 \frac{\text{in}^4}{\text{ft}}$$

Now, the actual stress in the reinforcement can be computed:

$$y = d_e - k \cdot d_e \quad y = 21.72 \text{ in}$$

$$f_s = \frac{n \cdot \left(M_{\text{utoeftservl}} \cdot 12 \frac{\text{in}}{\text{ft}} \cdot y \right)}{I_t}$$

$$f_s = 31.48 \text{ ksi} \quad f_{sa} > f_s \quad \text{OK}$$

For the abutment back face flexure design, the following moment arm will be used:

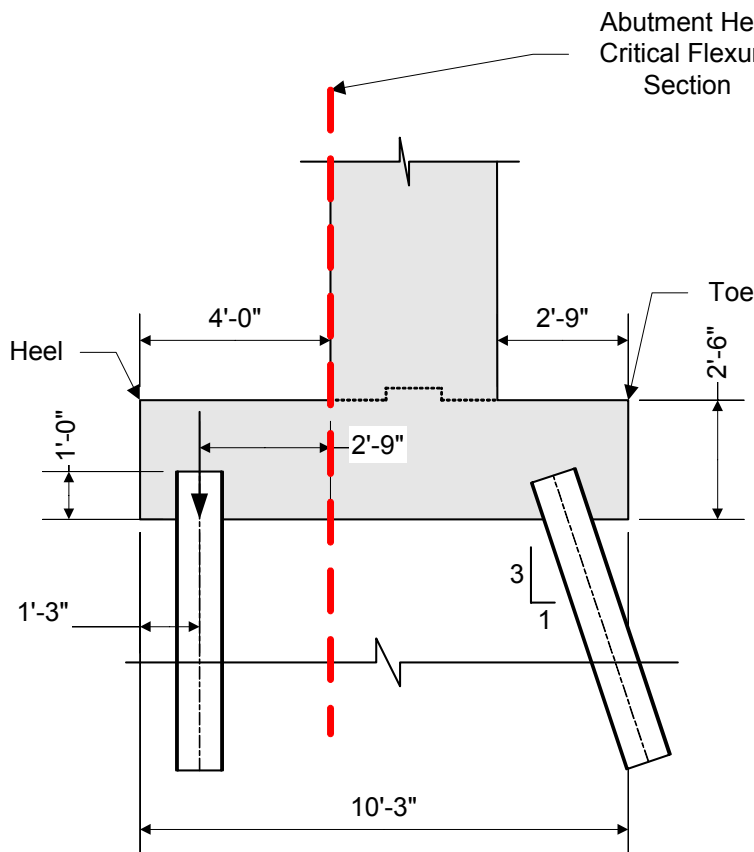

Figure 7-20 Abutment Heel Critical Flexure Section

The controlling moment on the critical section occurs when the pile loads on the back row of piles are minimized. From Tables P-17 to P-20, the back row pile loads are minimized for Strength I using the minimum load factors at the final construction condition and are summarized below. Piles in tension are shown as having negative pile loads.

$$\begin{aligned}
 P_1 &= -15.3\text{K} & P_9 &= -14.5\text{K} \\
 P_3 &= -14.8\text{K} & P_{11} &= -14.8\text{K} \\
 P_5 &= -14.5\text{K} & P_{13} &= -15.3\text{K} \\
 P_7 &= -14.4\text{K}
 \end{aligned}$$

Since the above pile loads are already factored, no load factors need to be applied and the total factored moment is as follows:

$$M_{u\text{heel}} = 2.75\text{ft} \cdot (P_1 + P_3 + P_5 + P_7 + P_9 + P_{11} + P_{13})$$

$$M_{u\text{heel}} = -284.90\text{K}\cdot\text{ft}$$

The moment on a per foot basis is then:

$$M_{u\text{heelft}} = \frac{M_{u\text{heel}}}{L_{\text{abut}}}$$

$$M_{u\text{heelft}} = -6.08 \text{ K} \cdot \frac{\text{ft}}{\text{ft}}$$

Once the moment at the critical section is known, the same procedure that was used for the toe must be followed. The flexure reinforcement for the footing heel is placed longitudinally along the top of the footing since the top of the footing heel is in tension at the critical heel section. The bars will extend from the back of the heel to the front of the toe taking into account the concrete cover.

Assume #5 bars:

$$\text{bar_diam} = 0.625 \text{ in}$$

$$\text{bar_area} = 0.31 \text{ in}^2$$

$$f_y = 60 \text{ ksi}$$

The footing heel critical section minimum tensile reinforcement requirements will be calculated. The tensile reinforcement provided must be enough to develop a factored flexural resistance at least equal to the lesser of 1.2 times the cracking strength or 1.33 times the factored moment from the applicable strength load combinations.

The cracking strength is calculated by:

$$M_{\text{Cr}} = \frac{f_r \cdot I_g}{y_t}$$

S5.7.3.3.2

SEquation
5.7.3.6.2-2

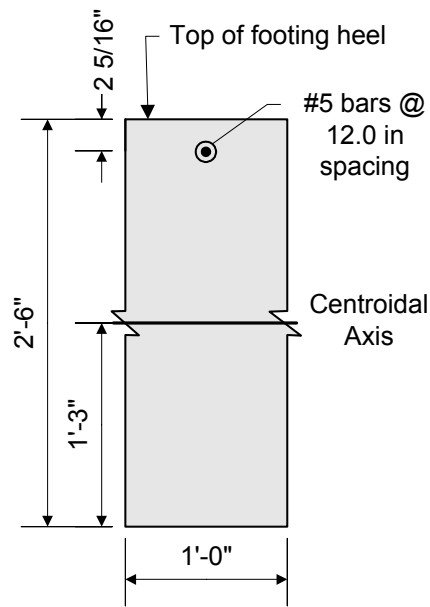

Figure 7-21 Abutment Footing Heel Cracking Moment Dimensions

$$f_r = 0.24 \cdot \sqrt{f'_c}$$

$$f_r = 0.48 \text{ ksi}$$

$$I_g = \frac{1}{12} (12 \text{ in}) (30 \text{ in})^3$$

$$I_g = 27000 \text{ in}^4$$

$$y_t = 15 \text{ in}$$

$$M_{cr} = \frac{-f_r I_g}{y_t}$$

$$M_{cr} = -72.00 \frac{\text{K} \cdot \text{ft}}{\text{ft}}$$

$$1.2 \cdot M_{cr} = -86.40 \frac{\text{K} \cdot \text{ft}}{\text{ft}}$$

1.33 times the factored controlling heel moment is:

$$1.33 \cdot M_{u\text{heel}} = -8.08 \frac{\text{K} \cdot \text{ft}}{\text{ft}}$$

S5.4.2.6

1.33 times the factored controlling heel moment controls the minimum reinforcement requirements. Use 1.33 times the factored controlling heel moment to design the heel flexure reinforcement.

$$M_{uftheeldes} = 1.33 \cdot (-M_{uheelft})$$

$$M_{uftheeldes} = 8.08 \frac{\text{K} \cdot \text{ft}}{\text{ft}}$$

Effective depth, d_e = total footing thickness - cover - 1/2 bar diameter

$$\text{thickness of footing: } t_{ftg} = 30\text{in}$$

$$\text{Cover}_{ft} = 2.00\text{in}$$

$$d_e = t_{ftg} - \text{Cover}_{ft} - \frac{\text{bar_diam}}{2}$$

$$d_e = 27.69\text{in}$$

Solve for the required amount of reinforcing steel, as follows:

$$\phi_f = 0.90$$

$$b = 12\text{in}$$

$$f_c = 4.0\text{ksi}$$

$$R_n = \frac{M_{uftheeldes} \cdot 12\text{in}}{(\phi_f \cdot b \cdot d_e^2)} \quad R_n = 0.012 \frac{\text{K}}{\text{in}^2}$$

$$\rho = 0.85 \left(\frac{f_c}{f_y} \right) \left[1.0 - \sqrt{1.0 - \frac{(2 \cdot R_n)}{(0.85 \cdot f_c)}} \right]$$

$$\rho = 0.00020$$

Note: The above two equations are derived formulas that can be found in most reinforced concrete textbooks.

$$A_s = \rho \cdot \frac{b}{ft} \cdot d_e \quad A_s = 0.06 \frac{\text{in}^2}{\text{ft}}$$

$$\text{Required bar spacing} = \frac{\text{bar_area}}{A_s} = 57.2\text{in}$$

S5.5.4.2.1

Use #5 bars @ $\text{bar_space} = 12.0\text{in}$

$$A_s = \text{bar_area} \cdot \left(\frac{12\text{in}}{\text{bar_space}} \right) \quad A_s = 0.31\text{in}^2 \text{ per foot}$$

Once the bar size and spacing are known, the maximum reinforcement limit must be checked.

S5.7.3.3.1

$$T = A_s \cdot f_y \quad T = 18.60\text{K}$$

$$a = \frac{T}{0.85 \cdot f_c \cdot b} \quad a = 0.46\text{in}$$

$$\beta_1 = 0.85$$

S5.7.2.2

$$c = \frac{a}{\beta_1} \quad c = 0.54\text{in}$$

S5.7.2.2

$$\frac{c}{d_e} = 0.02 \quad \text{where} \quad \frac{c}{d_e} \leq 0.42$$

S5.7.3.3.1

$$0.05 \leq 0.42 \quad \text{OK}$$

The crack control check for the footing heel critical section will not be carried out. The calculations are similar to that of the abutment backwall, stem, and footing toe.



Preliminary Design

A quick way to come up with a design section that will probably work for all design checks is to just check the crack control requirements for LRFD. It has been the designer's experience that in many footing designs, the crack control requirements control the footing design. The above is true for LRFD because LFD allows a certain percentage of overstress for the service cases due to the low probability that the loads combined for each service case will actually occur simultaneously.

Shrinkage and temperature reinforcement:

S5.10.8

For members less than 48.0 inches thick, the area of reinforcement in each direction shall not be spaced greater than 12.0 inches and satisfy the lesser of:

S5.10.8.2

$$A_s \geq 0.11 \frac{A_g}{f_y} \quad \text{or} \quad \Sigma A_b = 0.0015 A_g$$

$$A_g = (30 \cdot \text{in}) \cdot \left(12 \cdot \frac{\text{in}}{\text{ft}} \right) \quad A_g = 360.00 \frac{\text{in}^2}{\text{ft}}$$

$$f_y = 60 \text{ ksi}$$

$$0.11 \cdot \frac{A_g}{f_y} = 0.66 \frac{\text{in}^2}{\text{ft}}$$

or

$$0.0015 A_g = 0.54 \frac{\text{in}^2}{\text{ft}}$$

The total combined amount of reinforcing steel on the top and bottom transverse faces must be greater than or equal to 0.54 in²/ft.

For one face only:

$$A_{\text{stop}} = \frac{0.54 \frac{\text{in}^2}{\text{ft}}}{2} \quad A_{\text{stop}} = 0.27 \frac{\text{in}^2}{\text{ft}}$$

Try 1 # 5 bar at 12.0 inch spacing for one face:

$$\text{bar_diam} = 0.625 \text{ in}$$

$$\text{bar_area} = 0.31 \text{ in}^2$$

$$A_s = \frac{\text{bar_area} \cdot \left(\frac{12 \text{ in}}{12 \text{ in}} \right)}{\text{ft}} \quad A_s = 0.31 \frac{\text{in}^2}{\text{ft}}$$

$$0.31 \frac{\text{in}^2}{\text{ft}} \geq 0.27 \frac{\text{in}^2}{\text{ft}} \quad \text{OK}$$

Based on the abutment footing flexure design, #8 bars at 12.0 inch spacing are required for the bottom longitudinal flexure reinforcement. #5 bars at 12.0 inch spacing are required for the top longitudinal flexure reinforcement. In the footing transverse direction, the shrinkage and temperature reinforcement calculations require #5 bars at 12.0 inch spacing for the top and bottom mats.

Design for shear:

Shear design in abutment footings consists of having adequate resistance against one-way action and two-way action. For both one-way and two-way actions, the design shear is taken at a critical section. For abutments, one-way action is checked in the toe and heel. The factored shear force at the critical section is computed by cutting the footing at the critical section and summing the pile loads or portions of pile loads that are outside the critical section. Two-way action in abutment footings supported by piles is generally checked taking a critical perimeter around individual piles or around a group of piles when the critical perimeter of individual piles overlap.

For one way action in the abutment footing toe, the critical section is taken as the larger of:

$$0.5 \cdot d_v \cdot \cot \theta \quad \text{or} \quad d_v$$

$$\theta = 45 \text{deg}$$

The term d_v is calculated the same as it is for the backwall and stem:

$$d_v = \max \left(d_e - \frac{a}{2}, 0.9 \cdot d_e, 0.72 \cdot h \right)^{\blacksquare}$$

where:

$$d_e = 26.50 \text{ in} \quad \text{taken from footing toe strength flexure design}$$

$$a = 1.16 \text{ in} \quad \text{taken from footing toe strength flexure design}$$

$$h = 30 \text{ in}$$

$$d_v = 25.92$$

Now the critical section can be calculated:

$$0.5 \cdot d_v \cdot \cot(\theta) = 12.96 \text{ in} \quad \text{or} \quad d_v = 25.92 \text{ in}$$

$$\text{use } d_v = 25.92 \text{ in}$$

S5.13.3.6

S5.13.3.6.1 &
S5.8.3.2

S5.8.2.9

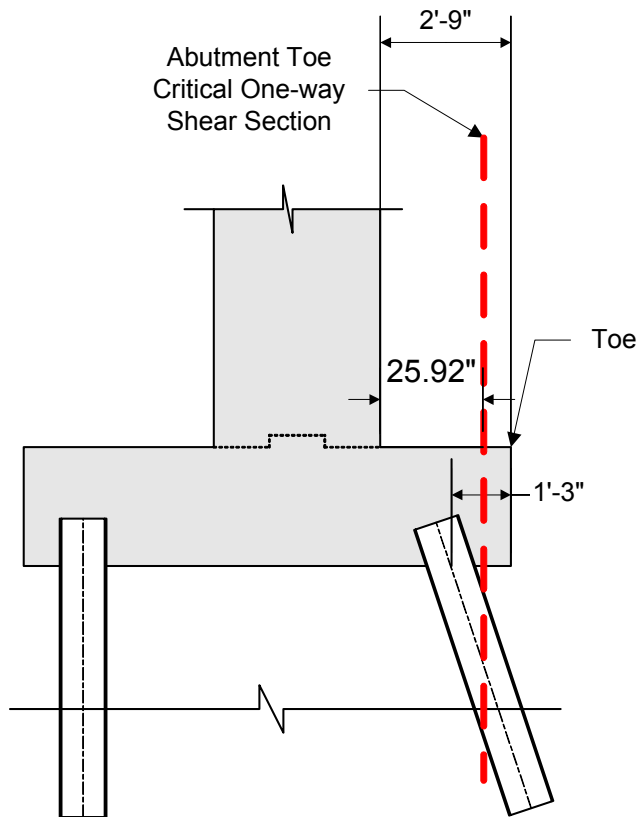

Figure 7-22 Abutment Toe One-way Action Critical Section

Since the front row of piles are all inside the critical section, the factored shear outside the critical section is zero and does not have to be checked. However, the manner in which the design shear force would be calculated if the front row of piles were outside the critical section is shown below. Note that this check is not required and does not apply since the front row of piles are all inside the critical section.

The pile loads used to compute the controlling footing toe shear force are for the Strength I limit state using the maximum load factors at the final construction stage. They are taken from Design Step P, Tables P-17 through P-20 and are as follows:

$$\begin{aligned}
 P_2 &= 314.5\text{K} & P_{10} &= 335.3\text{K} \\
 P_4 &= 330.3\text{K} & P_{12} &= 330.5\text{K} \\
 P_6 &= 336.0\text{K} & P_{14} &= 314.8\text{K} \\
 P_8 &= 339.9\text{K}
 \end{aligned}$$

The factored one-way shear force at the abutment footing toe critical section on a per foot basis is then:

$$V_{uftgtoe} = \frac{(P_2 + P_4 + P_6 + P_8 + P_{10} + P_{12} + P_{14})}{L_{abut}}$$

$$V_{uftgtoe} = 49.09 \frac{K}{ft}$$

The nominal shear resistance is the lesser of:

$$V_{n1} = V_c + V_s$$

or

$$V_{n2} = 0.25 \cdot f_c \cdot b_v \cdot d_v$$

where:

$$V_c = 0.0316 \cdot \beta \cdot \sqrt{f_c} \cdot b_v \cdot d_v$$

and

$$V_s = \frac{A_v \cdot f_y \cdot d_v \cdot (\cot\theta + \cot\alpha) \cdot \sin\alpha}{s} \quad \text{neglect for this abutment design}$$

Before the nominal shear resistance can be calculated, all the variables used in the above equations need to be defined.

$$\beta = 2.0$$

$$b_v = 12 \text{ in}$$

$$d_v = 25.92 \text{ in}$$

Now, V_{n1} and V_{n2} can be calculated:

$$\text{For } f_c = 4.0 \text{ ksi}$$

$$V_{n1} = 0.0316 \cdot \beta \cdot \sqrt{f_c} \cdot b_v \cdot d_v$$

$$V_{n1} = 39.32 \frac{K}{ft}$$

$$V_{n2} = 0.25 \cdot f_c \cdot b_v \cdot d_v$$

$$V_{n2} = 311.04 \frac{K}{ft}$$

$$\text{Use: } V_n = 39.32 \frac{K}{ft}$$

S5.8.3.3

S5.8.3.4.1

S5.8.2.9

The factored shear resistance is then:

$$\phi_v = 0.90$$

$$V_r = \phi_v \cdot V_n$$

$$V_r = 35.39 \frac{\text{K}}{\text{ft}}$$

$$V_r < V_{\text{uftgtoe}} \quad \text{N.G.}$$

S5.5.4.2.1

If the front row of piles were outside the critical section, the one-way shear for the abutment footing toe would fail. The footing depth would have to be increased or the piles would have to be redesigned to reduce the shear force outside the critical section. Again, the above design shear force and resistance are just shown to illustrate the toe one-way shear check if the pile loads were outside the critical section.

For one way action in the abutment footing heel, the critical section is taken at the abutment face for heels that are in tension on the top face of the heel. For heels that are in compression on the top face, the critical section is calculated according to S5.8.2.9. The maximum factored abutment footing heel shear occurs when the heel is in tension on the top face. Therefore, the critical section is taken at the stem back face.

S5.13.3.6.1 &
C5.13.3.6.1

The term d_v is calculated the same as it is for the abutment toe:

$$d_v = \max\left(d_e - \frac{a}{2}, 0.9 \cdot d_e, 0.72 \cdot h\right)^{\blacksquare}$$

S5.8.2.9

where:

$$d_e = 26.50 \text{ in} \quad \text{use the same effective depth as the toe - conservative}$$

$$a = 1.16 \text{ in} \quad \text{use the same stress block depth as the toe - conservative}$$

$$h = 30 \text{ in}$$

$$d_v = 25.92 \text{ in}$$

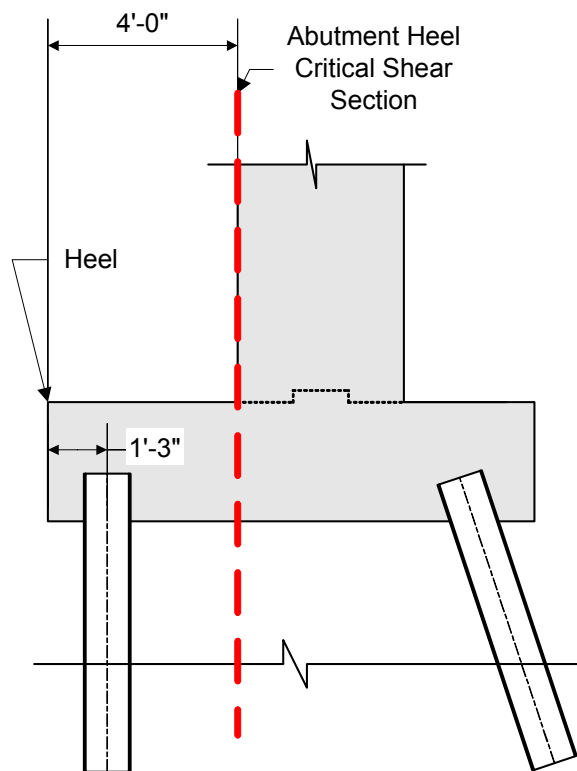

Figure 7-23 Abutment Heel One-way Action Critical Section

Since the back row of piles are all outside the critical section, the factored shear is computed by summing all the back row pile loads.

The pile loads used to compute the controlling footing heel shear force are for the Strength I limit state using the minimum load factors at the final construction stage. They are taken from Design Step P, Tables P-17 through P-20 and are as follows:

$$\begin{array}{ll}
 P_1 = -15.3K & P_9 = -14.5K \\
 P_3 = -14.8K & P_{11} = -14.8K \\
 P_5 = -14.5K & P_{13} = -15.3K \\
 P_7 = -14.4K &
 \end{array}$$

The factored one-way shear force at the abutment footing heel critical section on a per foot basis is then:

$$V_{\text{uftgheel}} = \frac{(P_1 + P_3 + P_5 + P_7 + P_9 + P_{11} + P_{13})}{L_{\text{abut}}}$$

$$V_{\text{uftgheel}} = -2.21 \frac{\text{K}}{\text{ft}}$$

The nominal shear resistance is the lesser of:

$$V_{n1} = V_c + V_s$$

or

$$V_{n2} = 0.25 \cdot f_c \cdot b_v \cdot d_v$$

where:

$$V_c = 0.0316 \cdot \beta \cdot \sqrt{f_c} \cdot b_v \cdot d_v$$

and

$$V_s = \frac{A_v \cdot f_y \cdot d_v \cdot (\cot\theta + \cot\alpha) \cdot \sin\alpha}{s} \quad \text{neglect for this abutment design}$$

Before the nominal shear resistance can be calculated, all the variables used in the above equations need to be defined.

$$\beta = 2.0$$

$$b_v = 12 \text{ in}$$

$$d_v = 25.92 \text{ in}$$

Now, V_{n1} and V_{n2} can be calculated:

$$\text{For } f_c = 4.0 \text{ ksi}$$

$$V_{n1} = 0.0316 \cdot \beta \cdot \sqrt{f_c} \cdot b_v \cdot d_v$$

$$V_{n1} = 39.32 \frac{\text{K}}{\text{ft}}$$

$$V_{n2} = 0.25 \cdot f_c \cdot b_v \cdot d_v$$

$$V_{n2} = 311.04 \frac{\text{K}}{\text{ft}}$$

$$\text{Use: } V_n = 39.32 \frac{\text{K}}{\text{ft}}$$

S5.8.3.3

S5.8.3.4.1

S5.8.2.9

The factored shear resistance is then:

$$\phi_v = 0.90$$

$$V_r = \phi_v \cdot V_n$$

$$V_r = 35.39 \frac{\text{K}}{\text{ft}}$$

$$V_r > V_{\text{uftgheel}} \quad \text{OK}$$

S5.5.4.2.1

For two-way action, the pile critical perimeter, b_o , is located a minimum of $0.5d_v$ from the perimeter of the pile. If portions of the critical perimeter are located off the footing, that portion of the critical perimeter is limited by the footing edge.

S5.13.3.6.1

Two-way action should be checked for the maximum loaded pile, or pile # 8 (see Design Step P - Tables P-17 through P-20). The effective shear depth, d_v , is the same as that used for the one-way shear check for the footing toe.

$$V_{\text{utwoway}} = P_8$$

$$V_{\text{utwoway}} = 339.90 \text{ K}$$

$$d_v = 25.92 \text{ in}$$

$$0.5 \cdot d_v = 12.96 \text{ in}$$

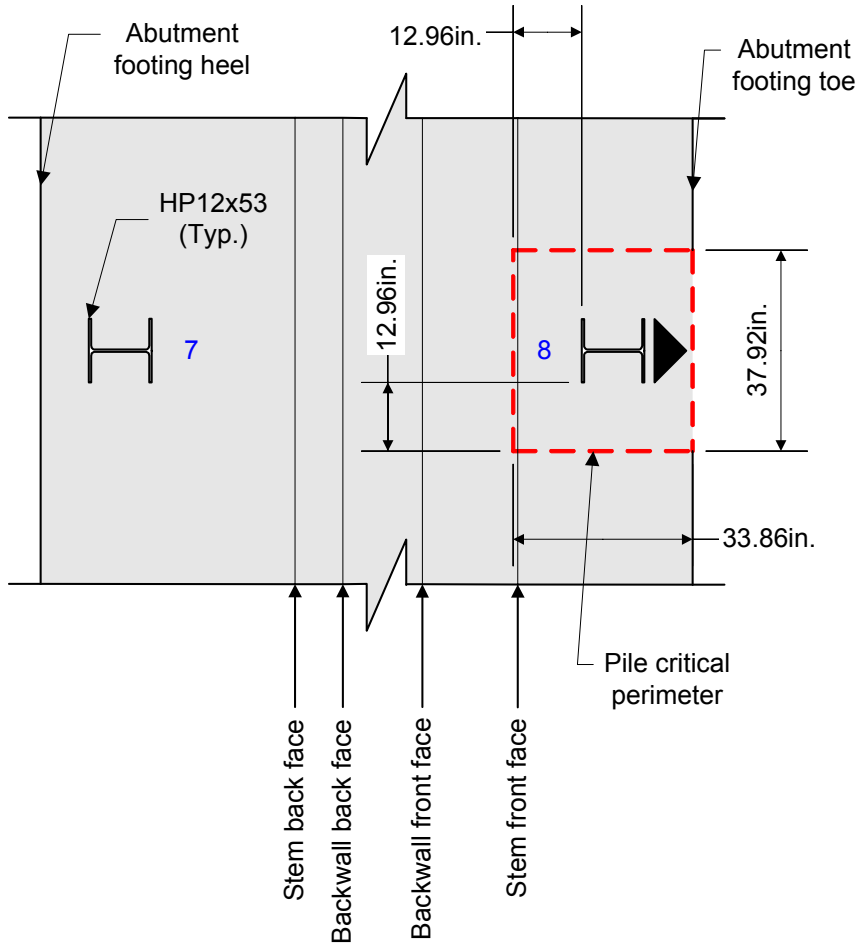

Figure 7-24 Pile Two-way Action Critical Perimeter

In the above figure, it can be seen that the critical perimeter is approximately at the face of the stem. In fact, the critical perimeter overlaps the front face of the stem by approximately 0.07 inches. Since the overlap is minimal, ignore the overlap and assume the critical perimeter and the front face of the stem are aligned at the same plane.

Two-way action or punching shear resistance for sections without transverse reinforcement can then be calculated as follows:

S5.13.3.6.3

$$V_n = \left(0.063 + \frac{0.126}{\beta_c} \right) \cdot \sqrt{f'_c} \cdot b_o \cdot d_v \leq 0.126 \cdot \sqrt{f'_c} \cdot b_o \cdot d_v$$

$$\beta_c = \frac{37.92 \text{ in}}{33.86 \text{ in}} \quad \text{ratio of long to short side of critical perimeter}$$

$$\beta_c = 1.12$$

$$b_o = 2 \cdot (33.86 + 37.92) \text{ in}$$

$$b_o = 143.56 \text{ in}$$

$$\left(0.063 + \frac{0.126}{\beta_c} \right) \cdot \sqrt{f'_c} \cdot b_o \cdot d_v = 1306.17 \text{ K}$$

$$0.126 \cdot \sqrt{f'_c} \cdot b_o \cdot d_v = 937.71 \text{ K}$$

$$\text{use } V_n = 937.71 \text{ K}$$

The factored punching shear resistance is then:

$$\phi_v = 0.90$$

S5.5.4.2.1

$$V_r = \phi_v \cdot V_n$$

$$V_r = 843.94 \text{ K}$$

$$V_r > V_{\text{utwoway}} \quad \text{OK}$$

Design Step 7.12 - Draw Schematic of Final Abutment Design

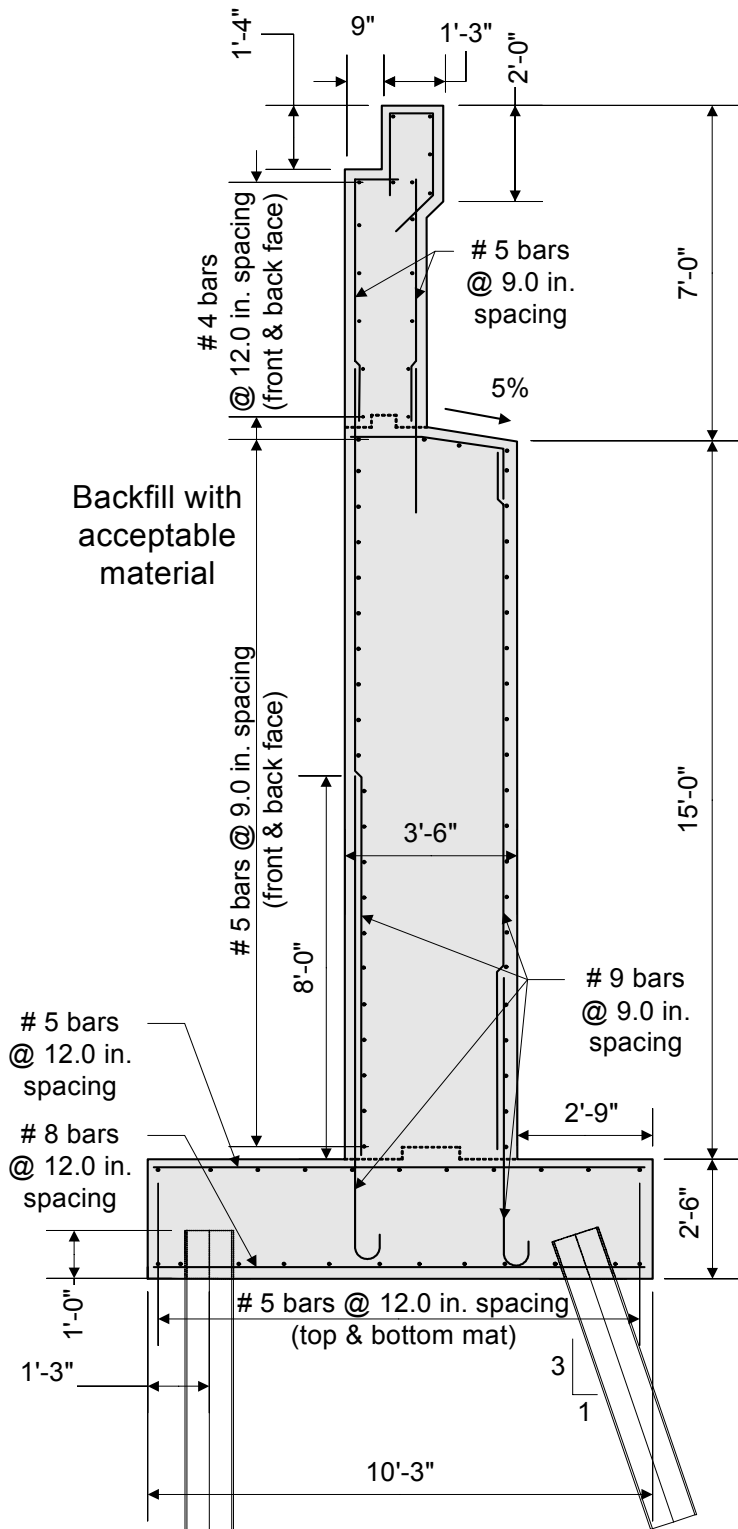

Figure 7-25 Final Abutment Design

Design Step 7.2 - Select Optimum Wingwall Type

Selecting the most optimal wingwall type depends on the site conditions, cost considerations, and aesthetics. Wingwalls can be integral or independent. Wingwall classifications include most of the abutment types listed in the abutment section. For this design example, a reinforced concrete cantilever wingwall was chosen. The wingwall is skewed at a 45 degree angle from the front face of the abutment stem. S11.2

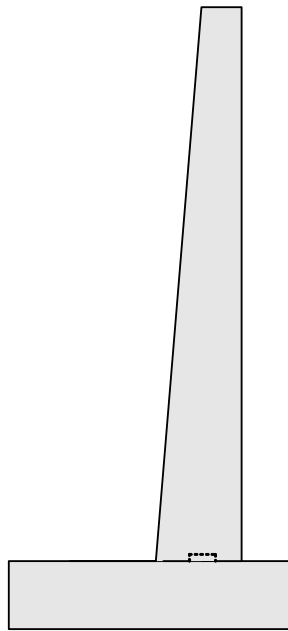

Figure 7- 26 Reinforced Concrete Cantilever Wingwall

Design Step 7.3 - Select Preliminary Wingwall Dimensions

The designer should base the preliminary wingwall dimensions on state specific standards, previous designs, and past experience.

The following figure shows the preliminary dimensions for the wingwall.

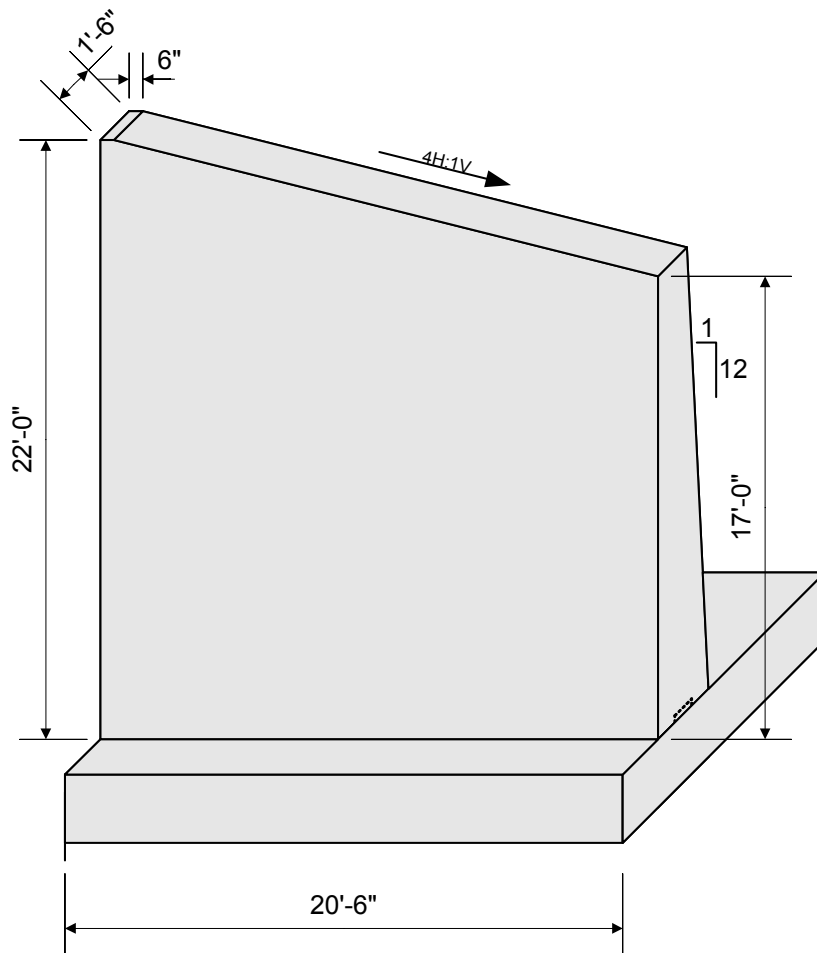

Figure 7-27 Preliminary Wingwall Dimensions

Design Step 7.4 - Compute Dead Load Effects

Once the preliminary wingwall dimensions are selected, the corresponding dead loads can be computed. The dead loads are calculated on a per foot basis. For sloped wingwalls, the design section is generally taken at a distance of one-third down from the high end of the wingwall.

S3.5.1

Design section stem height:

Distance from start of slope at high end of stem:

$$\frac{(20.5\text{ft})}{3} = 6.83\text{ft}$$

Amount wingwall stem drops per foot:

$$\frac{(22\text{ft} - 17\text{ft})}{20\text{ft}} = 0.25 \frac{\text{ft}}{\text{ft}}$$

The wingwall design height is then:

$$H_{\text{wing}} = 22\text{ft} - \left[(6.83\text{ft} - 0.5\text{ft}) \cdot 0.25 \frac{\text{ft}}{\text{ft}} \right]$$

$$H_{\text{wing}} = 20.42\text{ft}$$

$$\text{Use } H_{\text{wing}} = 20.50\text{ft}$$

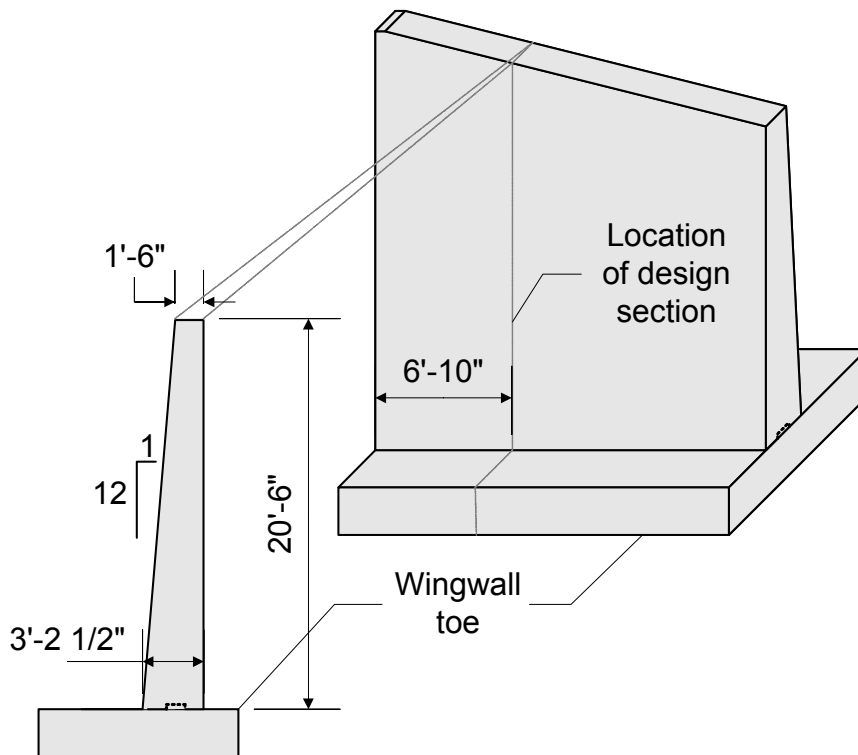

Figure 7-28 Wingwall Design Section

Wingwall stem:

$$DL_{wwstem} = \left[\left(\frac{1.5ft + 3.21ft}{2} \right) \cdot 20.50ft \right] \cdot W_c$$

$$DL_{wwstem} = 7.24 \frac{K}{ft}$$

Design Step 7.5 - Compute Live Load Effects

Since the wingwall does not support a parapet, the only live load effects are from live load surcharge. The effects from live load surcharge are computed in Design Step 7.6.

Design Step 7.6 - Compute Other Load Effects

Other load effects that need to be computed include: wind loads, earthquake loads, earth pressure, live load surcharge, and temperature loads.

Wind Load on Wingwall

The wind loads acting on the exposed portion of the wingwall front and end elevations are calculated from a base wind pressure of 0.040 KSF. In the wingwall final state, the wind loads acting on the wingwall will only decrease the overturning moment and will be ignored for this design example. For the wingwall temporary state, the wind loads acting on the wingwall should be investigated. Also, any wind loads that produce a transverse shear or moment in the wingwall footing are ignored. The reason for this is due to the fact that the majority of force effects required to produce a transverse shear or moment will also reduce the maximum overturning moment.

S3.8.1.2.3

Earthquake Load

This design example assumes that the structure is located in seismic zone I with an acceleration coefficient of 0.02. For seismic zone I, no seismic analysis is required.

S3.10

Earth Loads

The earth loads that need to be investigated for this design example include: loads due to basic lateral earth pressure, loads due to uniform surcharge, and live load surcharge loads.

S3.11

S3.11.5

S3.11.6

Loads due to basic lateral earth pressure:

To obtain the lateral loads due to basic earth pressure, the earth pressure (p) must first be calculated from the following equation.

$$p = k_a \cdot \gamma_s \cdot z^2$$

Bottom of wingwall stem lateral earth load:

$k_a = 0.3$ obtained from geotechnical information

$\gamma_s = 0.120 \text{ kcf}$ use average of loose and compacted gravel

$z = 20.5 \text{ ft} + 2.0 \text{ ft}$ Depth below the surface of the earth

$$p = k_a \cdot \gamma_s \cdot z$$

$$p = 0.81 \text{ ksf}$$

S3.11.5

S3.11.5.1

STable 3.5.1-1

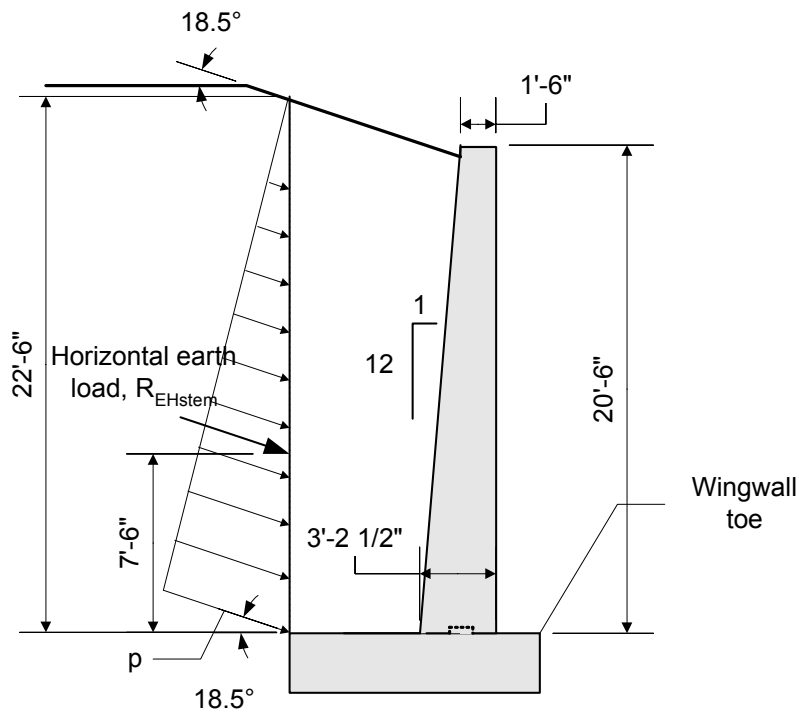

Figure 7-29 Wingwall Stem Design Earth Pressure

Once the lateral earth pressure is calculated, the lateral load due to the earth pressure can be calculated. This load acts at a distance of $H/3$ from the bottom of the section being investigated. For cases where the ground line is sloped, H is taken as the height from the top of earth to the bottom of the section being investigated.

$$h_{wwstem} = 20.5\text{ft} + 2.0\text{ft}$$

$$R_{EHstem} = \left(\frac{1}{2}\right) \cdot p \cdot h_{wwstem}$$

$$R_{EHstem} = 9.11 \frac{\text{K}}{\text{ft}}$$

Since the ground line is sloped, R_{EHstem} , must be broken down into horizontal and vertical components as follows:

$$R_{EHstemhoriz} = R_{EHstem} \cdot \cos(18.5\text{deg})$$

$$R_{EHstemhoriz} = 8.64 \frac{\text{K}}{\text{ft}}$$

$$R_{EHstemvert} = R_{EHstem} \cdot \sin(18.5\text{deg})$$

$$R_{EHstemvert} = 2.89 \frac{\text{K}}{\text{ft}}$$

Loads due to uniform surcharge:

Since an approach slab and roadway will cover the abutment backfill material, no uniform surcharge load will be applied.

Loads due to live load surcharge:

Loads due to live load surcharge must be applied when a vehicular live load acts on the backfill surface behind the backface within one-half the wall height. Since the distance from the wingwall back face to the edge of traffic is greater than one foot, the equivalent height of fill is constant. The horizontal pressure increase due to live load surcharge is estimated based on the following equation:

$$\Delta p = k \cdot \gamma_s \cdot h_{eq}^2$$

S3.11.5.1

SC3.11.5.1

S3.11.6.1

S3.11.6.4

Bottom of wingwall stem live load surcharge load:

$$k = k_a$$

$$\gamma_s = 0.120 \text{ kcf} \quad \text{use average of loose and compacted gravel}$$

$$h_{eq} = 2.0 \text{ ft} \quad \text{equivalent height of soil for vehicular loading}$$

$$\Delta_p = k \cdot \gamma_s \cdot h_{eq}$$

$$\Delta_p = 0.072 \text{ ksf}$$

The lateral load due to the live load surcharge is:

$$R_{LSstem} = \Delta_p \cdot h_{wwstem}$$

$$R_{LSstem} = 1.62 \frac{\text{K}}{\text{ft}}$$

Since the ground line is sloped, R_{LSstem} , must be broken down into horizontal and vertical components as follows:

$$R_{LSstemhoriz} = R_{LSstem} \cdot \cos(18.5 \text{ deg})$$

$$R_{LSstemhoriz} = 1.54 \frac{\text{K}}{\text{ft}}$$

$$R_{LSstemvert} = R_{LSstem} \cdot \sin(18.5 \text{ deg})$$

$$R_{LSstemvert} = 0.51 \frac{\text{K}}{\text{ft}}$$

Loads due to temperature:

Temperature loads are not applicable for the wingwall design.

Design Step 7.7 - Analyze and Combine Force Effects

There are two critical locations where the force effects need to be combined and analyzed for design. They include: the bottom of stem or top of footing and the bottom of footing. For the stem design, transverse horizontal loads do not need be considered due to the high moment of inertia about that axis, but at the bottom of footing, the transverse horizontal loads will need to be considered for the footing and pile design. Note that the footing design calculations for wingwalls are similar to abutments. Therefore, the wingwall footing design calculations will not be shown.

STable 3.5.1-1

STable 3.11.6.4-1

S3.12

Bottom of Wingwall Stem

The combination of force effects for the bottom of the wingwall stem includes:

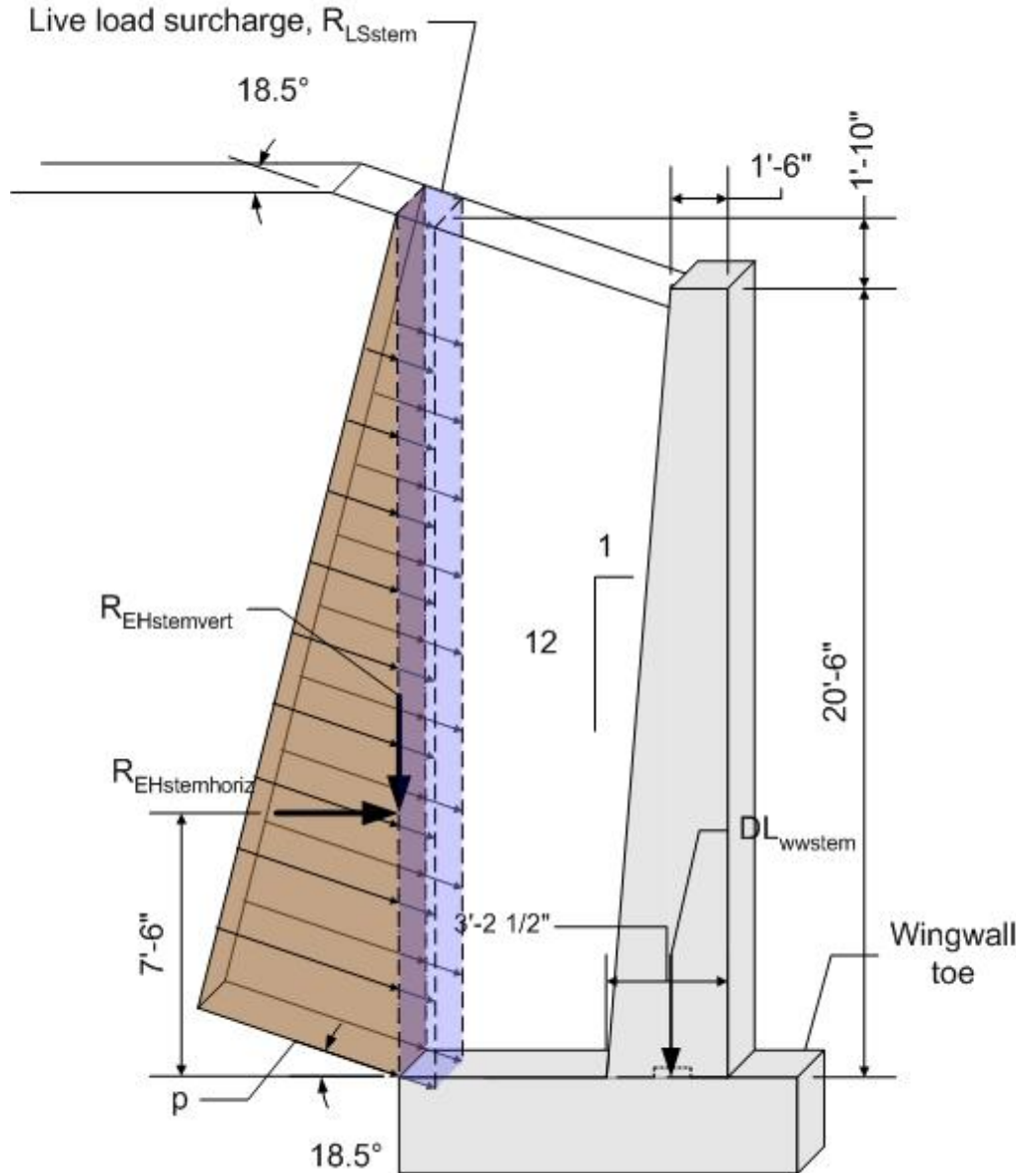

Figure 7-30 Wingwall Stem Dimensions and Loading

The force effects for the wingwall stem will be combined for the following limit states.

Load	Load Factors							
	Strength I		Strength III		Strength V		Service I	
	γ_{max}	γ_{min}	γ_{max}	γ_{min}	γ_{max}	γ_{min}	γ_{max}	γ_{min}
DC	1.25	0.90	1.25	0.90	1.25	0.90	1.00	1.00
EH	1.50	0.90	1.50	0.90	1.50	0.90	1.00	1.00
LS	1.75	1.75	---	---	1.35	1.35	1.00	1.00

STable 3.4.1-1

STable 3.4.1-2

Table 7-7 Applicable Wingwall Stem Limit States with the Corresponding Load Factors

The loads that are required to combine force effects at the base of the wingwall stem include:

$$DL_{wwstem} = 7.24 \frac{K}{ft}$$

$$R_{EHstemhoriz} = 8.64 \frac{K}{ft}$$

$$R_{LSstemhoriz} = 1.54 \frac{K}{ft}$$

Wingwall stem Strength I force effects:

The following load factors will be used to calculate the controlling force effects for Strength I:

$$\gamma_{DC} = 1.25$$

$$\gamma_{EH} = 1.50$$

$$\gamma_{LS} = 1.75$$

STable 3.4.1-2

STable 3.4.1-2

STable 3.4.1-1

The factored vertical force at the base of the wingwall stem is:

$$F_{vstmstrl} = \gamma_{DC} \cdot DL_{wwstem}$$

$$F_{vstmstrl} = 9.05 \frac{K}{ft}$$

The factored longitudinal shear force at the base of the wingwall stem is:

$$V_{ustmstrI} = (\gamma_{EH} \cdot R_{EHstemhoriz}) + (\gamma_{LS} \cdot R_{LSstemhoriz})$$

$$V_{ustmstrI} = 15.65 \frac{K}{ft}$$

The factored moment about the bridge transverse axis at the base of the wingwall stem is:

$$M_{ustmstrI} = (\gamma_{EH} \cdot R_{EHstemhoriz} \cdot 7.5 \cdot ft) \dots \\ + (\gamma_{LS} \cdot R_{LSstemhoriz} \cdot 11.25 \cdot ft)$$

$$M_{ustmstrI} = 127.46 \frac{K \cdot ft}{ft}$$

Wingwall stem Strength III force effects:

The following load factors will be used to calculate the force effects for Strength III:

$$\gamma_{DC} = 1.25$$

$$\gamma_{EH} = 1.50$$

STable 3.4.1-2

STable 3.4.1-2

The factored vertical force at the base of the wingwall stem is:

$$F_{vstmstrIII} = \gamma_{DC} \cdot DL_{wwstem}$$

$$F_{vstmstrIII} = 9.05 \frac{K}{ft}$$

The factored longitudinal shear force at the base of the abutment stem is:

$$V_{ustmstrIII} = \gamma_{EH} \cdot R_{EHstemhoriz}$$

$$V_{ustmstrIII} = 12.96 \frac{K}{ft}$$

The factored longitudinal moment at the base of the wingwall stem is:

$$M_{ustmstrIII} = \gamma_{EH} \cdot R_{EHstemhoriz} \cdot 7.5 \cdot ft$$

$$M_{ustmstrIII} = 97.22 \frac{K \cdot ft}{ft}$$

Wingwall stem Strength V force effects:

The following load factors will be used to calculate the force effects for Strength V:

$$\gamma_{DC} = 1.25$$

$$\gamma_{EH} = 1.50$$

$$\gamma_{LS} = 1.35$$

STable 3.4.1-2

STable 3.4.1-2

STable 3.4.1-1

The factored vertical force at the base of the wingwall stem is:

$$F_{vstmstrV} = \gamma_{DC} \cdot DL_{wwstem}$$

$$F_{vstmstrV} = 9.05 \frac{K}{ft}$$

The factored longitudinal shear force at the base of the wingwall stem is:

$$V_{ustmstrV} = (\gamma_{EH} \cdot R_{EHstemhoriz}) + (\gamma_{LS} \cdot R_{LSstemhoriz})$$

$$V_{ustmstrV} = 15.04 \frac{K}{ft}$$

The factored longitudinal moment at the base of the wingwall stem is:

$$M_{ustmstrV} = (\gamma_{EH} \cdot R_{EHstemhoriz} \cdot 7.5 \cdot ft) \dots \\ + (\gamma_{LS} \cdot R_{LSstemhoriz} \cdot 11.25 \cdot ft)$$

$$M_{ustmstrV} = 120.55 \frac{K \cdot ft}{ft}$$

Wingwall stem Service I force effects:

The following load factors will be used to calculate the force effects for Service I:

$$\gamma_{DC} = 1.00$$

$$\gamma_{EH} = 1.00$$

$$\gamma_{LS} = 1.00$$

STable 3.4.1-2

STable 3.4.1-2

STable 3.4.1-1

The factored vertical force at the base of the wingwall stem is:

$$F_{vstm\text{serv}I} = \gamma_{DC} \cdot DL_{ww\text{stem}}$$

$$F_{vstm\text{serv}I} = 7.24 \frac{\text{K}}{\text{ft}}$$

The factored longitudinal shear force at the base of the wingwall stem is:

$$V_{ustm\text{serv}I} = (\gamma_{EH} \cdot R_{EH\text{stemhoriz}}) + (\gamma_{LS} \cdot R_{LS\text{stemhoriz}})$$

$$V_{ustm\text{serv}I} = 10.18 \frac{\text{K}}{\text{ft}}$$

The factored longitudinal moment at the base of the wingwall stem is:

$$M_{ustm\text{serv}I} = (\gamma_{EH} \cdot R_{EH\text{stemhoriz}} \cdot 7.5 \cdot \text{ft}) \dots \\ + (\gamma_{LS} \cdot R_{LS\text{stemhoriz}} \cdot 11.25 \cdot \text{ft})$$

$$M_{ustm\text{serv}I} = 82.10 \frac{\text{K} \cdot \text{ft}}{\text{ft}}$$

The maximum factored wingwall stem vertical force, shear force, and moment for the strength limit state are:

$$F_{\text{vertstemmax}} = \max(F_{\text{vstmstrI}}, F_{\text{vstmstrIII}}, F_{\text{vstmstrV}})$$

$$F_{\text{vertstemmax}} = 9.05 \frac{\text{K}}{\text{ft}}$$

$$V_{\text{uwwstemmax}} = \max(V_{\text{ustmstrI}}, V_{\text{ustmstrIII}}, V_{\text{ustmstrV}})$$

$$V_{\text{uwwstemmax}} = 15.65 \frac{\text{K}}{\text{ft}}$$

$$M_{\text{uwwstemmax}} = \max(M_{\text{ustmstrI}}, M_{\text{ustmstrIII}}, M_{\text{ustmstrV}})$$

$$M_{\text{uwwstemmax}} = 127.46 \frac{\text{K}\cdot\text{ft}}{\text{ft}}$$

Design Step 7.9 - Design Wingwall StemDesign for flexure:

Assume #9 bars:

$$\text{bar_diam} = 1.128\text{in}$$

$$\text{bar_area} = 1.00\text{in}^2$$

First, the minimum reinforcement requirements will be calculated. The tensile reinforcement provided must be enough to develop a factored flexural resistance at least equal to the lesser of 1.2 times the cracking strength or 1.33 times the factored moment from the applicable strength load combinations.

The cracking strength is calculated by:

$$M_{cr} = \frac{f_r \cdot I_g}{y_t}$$

S5.7.3.3.2

SEquation
5.7.3.6.2-2

Figure 7-31 Wingwall Cracking Moment Dimensions

S5.4.2.6

$$f_r = 0.24 \cdot \sqrt{f'_c}$$

$$f_r = 0.48 \text{ksi}$$

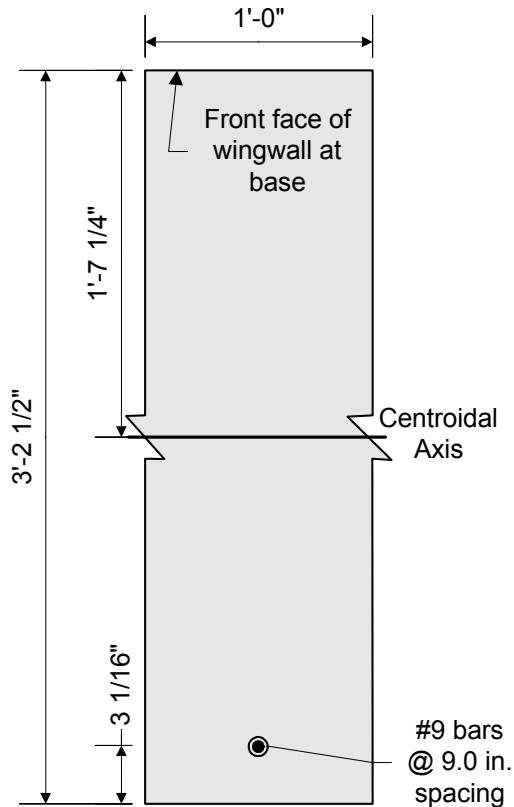
$$I_g = \frac{1}{12} (12 \text{in}) (38.5 \text{in})^3 \quad I_g = 57067 \text{in}^4$$

$$y_t = 19.25 \text{in}$$

$$M_{Cr} = \frac{f_r I_g}{y_t} \quad M_{Cr} = 118.58 \frac{\text{K} \cdot \text{ft}}{\text{ft}}$$

$$1.2 \cdot M_{Cr} = 142.30 \frac{\text{K} \cdot \text{ft}}{\text{ft}}$$

1.33 times the factored controlling backwall moment is:

$$M_{Uwwstemmax} = 127.46 \frac{\text{K} \cdot \text{ft}}{\text{ft}}$$

$$1.33 \cdot M_{Uwwstemmax} = 169.53 \frac{\text{K} \cdot \text{ft}}{\text{ft}}$$

1.2 times the cracking moment controls the minimum reinforcement requirements. 1.2 times the cracking moment is also greater than the factored wingwall stem moment. Therefore, use 1.2 times the cracking moment to design the wingwall stem flexure reinforcement.

$$M_{Uwwstemdes} = 1.2 \cdot M_{Cr}$$

$$M_{Uwwstemdes} = 142.30 \frac{\text{K} \cdot \text{ft}}{\text{ft}}$$

Effective depth, d_e = total backwall thickness - cover - 1/2 bar diameter

$$t_{bw} = 38.5 \text{in} \quad \text{wingwall thickness at base}$$

$$\text{Cover}_s = 2.50 \text{in}$$

$$d_e = t_{bw} - \text{Cover}_s - \frac{\text{bar_diam}}{2}$$

$$d_e = 35.44 \text{in}$$

Solve for the required amount of reinforcing steel, as follows:

$$\phi_f = 0.90$$

$$b = 12\text{in}$$

$$f_c = 4.0\text{ksi}$$

$$f_y = 60\text{ksi}$$

$$R_n = \frac{M_{U_{\text{Ww}} \text{stem des}} \cdot 12\text{in}}{(\phi_f \cdot b \cdot d_e^2)} \quad R_n = 0.13\text{ksi}$$

$$\rho = 0.85 \left(\frac{f_c}{f_y} \right) \left[1.0 - \sqrt{1.0 - \frac{(2 \cdot R_n)}{(0.85 \cdot f_c)}} \right] \quad \rho = 0.00214$$

Note: The above two equations are derived formulas that can be found in most reinforced concrete textbooks.

$$A_s = \rho \cdot \frac{b}{\text{ft}} \cdot d_e \quad A_s = 0.91 \frac{\text{in}^2}{\text{ft}}$$

$$\text{Required bar spacing} = \frac{\text{bar_area}}{A_s} = 13.2\text{in}$$

Use #9 bars @ $\text{bar_space} = 9.0\text{in}$ to match the abutment stem vertical bar spacing

$$A_s = \text{bar_area} \cdot \left(\frac{12\text{in}}{\text{bar_space}} \right) \quad A_s = 1.33\text{in}^2 \text{ per foot}$$

Once the bar size and spacing are known, the maximum reinforcement limit must be checked.

$$T = A_s \cdot f_y \quad T = 80.00\text{K}$$

$$a = \frac{T}{0.85 \cdot f_c \cdot b} \quad a = 1.96\text{in}$$

$$\beta_1 = 0.85$$

$$c = \frac{a}{\beta_1} \quad c = 2.31\text{in}$$

$$\frac{c}{d_e} = 0.07 \quad \text{where} \quad \frac{c}{d_e} \leq 0.42$$

$$0.07 \leq 0.42 \quad \text{OK}$$

S5.5.4.2.1

S5.7.3.3.1

S5.7.2.2

S5.7.2.2

S5.7.3.3.1

Check crack control:

The control of cracking by distribution of reinforcement must be checked.

S5.7.3.4

Since this design example assumes that the wingwall will be exposed to deicing salts, use:

$$Z = 130 \frac{\text{K}}{\text{in}}$$

Thickness of clear cover used to compute d_c should not be greater than 2 inches:

$$d_c = 2.5\text{in} + \frac{\text{bar_diam}}{2}$$

$$d_c = 3.06\text{in}$$

use $d_c = 2.0\text{in} + \frac{\text{bar_diam}}{2}$

$$d_c = 2.56\text{in}$$

Concrete area with centroid the same as transverse bar and bounded by the cross section and line parallel to neutral axis:

$$A_c = 2 \cdot (d_c) \cdot \text{bar_space}$$

$$A_c = 46.15\text{in}^2$$

The equation that gives the allowable reinforcement service load stress for crack control is:

$$f_{sa} = \frac{Z}{(d_c \cdot A_c)^{\frac{1}{3}}} \quad \text{where} \quad f_{sa} \leq 0.6 \cdot f_y$$

$$f_{sa} = 26.48\text{ksi}$$

$$0.6f_y = 36.00\text{ksi}$$

Use $f_{sa} = 26.48\text{ksi}$

$$E_s = 29000\text{ksi}$$

S5.4.3.2

$$E_c = 3640\text{ksi}$$

S5.4.2.4

$$n = \frac{E_s}{E_c} \quad n = 7.97$$

Use $n = 8$

Service backwall total load moment:

$$M_{ustmservl} = 82.10 \frac{\text{K}\cdot\text{ft}}{\text{ft}}$$

To solve for the actual stress in the reinforcement, the transformed moment of inertia and the distance from the neutral axis to the centroid of the reinforcement must be computed:

$$d_e = 35.44 \text{ in} \quad A_s = \frac{\text{bar_area}}{\text{ft}} \cdot \left(\frac{12 \text{ in}}{\text{bar_space}} \right) \quad A_s = 1.33 \frac{\text{in}^2}{\text{ft}}$$

$$n = 8$$

$$\rho = \frac{A_s}{\frac{b}{\text{ft}} \cdot d_e} \quad \rho = 0.00314$$

$$k = \sqrt{(\rho \cdot n)^2 + (2 \cdot \rho \cdot n)} - \rho \cdot n$$

$$k = 0.200$$

$$k \cdot d_e = 7.10 \text{ in}$$

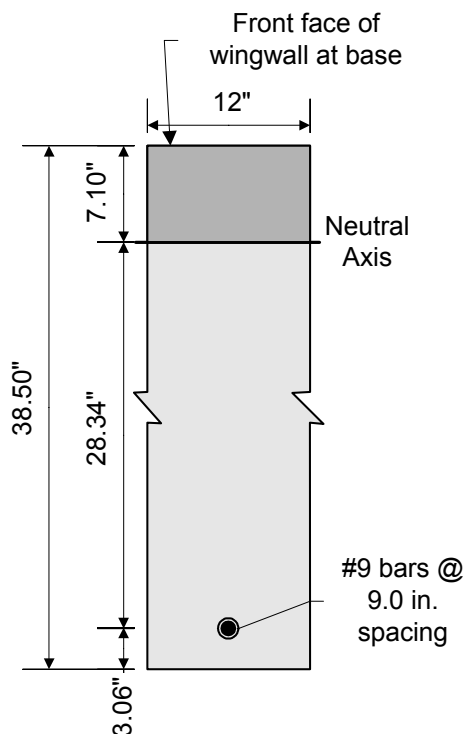

Figure 7-32 Wingwall Crack Control Check

Once kd_e is known, the transformed moment of inertia can be computed:

$$d_e = 35.44 \text{ in}$$

$$A_s = 1.33 \frac{\text{in}^2}{\text{ft}}$$

$$I_t = \frac{1}{3} \cdot \left(12 \frac{\text{in}}{\text{ft}}\right) \cdot (k \cdot d_e)^3 + n \cdot A_s \cdot (d_e - k \cdot d_e)^2$$

$$I_t = 9996.22 \frac{\text{in}^4}{\text{ft}}$$

Now, the actual stress in the reinforcement can be computed:

$$y = d_e - k \cdot d_e \quad y = 28.34 \text{ in}$$

$$f_s = \frac{n \cdot \left(M_{\text{ustmservl}} \cdot 12 \frac{\text{in}}{\text{ft}} \cdot y \right)}{I_t}$$

$$f_s = 22.34 \text{ ksi} \quad f_{sa} > f_s \quad \text{OK}$$

Design for shear:

The factored longitudinal shear force at the base of the wingwall is:

$$V_{\text{Uwwstemdes}} = V_{\text{Uwwstemmax}}$$

$$V_{\text{Uwwstemdes}} = 15.65 \frac{\text{K}}{\text{ft}}$$

The nominal shear resistance is the lesser of:

$$V_{n1} = V_c + V_s$$

or

$$V_{n2} = 0.25 \cdot f_c \cdot b_v \cdot d_v$$

where:

$$V_c = 0.0316 \cdot \beta \cdot \sqrt{f_c} \cdot b_v \cdot d_v$$

and

$$V_s = \frac{A_v \cdot f_y \cdot d_v \cdot (\cot\theta + \cot\alpha) \cdot \sin\alpha}{s}$$

neglect for this wingwall design

S5.8.3.3

Before the nominal shear resistance can be calculated, all the variables used in the above equations need to be defined.

$$\beta = 2.0$$

S5.8.3.4.1

$$b_v = 12 \text{ in}$$

$$d_v = \max\left(d_e - \frac{a}{2}, 0.9 \cdot d_e, 0.72 \cdot h\right)$$

S5.8.2.9

where:

$$d_e = 35.44 \text{ in}$$

$$a = 1.96 \text{ in}$$

$$h = 38.50 \text{ in}$$

Therefore:

$$d_v = 34.46 \text{ in}$$

Now, V_{n1} and V_{n2} can be calculated:

$$\text{For } f_c = 4.0 \text{ ksi}$$

$$V_{n1} = 0.0316 \cdot \beta \cdot \sqrt{f_c} \cdot b_v \cdot d_v$$

$$V_{n1} = 52.27 \frac{\text{K}}{\text{ft}}$$

$$V_{n2} = 0.25 \cdot f_c \cdot b_v \cdot d_v$$

$$V_{n2} = 413.52 \frac{\text{K}}{\text{ft}}$$

$$\text{Use: } V_n = 52.27 \frac{\text{K}}{\text{ft}}$$

The factored shear resistance is then:

$$\phi_v = 0.90$$

S5.5.4.2.1

$$V_r = \phi_v \cdot V_n$$

$$V_r = 47.04 \frac{\text{K}}{\text{ft}}$$

$$V_r > V_{uwwstemdes} \quad \text{OK}$$

Shrinkage and temperature reinforcement:

S5.10.8

For members less than 48.0 inches thick, the area of reinforcement in each direction shall not be spaced greater than 12.0 inches and satisfy the lesser of:

S5.10.8.2

$$A_s \geq 0.11 \frac{A_g}{f_y} \quad \text{or} \quad \Sigma A_b = 0.0015 A_g$$

$$A_g = (38.5 \cdot \text{in}) \cdot \left(12 \cdot \frac{\text{in}}{\text{ft}}\right) \quad A_g = 462.0 \frac{\text{in}^2}{\text{ft}}$$

$$f_y = 60 \text{ ksi}$$

$$0.11 \cdot \frac{A_g}{f_y} = 0.85 \frac{\text{in}^2}{\text{ft}}$$

or

$$0.0015 A_g = 0.69 \frac{\text{in}^2}{\text{ft}}$$

A_s must be greater than or equal to $0.69 \text{ in}^2/\text{ft}$

The above steel must be distributed equally on both faces of the wingwall.

Try 1 horizontal # 5 bar for each face of the wingwall at 9.0 inch spacing:

$$\text{bar_diam} = 0.625 \text{ in}$$

$$\text{bar_area} = 0.31 \text{ in}^2$$

$$A_s = 2 \cdot \frac{\text{bar_area}}{\text{ft}} \cdot \left(\frac{12 \text{ in}}{9 \text{ in}}\right)$$

$$A_s = 0.83 \frac{\text{in}^2}{\text{ft}}$$

$$0.83 \frac{\text{in}^2}{\text{ft}} \geq 0.69 \frac{\text{in}^2}{\text{ft}} \quad \text{OK}$$

Based on the wingwall design, #9 bars at 9.0 inch spacing will be used for the back face flexure reinforcement. Use # 5 bars at 9.0 inch spacing for the front face vertical reinforcement. The horizontal temperature and shrinkage reinforcement will consist of #5 bars at 9.0 inch spacing for the front and back faces.

Design Step 7.12 - Draw Schematic of Final Wingwall Design

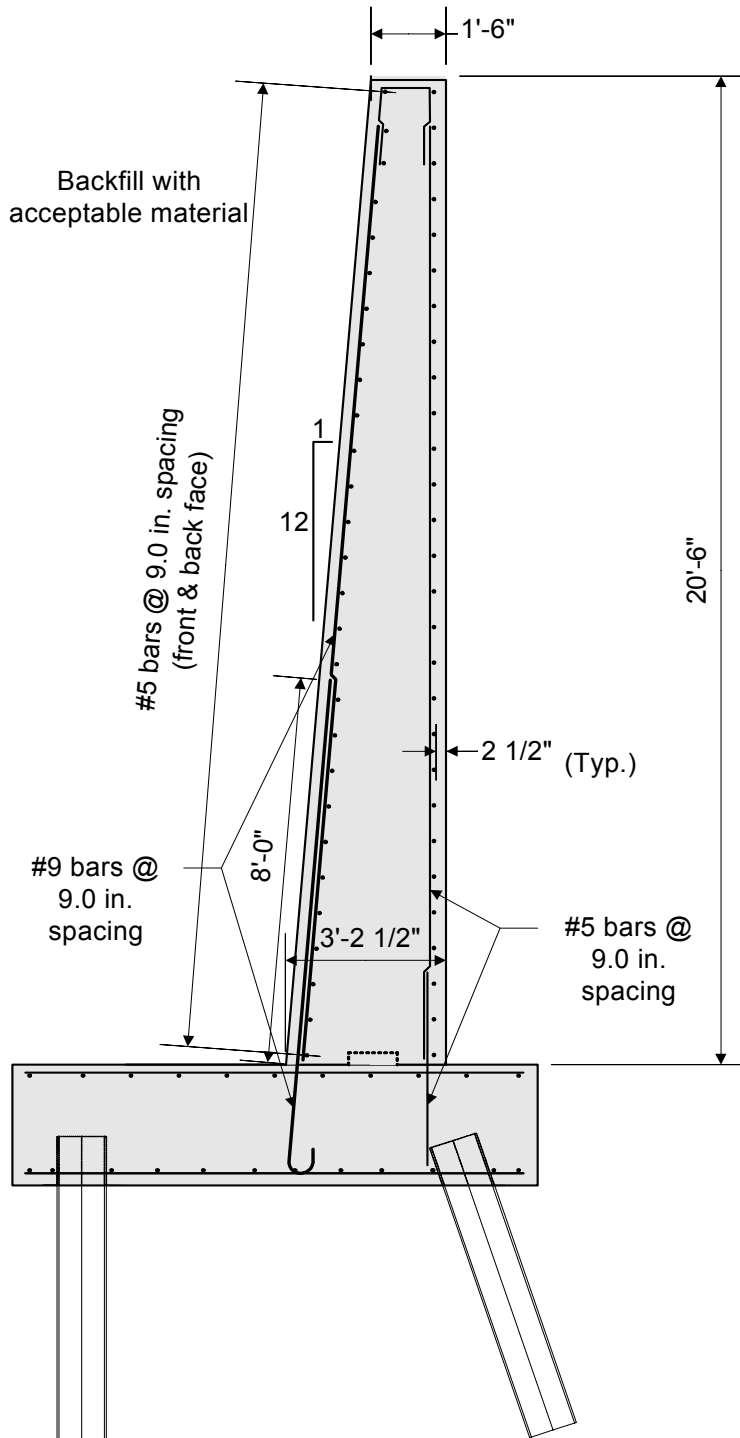

Figure 7-33 Final Wingwall Design

Pier Design Example Design Step 8

Table of Contents

	<u>Page</u>
Design Step 8.1 - Obtain Design Criteria	2
Design Step 8.2 - Select Optimum Pier Type	4
Design Step 8.3 - Select Preliminary Pier Dimensions	5
Design Step 8.4 - Compute Dead Load Effects	6
Design Step 8.5 - Compute Live Load Effects	8
Design Step 8.6 - Compute Other Load Effects	10
Design Step 8.7 - Analyze and Combine Force Effects	24
Design Step 8.8 - Design Pier Cap	39
Design Step 8.9 - Design Pier Column	51
Design Step 8.10 - Design Pier Piles	61
Design Step 8.11 - Design Pier Footing	62
Design Step 8.12 - Final Pier Schematic	69

Design Step 8.1 - Obtain Design Criteria

This pier design example is based on *AASHTO LRFD Bridge Design Specifications* (through 2002 interims). The design methods presented throughout the example are meant to be the most widely used in general bridge engineering practice.

The first design step is to identify the appropriate design criteria. This includes, but is not limited to, defining material properties, identifying relevant superstructure information, determining the required pier height, and determining the bottom of footing elevation.

Refer to Design Step 1 for introductory information about this design example. Additional information is presented about the design assumptions, methodology, and criteria for the entire bridge, including the pier.

The following units are defined for use in this design example:

$$K = 1000\text{lb} \quad \text{kcf} = \frac{K}{\text{ft}^3} \quad \text{ksi} = \frac{K}{\text{in}^2} \quad \text{ksf} = \frac{K}{\text{ft}^2} \quad \text{klf} = \frac{K}{\text{ft}}$$

Material Properties:

Concrete density: $W_c = 0.150\text{kcf}$

*S*Table 3.5.1-1

Concrete 28-day
compressive strength: $f_c = 4.0\text{ksi}$

*S*5.4.2.1

*C*Table 5.4.2.1-1

Reinforcement
strength: $f_y = 60.0\text{ksi}$

*S*5.4.3

Concrete 28-day compressive strength - For all components of this pier design example, 4.0 ksi is used for the 28-day compressive strength. However, per the Specifications, 2.4 ksi could be used for the pier footing.

*C*5.4.2.1

Reinforcing steel cover requirements (assume non-epoxy rebar):

Pier cap: $Cover_{cp} = 2.5in$

STable 5.12.3-1

Pier column: $Cover_{co} = 2.5in$

STable 5.12.3-1

Footing top cover: $Cover_{ft} = 2.0in$

STable 5.12.3-1

Footing bottom cover: $Cover_{fb} = 3.0in$

STable 5.12.3-1

Pier cap and column cover - Since no joint exists in the deck at the pier, a 2-inch cover could be used with the assumption that the pier is not subject to deicing salts. However, it is assumed here that the pier can be subjected to a deicing salt spray from nearby vehicles. Therefore, the cover is set at 2.5 inches.

STable 5.12.3-1

Footing top cover - The footing top cover is set at 2.0 inches.

STable 5.12.3-1

Footing bottom cover - Since the footing bottom is cast directly against the earth, the footing bottom cover is set at 3.0 inches.

STable 5.12.3-1

Relevant superstructure data:

Girder spacing: $S = 9.75ft$

Number of girders: $N = 5$

Deck overhang: $DOH = 3.9375ft$

Span length: $L_{span} = 120.0ft$

Parapet height: $H_{par} = 3.5ft$

Deck overhang thickness: $t_o = 9.0in$

Haunch thickness: $H_{hnch} = 3.5in$ (includes top flange)

Web depth: $D_o = 66.0in$

Bot. flange thickness: $t_{bf} = 2.25in$ (maximum thickness)

Bearing height: $H_{brng} = 5.0in$

Superstructure Depth: $H_{super} = H_{par} + \left(\frac{t_o + H_{hnch} + D_o + t_{bf}}{12 \frac{in}{ft}} \right)$

$H_{super} = 10.23ft$

Superstructure data - The above superstructure data is important because it sets the width of the pier cap and defines the depth and length of the superstructure needed for computation of wind loads.

S3.8

Pier height - Guidance on determining the appropriate pier height can be found in the AASHTO publication *A Policy on Geometric Design of Highways and Streets*. It will be assumed here that adequate vertical clearance is provided given a ground line that is two feet above the top of the footing and the pier dimensions given in Design Step 8.3.

S2.3.3.2

Bottom of Footing Elevation - The bottom of footing elevation may depend on the potential for scour (not applicable in this example) and/or the geotechnical properties of the soil and/or rock. However, as a minimum, it should be at or below the frost depth for a given geographic region. In this example, it is assumed that the two feet of soil above the footing plus the footing thickness provides sufficient depth below the ground line for frost protection of the structure.

S10.6.1.2

Design Step 8.2 - Select Optimum Pier Type

Selecting the most optimal pier type depends on site conditions, cost considerations, superstructure geometry, and aesthetics. The most common pier types are single column (i.e., "hammerhead"), solid wall type, and bent type (multi-column or pile bent). For this design example, a single column (hammerhead) pier was chosen. A typical hammerhead pier is shown in Figure 8-1.

S11.2

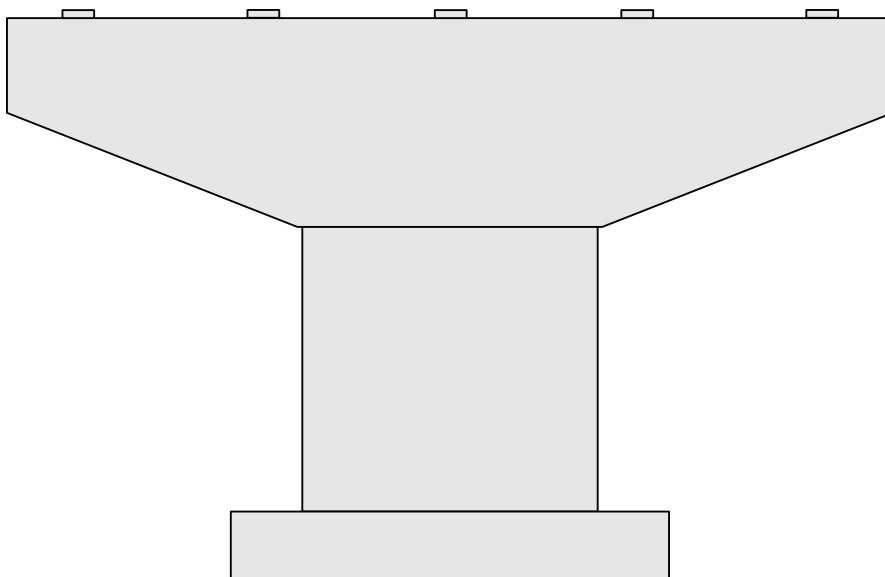

Figure 8-1 Typical Hammerhead Pier

Design Step 8.3 - Select Preliminary Pier Dimensions

Since the Specifications do not have standards regarding maximum or minimum dimensions for a pier cap, column, or footing, the designer should base the preliminary pier dimensions on state specific standards, previous designs, and past experience. The pier cap, however, must be wide enough to accommodate the bearing.

Figures 8-2 and 8-3 show the preliminary dimensions selected for this pier design example.

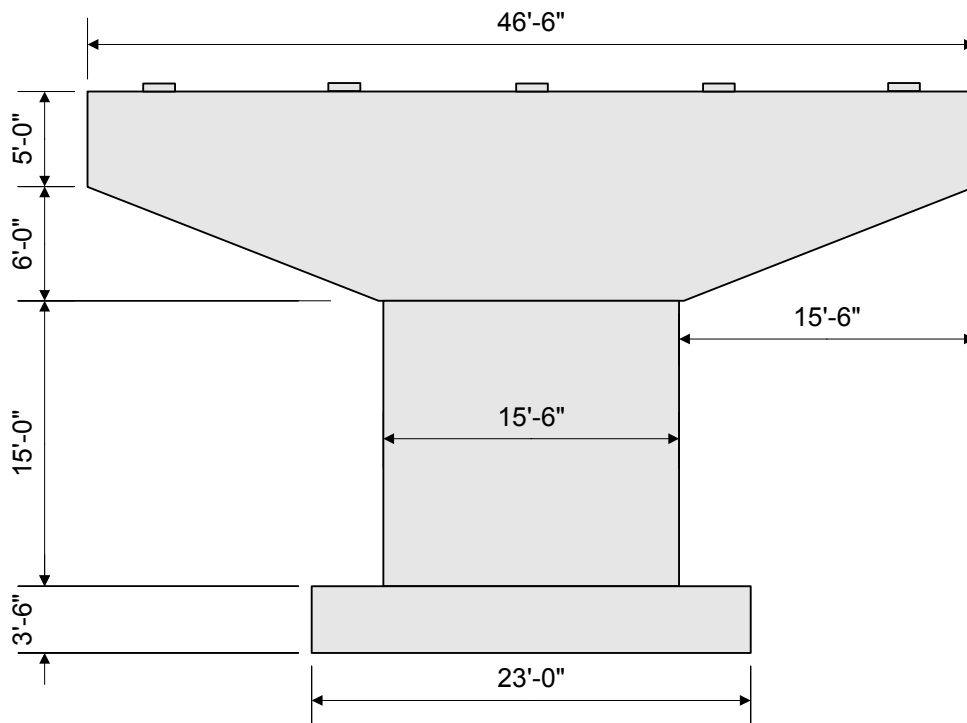

Figure 8-2 Preliminary Pier Dimensions - Front Elevation

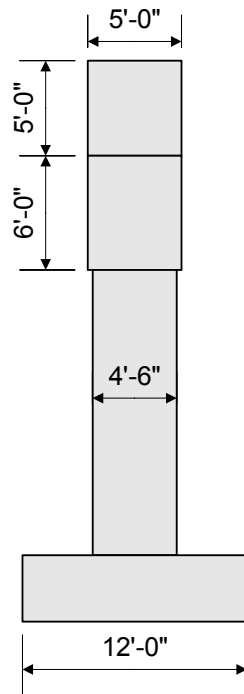

Figure 8-3 Preliminary Pier Dimensions - End Elevation

Design Step 8.4 - Compute Dead Load Effects

Once the preliminary pier dimensions are selected, the corresponding dead loads can be computed. The pier dead loads must then be combined with the superstructure dead loads. The superstructure dead loads shown below are obtained from the superstructure analysis/design software. Based on the properties defined in Design Step 3 (Steel Girder Design), any number of commercially available software programs can be used to obtain these loads. For this design example, the AASHTO Opis software was used, and the values shown below correspond to the first design iteration.

S3.5.1

Exterior girder dead load reactions (DC and DW):

$$R_{DCE} = 253.70K \quad R_{DWE} = 39.20K$$

Interior girder dead load reactions (DC and DW):

$$R_{DCI} = 269.10K \quad R_{DWI} = 39.20K$$

Pier cap dead load:

$$\text{Overhang: } DL_{\text{ovrhg}} = (5\text{ft} \cdot 5\text{ft} \cdot 15.5\text{ft}) \cdot W_C + \frac{1}{2} \cdot (6\text{ft} \cdot 5\text{ft} \cdot 15.5\text{ft}) \cdot W_C$$

$$DL_{\text{ovrhg}} = 93.00 \text{ K}$$

$$\text{Interior: } DL_{\text{int}} = (11\text{ft} \cdot 5\text{ft} \cdot 15.5\text{ft}) \cdot W_C$$

$$DL_{\text{int}} = 127.88 \text{ K}$$

$$\text{Total: } DL_{\text{cap}} = 2 \cdot DL_{\text{ovrhg}} + DL_{\text{int}}$$

$$DL_{\text{cap}} = 313.88 \text{ K}$$

Pier column dead load:

$$DL_{\text{col}} = (15.5\text{ft} \cdot 4.5\text{ft} \cdot 15\text{ft}) \cdot W_C$$

$$DL_{\text{col}} = 156.94 \text{ K}$$

Pier footing dead load:

$$DL_{\text{ftg}} = (3.5\text{ft} \cdot 23\text{ft} \cdot 12\text{ft}) W_C$$

$$DL_{\text{ftg}} = 144.90 \text{ K}$$

In addition to the above dead loads, the weight of the soil on top of the footing must be computed. The two-foot height of soil above the footing was previously defined. Assuming a unit weight of soil at 0.120 kcf :

$$EV_{\text{ftg}} = 0.120\text{kcf} \cdot (2\text{ft}) \cdot (23\text{ft} \cdot 12\text{ft} - 15.5\text{ft} \cdot 4.5\text{ft})$$

$$EV_{\text{ftg}} = 49.50 \text{ K}$$

STable 3.5.1-1

Design Step 8.5 - Compute Live Load Effects

For the pier in this design example, the maximum live load effects in the pier cap, column and footing are based on either one, two or three lanes loaded (whichever results in the worst force effect). Figure 8-4 illustrates the lane positions when three lanes are loaded.

The positioning shown in Figure 8-4 is arrived at by first determining the number of design lanes, which is the integer part of the ratio of the clear roadway width divided by 12 feet per lane. Then the lane loading, which occupies ten feet of the lane, and the HL-93 truck loading, which has a six-foot wheel spacing and a two-foot clearance to the edge of the lane, are positioned within each lane to maximize the force effects in each of the respective pier components.

S3.6.1.1.1
 S3.6.1.2.1
 S3.6.1.2.4
 S3.6.1.3.1

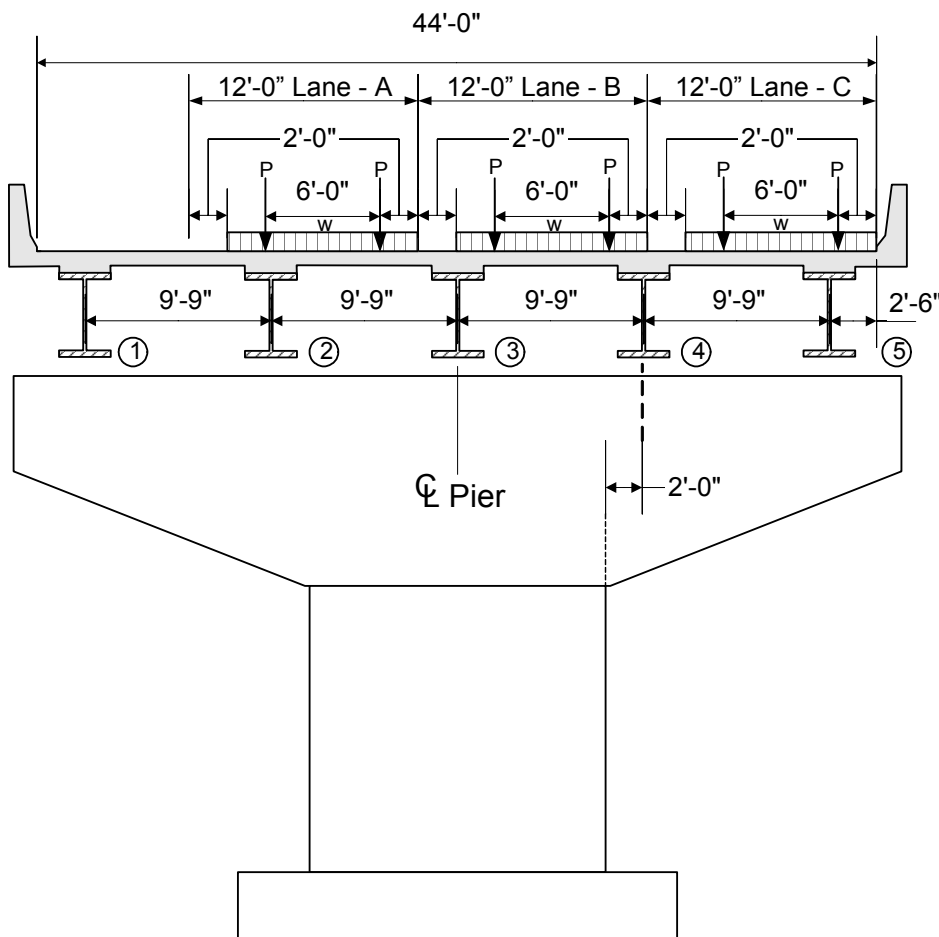

Figure 8-4 Pier Live Loading

The unfactored girder reactions for lane load and truck load are obtained from the superstructure analysis/design software. These reactions do not include dynamic load allowance and are given on a per lane basis (i.e., distribution factor = 1.0). Also, the reactions do not include the ten percent reduction permitted by the Specifications for interior pier reactions that result from longitudinally loading the superstructure with a truck pair in conjunction with lane loading. The value of these reactions from the first design iteration are as follows:

$$R_{\text{truck}} = 124.50\text{K}$$

$$R_{\text{lane}} = 97.40\text{K}$$

Dynamic load allowance, IM

$$IM = 0.33$$

The values of the unfactored concentrated loads which represent the girder truck load reaction per wheel line in Figure 8-4 are:

$$P_{\text{wheel}} = \frac{R_{\text{truck}}}{2} \cdot (1 + IM) \cdot (0.90)$$

$$P_{\text{wheel}} = 74.51\text{K}$$

The value of the unfactored uniformly distributed load which represents the girder lane load reaction in Figure 8-4 is computed next. This load is transversely distributed over ten feet and is not subject to dynamic load allowance.

$$W_{\text{lane}} = \frac{R_{\text{lane}}}{10\text{ft}} \cdot (0.90)$$

$$W_{\text{lane}} = 8.77 \frac{\text{K}}{\text{ft}}$$

The next step is to compute the reactions due to the above loads at each of the five bearing locations. This is generally carried out by assuming the deck is pinned (i.e., discontinuous) at the interior girder locations but continuous over the exterior girders. Solving for the reactions is then elementary. The computations for the reactions with only Lane C loaded are illustrated below as an example. The subscripts indicate the bearing location and the lane loaded to obtain the respective reaction:

$$R_{5_c} = \frac{P_{\text{wheel}} \cdot (4.25\text{ft} + 10.25\text{ft}) + W_{\text{lane}} \cdot 10\text{ft} \cdot 7.25\text{ft}}{9.75\text{ft}}$$

S3.6.1.3.1

STable 3.6.2.1-1

S3.6.2.1

$$R_{5_c} = 176.00K$$

$$R_{4_c} = P_{\text{wheel}} \cdot 2 + W_{\text{lane}} \cdot 10\text{ft} - R_{5_c}$$

$$R_{4_c} = 60.69K$$

The reactions at bearings 1, 2 and 3 with only Lane C loaded are zero. Calculations similar to those above yield the following live load reactions with the remaining lanes loaded (for simplicity, it is assumed that Lane B's loading is resisted entirely, and equally, by bearings 3 and 4):

$$R_{5_a} = 0.0K \quad R_{5_b} = 0.0K$$

$$R_{4_a} = 0.0K \quad R_{4_b} = 118.36K$$

$$R_{3_a} = 70.96K \quad R_{3_b} = 118.36K \quad R_{3_c} = 0.0K$$

$$R_{2_a} = 161.59K \quad R_{2_b} = 0.0K \quad R_{2_c} = 0.0K$$

$$R_{1_a} = 4.19K \quad R_{1_b} = 0.0K \quad R_{1_c} = 0.0K$$

Design Step 8.6 - Compute Other Load Effects

Other load effects that will be considered for this pier design include braking force, wind loads, temperature loads, and earthquake loads.

Braking Force

S3.6.4

Since expansion bearings exist at the abutments, the entire longitudinal braking force is resisted by the pier.

The braking force per lane is the greater of:

25 percent of the axle weights of the design truck or tandem

5 percent of the axle weights of the design truck plus lane load

5 percent of the axle weights of the design tandem plus lane load

The total braking force is computed based on the number of design lanes in the same direction. It is assumed in this example that this bridge is likely to become one-directional in the future. Therefore, any and all design lanes may be used to compute the governing braking force. Also, braking forces are not increased for dynamic load allowance. The calculation of the braking force for a single traffic lane follows:

S3.6.1.1.1

S3.6.2.1

25 percent of the design truck:

$$BRK_{trk} = 0.25 \cdot (32K + 32K + 8K)$$

$$BRK_{trk} = 18.00K$$

25 percent of the design tandem:

$$BRK_{tan} = 0.25 \cdot (25K + 25K)$$

$$BRK_{tan} = 12.50K$$

5 percent of the axle weights of the design truck plus lane load:

$$BRK_{trk_lan} = 0.05 \cdot \left[(32K + 32K + 8K) + \left(0.64 \frac{K}{ft} \cdot 240ft \right) \right]$$

$$BRK_{trk_lan} = 11.28K$$

5 percent of the axle weights of the design tandem plus lane load:

$$BRK_{tan_lan} = 0.05 \cdot \left[(25K + 25K) + \left(0.64 \frac{K}{ft} \cdot 240ft \right) \right]$$

$$BRK_{tan_lan} = 10.18K$$

Use $BRK = \max(BRK_{trk}, BRK_{tan}, BRK_{trk_lan}, BRK_{tan_lan})$

$$BRK = 18.00K$$

The Specifications state that the braking force is applied at a distance of six feet above the roadway surface. However, since the bearings are assumed incapable of transmitting longitudinal moment, the braking force will be applied at the bearing elevation (i.e., five inches above the top of the pier cap). This force may be applied in either horizontal direction (back or ahead station) to cause the maximum force effects. Additionally, the total braking force is typically assumed equally distributed among the bearings:

$$BRK_{brg} = \frac{BRK}{5}$$

S3.6.4

$$BRK_{\text{brg}} = 3.60K$$

Wind Load from Superstructure

Prior to calculating the wind load on the superstructure, the structure must be checked for aeroelastic instability. If the span length to width or depth ratio is greater than 30, the structure is considered wind-sensitive and design wind loads should be based on wind tunnel studies.

$$L_{\text{span}} = 120 \text{ ft}$$

$$\text{Width} = 47 \text{ ft}$$

$$\text{Depth} = H_{\text{super}} - H_{\text{par}}$$

$$\text{Depth} = 6.73 \text{ ft}$$

$$\frac{L_{\text{span}}}{\text{Width}} = 2.55 \quad \text{OK} \quad \frac{L_{\text{span}}}{\text{Depth}} = 17.83 \quad \text{OK}$$

Since the span length to width and depth ratios are both less than 30, the structure does not need to be investigated for aeroelastic instability.

To compute the wind load on the superstructure, the area of the superstructure exposed to the wind must be defined. For this example, the exposed area is the total superstructure depth multiplied by length tributary to the pier. Due to expansion bearings at the abutment, the transverse length tributary to the pier is not the same as the longitudinal length.

The superstructure depth includes the total depth from the top of the barrier to the bottom of the girder. Included in this depth is any haunch and/or depth due to the deck cross-slope. Once the total depth is known, the wind area can be calculated and the wind pressure applied.

The total depth was previously computed in Section 8.1 and is as follows:

$$H_{\text{super}} = 10.23 \text{ ft}$$

For this two-span bridge example, the tributary length for wind load on the pier in the transverse direction is one-half the total length of the bridge:

S3.8.1.2

S3.8.3

S3.8.1.1

$$L_{\text{windT}} = \frac{240}{2} \text{ ft} \quad L_{\text{windT}} = 120 \text{ ft}$$

In the longitudinal direction, the tributary length is the entire bridge length due to the expansion bearings at the abutments:

$$L_{\text{windL}} = 240 \text{ ft}$$

The transverse wind area is:

$$A_{\text{wsuperT}} = H_{\text{super}} \cdot L_{\text{windT}}$$

$$A_{\text{wsuperT}} = 1228 \text{ ft}^2$$

The longitudinal wind area is:

$$A_{\text{wsuperL}} = H_{\text{super}} \cdot L_{\text{windL}}$$

$$A_{\text{wsuperL}} = 2455 \text{ ft}^2$$

Since the superstructure is approximately 30 feet above low ground level, the design wind velocity, V_B , does not have to be adjusted. Therefore:

$$V_B = 100 \text{ mph}$$

$$V_{\text{DZ}} = V_B$$

From this, the design wind pressure is equal to the base wind pressure:

$$P_D = P_B \cdot \left(\frac{V_{\text{DZ}}}{V_B} \right)^2 \quad \text{or} \quad P_D = P_B \cdot \left(\frac{100 \text{ mph}}{100 \text{ mph}} \right)^2$$

$$P_D = P_B$$

Also, the minimum transverse normal wind loading on girders must be greater than or equal to 0.30 KLF:

$$\text{Wind}_{\text{total}} = 0.050 \text{ ksf} \cdot H_{\text{super}}$$

S3.8.1.1

S3.8.1.2.1

S3.8.1.2.1

$Wind_{total} = 0.51 \frac{K}{ft}$, which is greater than 0.30 klf

The wind load from the superstructure acting on the pier depends on the angle of wind direction, or attack angle of the wind. The attack angle is taken as measured from a line perpendicular to the girder longitudinal axis (see Figure 8-5). The base wind pressures for the superstructure for various attack angles are given in STable 3.8.1.2.2-1.

S3.8.1.2.2

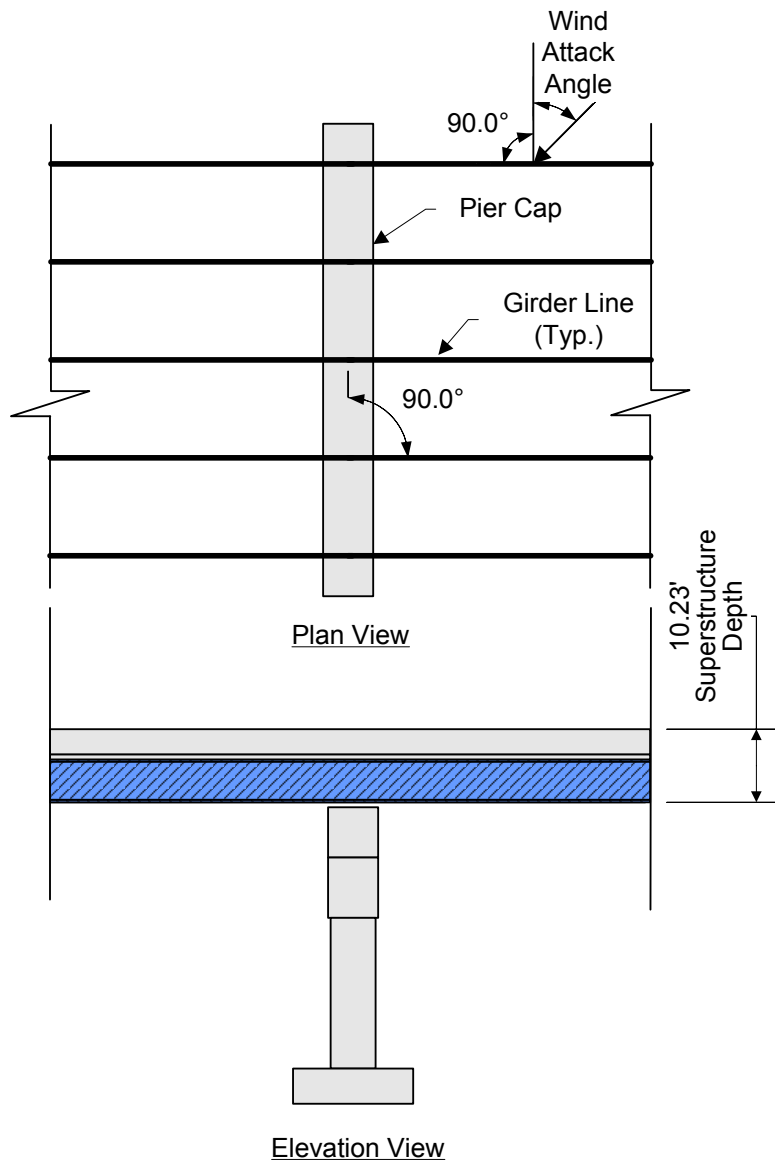

Figure 8-5 Application of Wind Load

Two wind load calculations are illustrated below for two different wind attack angles. The wind loads for all Specifications required attack angles are tabulated in Table 8-1.

For a wind attack angle of 0 degrees, the superstructure wind loads acting on the pier are:

$$WS_{supt\,rns\,0} = A_{w\,super\,T} \cdot 0.050\,ksf$$

$$WS_{supt\,rns\,0} = 61.38\,K$$

$$WS_{supt\,lng\,0} = A_{w\,super\,L} \cdot 0.00\,ksf$$

$$WS_{supt\,lng\,0} = 0.00\,K$$

For a wind attack angle of 60 degrees, the superstructure wind loads acting on the pier are:

$$WS_{supt\,rns\,60} = A_{w\,super\,T} \cdot 0.017\,ksf$$

$$WS_{supt\,rns\,60} = 20.87\,K$$

$$WS_{supt\,lng\,60} = A_{w\,super\,L} \cdot 0.019\,ksf$$

$$WS_{supt\,lng\,60} = 46.65\,K$$

STable 3.8.1.2.2-1

STable 3.8.1.2.2-1

Pier Design Wind Loads from Superstructure		
Wind Attack Angle	Bridge Transverse Axis	Bridge Longitudinal Axis
Degrees	Kips	Kips
0	61.38	0.00
15	54.01	14.73
30	50.33	29.46
45	40.51	39.28
60	20.87	46.65

Table 8-1 Pier Design Wind Loads from Superstructure for Various Wind Attack Angles

The total longitudinal wind load shown above for a given attack angle is assumed to be divided equally among the bearings. In addition, the load at each bearing is assumed to be applied at the top of the bearing (i.e., five inches above the pier cap). These assumptions are consistent with those used in determining the bearing forces due to the longitudinal braking force.

The transverse wind loads shown in Table 8-1 for a given attack angle are also assumed to be equally divided among the bearings and applied at the top of each bearing. However, as shown in Figure 8-6, the transverse load also applies a moment to the pier cap. This moment, which acts about the centerline of the pier cap, induces vertical loads at the bearings as illustrated in Figure 8-6. The computations for these vertical forces with an attack angle of zero are presented below.

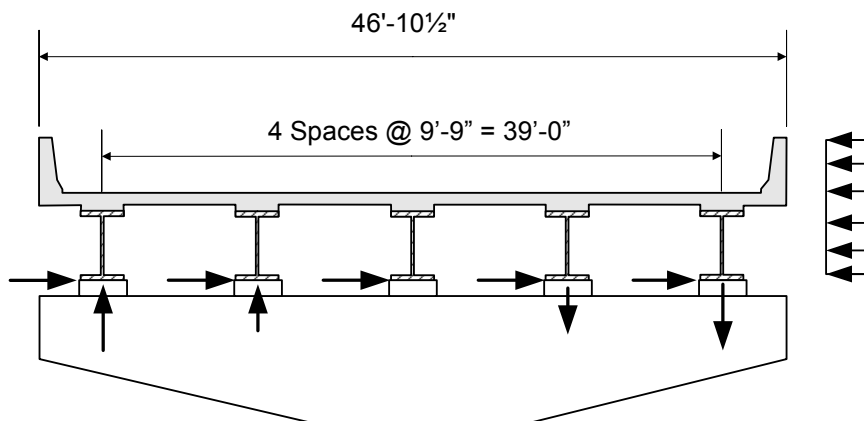

Figure 8-6 Transverse Wind Load Reactions at Pier Bearings from Wind on Superstructure

$$M_{\text{trns0}} = WS_{\text{suptrns0}} \cdot \left(\frac{H_{\text{super}}}{2} \right)$$

$$M_{\text{trns0}} = 313.91 \text{ K}\cdot\text{ft}$$

$$I_{\text{girders}} = 2 \cdot (19.5\text{ft})^2 + 2 \cdot (9.75\text{ft})^2$$

$$I_{\text{girders}} = 950.63 \text{ ft}^2$$

$$RWS1_{5\text{trns0}} = \frac{M_{\text{trns0}} \cdot 19.5\text{ft}}{I_{\text{girders}}}$$

$$RWS1_{5\text{trns0}} = 6.44 \text{ K}$$

The reactions at bearings 1 and 5 are equal but opposite in direction. Similarly for bearings 2 and 4:

$$RWS2_4_{trns0} = \frac{M_{trns0} \cdot 9.75ft}{lgirders}$$

$$RWS2_4_{trns0} = 3.22K$$

Finally, by inspection:

$$RWS3_{trns0} = 0.0K$$

The vertical reactions at the bearings due to transverse wind on the superstructure at attack angles other than zero are computed as above using the appropriate transverse load from Table 8-1. Alternatively, the reactions for other attack angles can be obtained simply by multiplying the reactions obtained above by the ratio of the transverse load at the angle of interest to the transverse load at an attack angle of zero (i.e., 61.38K).

Vertical Wind Load

S3.8.2

The vertical (upward) wind load is calculated by multiplying a 0.020 ksf vertical wind pressure by the out-to-out bridge deck width. It is applied at the windward quarter-point of the deck only for limit states that do not include wind on live load. Also, the wind attack angle must be zero degrees for the vertical wind load to apply.

From previous definitions:

$$\text{Width} = 47.00ft$$

$$L_{windT} = 120.00ft$$

The total vertical wind load is then:

$$WS_{vert} = .02ksf \cdot (\text{Width}) \cdot (L_{windT})$$

$$WS_{vert} = 112.80K$$

This load causes a moment about the pier centerline. The value of this moment is:

$$M_{\text{wind_vert}} = WS_{\text{vert}} \cdot \frac{\text{Width}}{4} \quad M_{\text{wind_vert}} = 1325 \text{ K}\cdot\text{ft}$$

The reactions at the bearings are computed as follows:

$$RWS_{\text{vert1}} = \frac{-WS_{\text{vert}}}{5} + \frac{M_{\text{wind_vert}} \cdot 19.5\text{ft}}{l_{\text{girders}}}$$

$$RWS_{\text{vert2}} = \frac{-WS_{\text{vert}}}{5} + \frac{M_{\text{wind_vert}} \cdot 9.75\text{ft}}{l_{\text{girders}}}$$

$$RWS_{\text{vert3}} = \frac{-WS_{\text{vert}}}{5}$$

$$RWS_{\text{vert4}} = \frac{-WS_{\text{vert}}}{5} - \frac{M_{\text{wind_vert}} \cdot 9.75\text{ft}}{l_{\text{girders}}}$$

$$RWS_{\text{vert5}} = \frac{-WS_{\text{vert}}}{5} - \frac{M_{\text{wind_vert}} \cdot 19.5\text{ft}}{l_{\text{girders}}}$$

The above computations lead to the following values:

$$RWS_{\text{vert1}} = 4.63 \text{ K}$$

$$RWS_{\text{vert2}} = -8.97 \text{ K} \quad (\text{vertically upward})$$

$$RWS_{\text{vert3}} = -22.56 \text{ K} \quad (\text{vertically upward})$$

$$RWS_{\text{vert4}} = -36.15 \text{ K} \quad (\text{vertically upward})$$

$$RWS_{\text{vert5}} = -49.75 \text{ K} \quad (\text{vertically upward})$$

Wind Load on Vehicles

The representation of wind pressure acting on vehicular traffic is given by the Specifications as a uniformly distributed load. Based on the skew angle, this load can act transversely, or both transversely and longitudinally. Furthermore, this load is to be applied at a distance of six feet above the roadway surface. The magnitude of this load with a wind attack angle of zero is 0.10 klf. For wind attack angles other than zero, *S*Table 3.8.1.3-1 gives values for the longitudinal and transverse components. For the transverse and longitudinal loadings, the total force in each respective direction is calculated by multiplying the appropriate component by the length of structure tributary to the pier. Similar to the superstructure wind loading, the longitudinal length tributary to the pier differs from the transverse length.

$$L_{windT} = 120.00 \text{ ft}$$

$$L_{windL} = 240.00 \text{ ft}$$

An example calculation is illustrated below using a wind attack angle of 30 degrees:

$$WL_{trans30} = L_{windT} \cdot (0.082 \cdot \text{klf})$$

$$WL_{trans30} = 9.84 \text{ K}$$

$$WL_{long30} = L_{windL} \cdot (0.024 \text{ klf})$$

$$WL_{long30} = 5.76 \text{ K}$$

S3.8.1.3

*S*Table 3.8.1.3-1

*S*Table 3.8.1.3-1

Table 8-2 contains the total transverse and longitudinal loads due to wind load on vehicular traffic at each Specifications required attack angle.

Wind Attack Angle	Design Vehicular Wind Loads	
	Bridge Transverse Axis	Bridge Longitudinal Axis
	Kips	Kips
0	12.00	0.00
15	10.56	2.88
30	9.84	5.76
45	7.92	7.68
60	4.08	9.12

Table 8-2 Design Vehicular Wind Loads for Various Wind Attack Angles

The vehicular live loads shown in Table 8-2 are applied to the bearings in the same manner as the wind load from the superstructure. That is, the total transverse and longitudinal load is equally distributed to each bearing and applied at the top of the bearing (five inches above the top of the pier cap). In addition, the transverse load acting six feet above the roadway applies a moment to the pier cap. This moment induces vertical reactions at the bearings. The values of these vertical reactions for a zero degree attack angle are given below. The computations for these reactions are not shown but are carried out as shown in the subsection "Wind Load from Superstructure." The only difference is that the moment arm used for calculating the moment is equal to $(H_{\text{super}} - H_{\text{par}} + 6.0 \text{ feet})$.

$$RWL1_{5\text{trns}0} = 3.13\text{K}$$

$$RWL2_{4\text{trns}0} = 1.57\text{K}$$

$$RWL3_{\text{trns}0} = 0.0\text{K}$$

Wind Load on Substructure

The Specifications state that the wind loads acting directly on substructure units shall be calculated from a base wind pressure of 0.040 ksf. It is interpreted herein that this pressure should be applied to the projected area of the pier that is normal to the wind direction. This is illustrated in Figure 8-7. The resulting force is then the product of 0.040 ksf and the projected area. For nonzero wind attack angles, this force is resolved into components applied to the front and end elevations of the pier, respectively. These loads act simultaneously with the superstructure wind loads.

S3.8.1.2.3

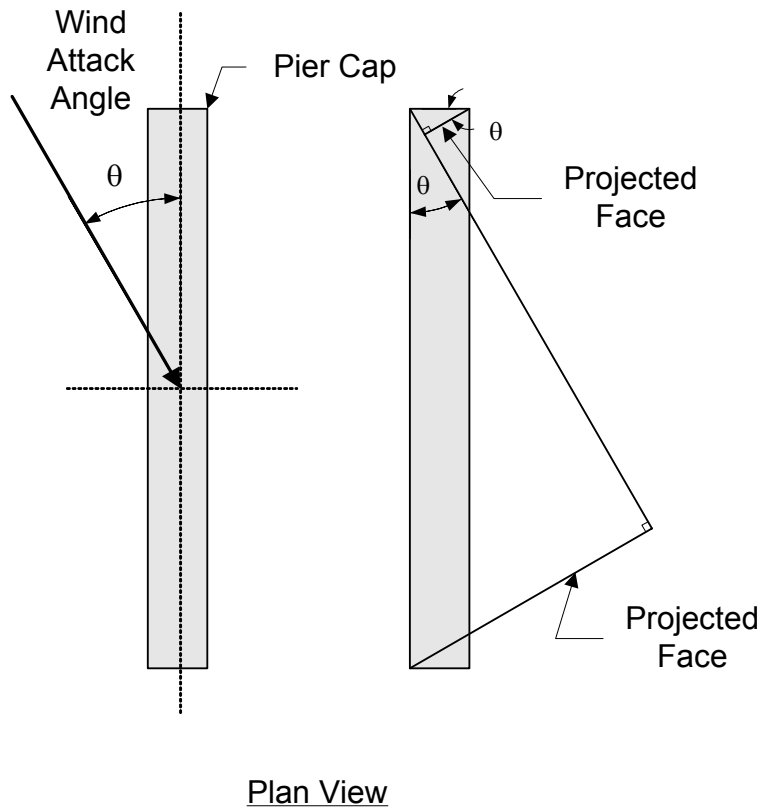

Figure 8-7 Projected Area for Wind Pressure on Pier

What follows is an example of the calculation of the wind loads acting directly on the pier for a wind attack angle of 30 degrees. For simplicity, the tapers of the pier cap overhangs will be considered solid (this is conservative and helpful for wind angles other than zero degrees). The column height exposed to wind is the distance from the ground line (which is two feet above the footing) to the bottom of the pier cap.

Component areas of the pier cap:

$$A_{\text{cap1}} = (11.0\text{ft}) \cdot (5.0\text{ft}) \qquad A_{\text{cap1}} = 55.00\text{ft}^2$$

$$A_{\text{cap2}} = (11.0\text{ft}) \cdot (46.5\text{ft}) \qquad A_{\text{cap2}} = 511.50\text{ft}^2$$

Projected area of pier cap:

$$AP_{cap} = A_{cap1} \cdot \cos(30 \cdot \text{deg}) + A_{cap2} \cdot \sin(30 \cdot \text{deg})$$

$$AP_{cap} = 303.38 \text{ ft}^2$$

Component areas of the pier column:

$$A_{col1} = (15\text{ft} - 2\text{ft}) \cdot (4.5\text{ft}) \quad A_{col1} = 58.50 \text{ ft}^2$$

$$A_{col2} = (15\text{ft} - 2\text{ft}) \cdot (15.5\text{ft}) \quad A_{col2} = 201.50 \text{ ft}^2$$

Projected area of pier column:

$$AP_{col} = A_{col1} \cdot \cos(30 \cdot \text{deg}) + A_{col2} \cdot \sin(30 \cdot \text{deg})$$

$$AP_{col} = 151.41 \text{ ft}^2$$

The total wind force is then:

$$WS_{sub30} = 0.040 \text{ksf} \cdot (AP_{cap} + AP_{col})$$

$$WS_{sub30} = 18.19 \text{ K}$$

The transverse and longitudinal force components are:

$$WS_{sub30T} = WS_{sub30} \cdot \cos(30 \cdot \text{deg})$$

$$WS_{sub30L} = WS_{sub30} \cdot \sin(30 \cdot \text{deg})$$

$$WS_{sub30T} = 15.75 \text{ K}$$

$$WS_{sub30L} = 9.10 \text{ K}$$

The point of application of these loads will be the centroid of the loaded area of each face, respectively. This point will be approximated here as 17 feet above the top of the footing for both the transverse and longitudinal directions.

The wind attack angles for the pier must match the wind attack angles used for the superstructure. Table 8-3 shows the pier wind loads for the various attack angles.

Wind Attack Angle	AP _{cap}	AP _{col}	Total Wind Load	Wind Loads Applied Directly to Pier	
				Trans. Force	Long. Force
Degrees	ft ²	ft ²	Kips	Kips	Kips
0	55.00	58.50	4.54	4.54	0.00
15	185.51	108.66	11.77	11.37	3.05
30	303.38	151.41	18.19	15.75	9.10
45	400.58	183.85	23.38	16.53	16.53
60	470.47	203.75	26.97	13.49	23.36

Table 8-3 Design Wind Loads Applied Directly to Pier for Various Wind Attack Angles

Earthquake Load

It is assumed in this design example that the structure is located in Seismic Zone I with an acceleration coefficient of 0.02. For Seismic Zone I, a seismic analysis is not required. However, the Specifications require a minimum design force for the check of the superstructure to substructure connection. Also, at locations of expansion bearings, a minimum bridge seat must be provided.

Since the bearings at the pier are fixed both longitudinally and transversely, minimum bridge seat requirements for seismic loads are not applicable. Also, since the bearing design is carried out in Design Step 6, the calculations for the check of the connection will not be shown here. Therefore, the earthquake provisions as identified in the above paragraph will have no impact on the overall pier design and will not be discussed further.

S3.10

S4.7.4.1

S3.10.9

S4.7.4.4

Temperature Loading (Superimposed Deformations)

In general, uniform thermal expansion and contraction of the superstructure can impose longitudinal forces on the substructure units. These forces can arise from restraint of free movement at the bearings. Additionally, the physical locations and number of substructure units can cause or influence these forces.

In this particular structure, with a single pier centered between two abutments that have identical bearing types, theoretically no force will develop at the pier from thermal movement of the superstructure. However, seldom are ideal conditions achieved in a physical structure. Therefore, it is considered good practice to include an approximate thermal loading even when theory indicates the absence of any such force.

For the purpose of this design example, a total force of 20 kips will be assumed. This force acts in the longitudinal direction of the bridge (either back or ahead station) and is equally divided among the bearings. Also, the forces at each bearing from this load will be applied at the top of the bearing (i.e., five inches above the pier cap).

$$TU_1 = 4.0K$$

$$TU_2 = 4.0K$$

$$TU_3 = 4.0K$$

$$TU_4 = 4.0K$$

$$TU_5 = 4.0K$$

Design Step 8.7 - Analyze and Combine Force Effects

The first step within this design step will be to summarize the loads acting on the pier at the bearing locations. This is done in Tables 8-4 through 8-15 shown below. Tables 8-4 through 8-8 summarize the vertical loads, Tables 8-9 through 8-12 summarize the horizontal longitudinal loads, and Tables 8-13 through 8-15 summarize the horizontal transverse loads. These loads along with the pier self-weight loads, which are shown after the tables, need to be factored and combined to obtain total design forces to be resisted in the pier cap, column and footing.

S3.12

S3.12.2

STable 3.12.2.1-1

It will be noted here that loads applied due to braking and temperature can act either ahead or back station. Also, wind loads can act on either side of the structure and with positive or negative skew angles. This must be kept in mind when considering the signs of the forces in the tables below. The tables assume a particular direction for illustration only.

Bearing	Superstructure Dead Load		Wearing Surface Dead Load	
	Variable Name	Reaction (Kips)	Variable Name	Reaction (Kips)
1	R _{DCE}	253.70	R _{DWE}	39.20
2	R _{DCI}	269.10	R _{DWI}	39.20
3	R _{DCI}	269.10	R _{DWI}	39.20
4	R _{DCI}	269.10	R _{DWI}	39.20
5	R _{DCE}	253.70	R _{DWE}	39.20

Table 8-4 Unfactored Vertical Bearing Reactions from Superstructure Dead Load

Bearing	Vehicular Live Load **					
	Lane A		Lane B		Lane C	
	Variable Name	Reaction (Kips)	Variable Name	Reaction (Kips)	Variable Name	Reaction (Kips)
1	R _{1_a}	4.19	R _{1_b}	0.00	R _{1_c}	0.00
2	R _{2_a}	161.59	R _{2_b}	0.00	R _{2_c}	0.00
3	R _{3_a}	70.96	R _{3_b}	118.36	R _{3_c}	0.00
4	R _{4_a}	0.00	R _{4_b}	118.36	R _{4_c}	60.69
5	R _{5_a}	0.00	R _{5_b}	0.00	R _{5_c}	176.00

**Note: Live load reactions include impact on truck loading.

Table 8-5 Unfactored Vertical Bearing Reactions from Live Load

Reactions from Transverse Wind Load on Superstructure (kips)					
Wind Attack Angle (degrees)					
Bearing	0	15	30	45	60
1	6.44	5.67	5.28	4.25	2.19
2	3.22	2.83	2.64	2.12	1.09
3	0.00	0.00	0.00	0.00	0.00
4	-3.22	-2.83	-2.64	-2.12	-1.09
5	-6.44	-5.67	-5.28	-4.25	-2.19

Table 8-6 Unfactored Vertical Bearing Reactions from Wind on Superstructure

Reactions from Transverse Wind Load on Vehicular Live Load (kips)					
Wind Attack Angle (degrees)					
Bearing	0	15	30	45	60
1	3.13	2.76	2.57	2.07	1.07
2	1.57	1.38	1.28	1.03	0.53
3	0.00	0.00	0.00	0.00	0.00
4	-1.57	-1.38	-1.28	-1.03	-0.53
5	-3.13	-2.76	-2.57	-2.07	-1.07

Table 8-7 Unfactored Vertical Bearing Reactions from Wind on Live Load

Vertical Wind Load on Superstructure		
Bearing	Variable Name	Reaction (Kips)
1	RWS _{vert1}	4.63
2	RWS _{vert2}	-8.97
3	RWS _{vert3}	-22.56
4	RWS _{vert4}	-36.15
5	RWS _{vert5}	-49.75

Table 8-8 Unfactored Vertical Bearing Reactions from Vertical Wind on Superstructure

Bearing	Braking Load **		Temperature Loading	
	Variable Name	Reaction (Kips)	Variable Name	Reaction (Kips)
1	BRK _{brg}	3.60	TU ₁	4.00
2	BRK _{brg}	3.60	TU ₂	4.00
3	BRK _{brg}	3.60	TU ₃	4.00
4	BRK _{brg}	3.60	TU ₄	4.00
5	BRK _{brg}	3.60	TU ₅	4.00

**Note: Values shown are for a single lane loaded

Table 8-9 Unfactored Horizontal Longitudinal Bearing Reactions from Braking and Temperature

Longitudinal Wind Loads from Superstructure (kips)					
Wind Attack Angle (degrees)					
Bearing	0	15	30	45	60
1	0.00	2.95	5.89	7.86	9.33
2	0.00	2.95	5.89	7.86	9.33
3	0.00	2.95	5.89	7.86	9.33
4	0.00	2.95	5.89	7.86	9.33
5	0.00	2.95	5.89	7.86	9.33
Total =	0.00	14.73	29.46	39.28	46.65

Table 8-10 Unfactored Horizontal Longitudinal Bearing Reactions from Wind on Superstructure

Longitudinal Wind Loads from Vehicular Live Load (kips)					
Wind Attack Angle (degrees)					
Bearing	0	15	30	45	60
1	0.00	0.58	1.15	1.54	1.82
2	0.00	0.58	1.15	1.54	1.82
3	0.00	0.58	1.15	1.54	1.82
4	0.00	0.58	1.15	1.54	1.82
5	0.00	0.58	1.15	1.54	1.82
Total =	0.00	2.88	5.76	7.68	9.12

Table 8-11 Unfactored Horizontal Longitudinal Bearing Reactions from Wind on Live Load

Longitudinal Substructure Wind Loads Applied Directly to Pier (kips)				
Wind Attack Angle (degrees)				
0	15	30	45	60
0.00	3.05	9.10	16.53	23.36

**Table 8-12 Unfactored Horizontal Longitudinal Loads
from Wind Directly on Pier**

Transverse Wind Loads from Superstructure					
Wind Attack Angle					
Bearing	0	15	30	45	60
1	12.28	10.80	10.07	8.10	4.17
2	12.28	10.80	10.07	8.10	4.17
3	12.28	10.80	10.07	8.10	4.17
4	12.28	10.80	10.07	8.10	4.17
5	12.28	10.80	10.07	8.10	4.17
Total =	61.38	54.01	50.33	40.51	20.87

**Table 8-13 Unfactored Horizontal Transverse Bearing
Reactions from Wind on Superstructure**

Transverse Wind Loads from Vehicular Live Load (kips)					
Wind Attack Angle (degrees)					
Bearing	0	15	30	45	60
1	2.40	2.11	1.97	1.58	0.82
2	2.40	2.11	1.97	1.58	0.82
3	2.40	2.11	1.97	1.58	0.82
4	2.40	2.11	1.97	1.58	0.82
5	2.40	2.11	1.97	1.58	0.82
Total =	12.00	10.56	9.84	7.92	4.08

Table 8-14 Unfactored Horizontal Transverse Bearing Reactions from Wind on Live Load

Transverse Substructure Wind Loads Applied Directly to Pier (kips)					
Wind Attack Angle (degrees)					
0	15	30	45	60	
4.54	11.37	15.75	16.53	13.49	

Table 8-15 Unfactored Horizontal Transverse Loads from Wind Directly on Pier

In addition to all the loads tabulated above, the pier self-weight must be considered when determining the final design forces. Additionally for the footing and pile designs, the weight of the earth on top of the footing must be considered. These loads were previously calculated and are shown below:

$$DL_{cap} = 313.88 \text{ K} \quad DL_{ftg} = 144.90 \text{ K}$$

$$DL_{col} = 156.94 \text{ K} \quad EV_{ftg} = 49.50 \text{ K}$$

In the AASHTO LRFD design philosophy, the applied loads are factored by statistically calibrated load factors. In addition to these factors, one must be aware of two additional sets of factors which may further modify the applied loads.

*S*Table 3.4.1-1

*S*Table 3.4.1-2

The first set of additional factors applies to all force effects and are represented by the Greek letter η (eta) in the Specifications. These factors are related to the ductility, redundancy, and operational importance of the structure. A single, combined eta is required for every structure. These factors and their application are discussed in detail in Design Step 1.1. In this design example, all eta factors are taken equal to one.

*S*1.3.2.1

The other set of factors mentioned in the first paragraph above applies only to the live load force effects and are dependent upon the number of loaded lanes. These factors are termed multiple presence factors by the Specifications. These factors for this bridge are shown as follows:

*S*Table 3.6.1.1.2-1

Multiple presence factor, m (1 lane) $m_1 = 1.20$

Multiple presence factor, m (2 lanes) $m_2 = 1.00$

Multiple presence factor, m (3 lanes) $m_3 = 0.85$

Table 8-16 contains the applicable limit states and corresponding load factors that will be used for this pier design. Limit states not shown either do not control the design or are not applicable. The load factors shown in Table 8-16 are the standard load factors assigned by the Specifications and are exclusive of multiple presence and eta factors.

It is important to note here that the maximum load factors shown in Table 8-16 for uniform temperature loading (TU) apply only for deformations, and the minimum load factors apply for all other effects. Since the force effects from the uniform temperature loading are considered in this pier design, the minimum load factors will be used.

*S*3.4.1

Load	Load Factors							
	Strength I		Strength III		Strength V		Service I	
	γ_{max}	γ_{min}	γ_{max}	γ_{min}	γ_{max}	γ_{min}	γ_{max}	γ_{min}
DC	1.25	0.90	1.25	0.90	1.25	0.90	1.00	1.00
DW	1.50	0.65	1.50	0.65	1.50	0.65	1.00	1.00
LL	1.75	1.75	---	---	1.35	1.35	1.00	1.00
BR	1.75	1.75	---	---	1.35	1.35	1.00	1.00
TU	1.20	0.50	1.20	0.50	1.20	0.50	1.20	1.00
WS	---	---	1.40	1.40	0.40	0.40	0.30	0.30
WL	---	---	---	---	1.00	1.00	1.00	1.00
EV	1.35	1.00	1.35	1.00	1.35	1.00	1.00	1.00

STable 3.4.1-1

STable 3.4.1-2

Table 8-16 Load Factors and Applicable Pier Limit States

The loads discussed and tabulated previously can now be factored by the appropriate load factors and combined to determine the governing limit states in the pier cap, column, footing and piles. For this design example, the governing limit states for the pier components were determined from a commercially available pier design computer program. Design calculations will be carried out for the governing limit states only.

Pier Cap Force Effects

The controlling limit states for the design of the pier cap are Strength I (for moment, shear and torsion) and Service I (for crack control). The critical design location is where the cap meets the column, or 15.5 feet from the end of the cap. This is the location of maximum moment, shear, and torsion. The reactions at the two outermost bearings (numbered 4 and 5 in Figure 8-4), along with the self-weight of the cap overhang, cause the force effects at the critical section. In the following calculations, note that the number of lanes loaded to achieve the maximum moment is different than that used to obtain the maximum shear and torsion.

For Strength I, the factored vertical and horizontal forces at the bearings and corresponding force effects at the critical section are shown below. Also shown are the moment arms to the critical section.

Flexure from vertical loads (reference Tables 8-4 and 8-5):

$$FV_{4_{cap_flexstr1}} = 1.25 \cdot R_{DCI} + 1.50 \cdot R_{DWI} + 1.75 \cdot R_{4_c} \cdot m_1$$

$$FV4_{\text{cap_flexstr1}} = 522.62 \text{ K}$$

$$\text{Arm}V4_{\text{cap}} = 2.0 \text{ ft} \quad (\text{see Figure 8-4})$$

$$FV5_{\text{cap_flexstr1}} = 1.25 \cdot R_{\text{DCE}} + 1.50 \cdot R_{\text{DWE}} + 1.75 \cdot R_{5_c} \cdot m_1$$

$$FV5_{\text{cap_flexstr1}} = 745.52 \text{ K}$$

$$\text{Arm}V5_{\text{cap}} = 11.75 \text{ ft}$$

$$\begin{aligned} M_{\text{ucap_str1}} &= FV4_{\text{cap_flexstr1}} \cdot \text{Arm}V4_{\text{cap}} \dots \\ &+ FV5_{\text{cap_flexstr1}} \cdot \text{Arm}V5_{\text{cap}} \dots \\ &+ 1.25 \cdot \text{DL}_{\text{ovrhg}} \cdot \left(\frac{15.5}{2} \text{ ft} \right) \end{aligned}$$

$$M_{\text{ucap_str1}} = 10706 \text{ ft K}$$

Shear from vertical loads (reference Tables 8-4 and 8-5):

$$\begin{aligned} FV4_{\text{cap_shearstr1}} &= 1.25 \cdot R_{\text{DCI}} + 1.50 \cdot R_{\text{DWI}} \dots \\ &+ 1.75 \cdot (R_{4_c} + R_{4_b}) \cdot m_2 \end{aligned}$$

$$FV4_{\text{cap_shearstr1}} = 708.51 \text{ K}$$

$$\begin{aligned} FV5_{\text{cap_shearstr1}} &= 1.25 \cdot R_{\text{DCE}} + 1.50 \cdot R_{\text{DWE}} \dots \\ &+ 1.75 \cdot (R_{5_c} + R_{5_b}) \cdot m_2 \end{aligned}$$

$$FV5_{\text{cap_shearstr1}} = 683.92 \text{ K}$$

$$\begin{aligned} V_{\text{ucap_str1}} &= FV4_{\text{cap_shearstr1}} + FV5_{\text{cap_shearstr1}} \dots \\ &+ 1.25 \cdot \text{DL}_{\text{ovrhg}} \end{aligned}$$

$$V_{\text{ucap_str1}} = 1509 \text{ K}$$

Torsion from horizontal loads (reference Table 8-9):

$$FH4_{cap_torstr1} = 2 \cdot (1.75 \cdot BRK_{brg} \cdot m_2) + 0.50 \cdot TU_4$$

$$FH4_{cap_torstr1} = 14.60K$$

$$FH5_{cap_torstr1} = 2 \cdot (1.75 \cdot BRK_{brg} \cdot m_2) + 0.50 \cdot TU_5$$

$$FH5_{cap_torstr1} = 14.60K$$

$$ArmH_{cap} = \frac{11}{2} \text{ft} + \frac{H_{brng}}{12 \frac{\text{in}}{\text{ft}}}$$

$$ArmH_{cap} = 5.92 \text{ft}$$

$$TU_{cap_str1} = (FH4_{cap_torstr1} + FH5_{cap_torstr1}) \cdot ArmH_{cap}$$

$$TU_{cap_str1} = 172.77 \text{ftK}$$

The applied torsion would be larger than the value just calculated if the vertical loads at the bearings are not coincident with the centerline of the pier cap. Some state agencies mandate a minimum eccentricity to account for this possibility. However, AASHTO does not. Therefore, no eccentricity of vertical loads is considered in this design example.

For Service I, the factored vertical forces at the bearings and corresponding force effects at the critical section are shown next. First, variables for transverse wind load on the structure and on the live load with an attack angle of zero degrees will be defined. Force effects from vertical wind load on the structure are not applicable since the Service I limit state includes wind on live load.

$$RWS5_{trans0} = 6.44K$$

$$RWL5_{trans0} = 3.13K$$

$$RWS4_{trans0} = 3.22K$$

$$RWL4_{trans0} = 1.57K$$

S3.8.2

Flexure from vertical loads (reference Tables 8-4 and 8-5):

$$FV4_{\text{cap_flexser1}} = 1.00 \cdot R_{DCI} + 1.00 \cdot R_{DWI} + 1.00 \cdot R_{4_c} \cdot m_1 \dots \\ + 0.30 \cdot RWS4_{\text{trans0}} + 1.00 \cdot RWL4_{\text{trans0}}$$

$$FV4_{\text{cap_flexser1}} = 383.66 \text{ K}$$

$$\text{Arm}4V = 2.0\text{ft} \quad (\text{see Figure 8-4})$$

$$FV5_{\text{cap_flexser1}} = 1.00 \cdot R_{DCE} + 1.00 \cdot R_{DWE} + 1.00 \cdot R_{5_c} \cdot m_1 \dots \\ + 0.30 \cdot RWS5_{\text{trans0}} + 1.00 \cdot RWL5_{\text{trans0}}$$

$$FV5_{\text{cap_flexser1}} = 509.16 \text{ K}$$

$$\text{Arm}5V = 11.75\text{ft}$$

$$\text{Mu}_{\text{cap_ser1}} = FV4_{\text{cap_flexser1}} \cdot \text{Arm}4V + FV5_{\text{cap_flexser1}} \cdot \text{Arm}5V \dots \\ + 1.00 \cdot DL_{\text{ovrhg}} \cdot \left(\frac{15.5 \text{ ft}}{2} \right)$$

$$\text{Mu}_{\text{cap_ser1}} = 7471 \text{ ftK}$$

Pier Column Force Effects

The controlling limit states for the design of the pier column are Strength I (for biaxial bending with axial load), Strength III (for transverse shear) and Strength V (for longitudinal shear). The critical design location is where the column meets the footing, or at the column base. The governing force effects for Strength I are achieved by excluding the future wearing surface, applying minimum load factors on the structure dead load, and loading only Lane B and Lane C with live load. Transverse and longitudinal shears are maximized with wind attack angles of zero and 60 degrees, respectively.

For Strength I, the factored vertical forces and corresponding moments at the critical section are shown below.

Axial force (reference Tables 8-4 and 8-5):

$$A_{X_{DL_super}} = 0.90 \cdot (2 \cdot R_{DCE} + 3 \cdot R_{DCI})$$

$$A_{X_{DL_super}} = 1183.23 \text{ K}$$

$$A_{X_{DL_sub}} = 0.90 \cdot (DL_{cap} + DL_{col})$$

$$A_{X_{DL_sub}} = 423.73 \text{ K}$$

$$A_{X_{LL}} = 1.75(R_{3_b} + R_{4_b} + R_{4_c} + R_{5_c}) \cdot m_2$$

$$A_{X_{LL}} = 828.46 \text{ K}$$

$$A_{X_{col}} = A_{X_{DL_super}} + A_{X_{DL_sub}} + A_{X_{LL}}$$

$$A_{X_{col}} = 2435 \text{ K}$$

Transverse moment (reference Table 8-5):

$$Arm_{V4_{col}} = 9.75 \text{ ft}$$

$$Arm_{V5_{col}} = 19.5 \text{ ft}$$

$$Mut_{col} = 1.75(R_{4_b} + R_{4_c}) \cdot m_2 \cdot Arm_{V4_{col}} \dots \\ + 1.75 \cdot (R_{5_c}) \cdot m_2 \cdot Arm_{V5_{col}}$$

$$Mut_{col} = 9061 \text{ ft K}$$

Longitudinal moment (reference Table 8-9):

$$Arm_{H_{col_sup}} = 15 \text{ ft} + 11 \text{ ft} + \frac{H_{brng}}{12 \frac{\text{in}}{\text{ft}}}$$

$$Arm_{H_{col_sup}} = 26.42 \text{ ft}$$

$$M_{ul\text{col}} = 5 \cdot (1.75 \cdot BRK_{\text{brg}} \cdot \text{ArmH}_{\text{col_sup}}) \cdot 2 \cdot m_2 \dots \\ + 0.50 \left(\begin{array}{l} TU_1 + TU_2 \dots \\ + TU_3 + TU_4 + TU_5 \end{array} \right) \cdot \text{ArmH}_{\text{col_sup}}$$

$$M_{ul\text{col}} = 1928 \text{ ftK}$$

For Strength III, the factored transverse shear in the column is:

$$WS_{\text{supt}rs0} = 61.38 \text{ K} \quad WS_{\text{sub}0T} = 4.54 \text{ K}$$

$$V_{ut\text{col}} = 1.40(WS_{\text{supt}rs0} + WS_{\text{sub}0T})$$

$$V_{ut\text{col}} = 92.28 \text{ K}$$

For Strength V, the factored longitudinal shear in the column is (reference Table 8-9):

$$WS_{\text{sup}l\text{ng}60} = 46.65 \text{ K} \quad WS_{\text{sub}60L} = 23.36 \text{ K}$$

$$WL_{\text{long}60} = 9.12 \text{ K}$$

$$V_{ul\text{col}} = 0.40(WS_{\text{sup}l\text{ng}60} + WS_{\text{sub}60L}) + 1.00 \cdot WL_{\text{long}60} \dots \\ + 0.50 \cdot (TU_1 + TU_2 + TU_3 + TU_4 + TU_5) \dots \\ + 1.35 \cdot (5 \cdot BRK_{\text{brg}}) \cdot 3 \cdot m_3$$

$$V_{ul\text{col}} = 109.09 \text{ K}$$

Pier Pile Force Effects

The foundation system for the pier is a reinforced concrete footing on steel H-piles. The force effects in the piles cannot be determined without a pile layout. The pile layout depends upon the pile capacity and affects the footing design. The pile layout used for this pier foundation is shown in Design Step 8.10 (Figure 8-11).

Based on the pile layout shown in Figure 8-11, the controlling limit states for the pile design are Strength I (for maximum pile load), Strength III (for minimum pile load), and Strength V (for maximum horizontal loading of the pile group).

The force effects in the piles for the above-mentioned limit states are not given. The reason for this is discussed in Design Step 8.10.

Pier Footing Force Effects

The controlling limit states for the design of the pier footing are Strength I (for flexure, punching shear at the column, and punching shear at the maximum loaded pile), Strength IV (for one-way shear), and Service I (for crack control). There is not a single critical design location in the footing where all of the force effects just mentioned are checked. Rather, the force effects act at different locations in the footing and must be checked at their respective locations. For example, the punching shear checks are carried out using critical perimeters around the column and maximum loaded pile, while the flexure and one-way shear checks are carried out on a vertical face of the footing either parallel or perpendicular to the bridge longitudinal axis.

The Strength I limit state controls for the punching shear check at the column. The factored axial load and corresponding factored biaxial moments at the base of the column are obtained in a manner similar to that for the Strength I force effects in the pier column. However, in this case the future wearing surface is now included, maximum factors are applied to all the dead load components, and all three lanes are loaded with live load. This results in the following bottom of column forces:

$$A_{x_{col_punch}} = 3583K$$

$$M_{ut_{col_punch}} = 5287ft \cdot K$$

$$M_{ul_{col_punch}} = 2756ft \cdot K$$

Factored force effects for the remaining limit states discussed above are not shown. The reason for this is discussed in Design Step 8.11.

Design Step 8.8 - Design Pier Cap

Prior to carrying out the actual design of the pier cap, a brief discussion is in order regarding the design philosophy that will be used for the design of the structural components of this pier.

When a structural member meets the definition of a deep component, the Specifications recommends, although does not mandate, that a strut-and-tie model be used to determine force effects and required reinforcing. Specifications Commentary *C5.6.3.1* indicates that a strut-and-tie model properly accounts for nonlinear strain distribution, nonuniform shear distribution, and the mechanical interaction of V_u , T_u and M_u . Use of strut-and-tie models for the design of reinforced concrete members is new to the LRFD Specification.

S5.2

S5.6.3.1

Traditionally, piers have been designed using conventional methods of strength of materials regardless of member dimensions. In this approach, it is assumed that longitudinal strains vary linearly over the depth of the member and the shear distribution remains uniform. Furthermore, separate designs are carried out for V_u and M_u at different locations along the member.

C5.6.3.1

For the purpose of this design example, all structural components, regardless of dimensions, will be designed in accordance with the conventional strength of materials assumptions described above. This approach is currently standard engineering practice.

The design of the pier cap will now proceed.

As stated in Design Step 8.7, the critical section in the pier cap is where the cap meets the column, or 15.5' from the end of the cap. The governing force effects and their corresponding limit states were determined to be:

Strength I

$$M_{u_{cap_str1}} = 10706 \text{ ftK}$$

$$V_{u_{cap_str1}} = 1509 \text{ K}$$

$$T_{u_{cap_str1}} = 172.77 \text{ ftK}$$

Service I

$$M_{u_{cap_ser1}} = 7471 \text{ ftK}$$

A preliminary estimate of the required section size and reinforcement is shown in Figure 8-8.

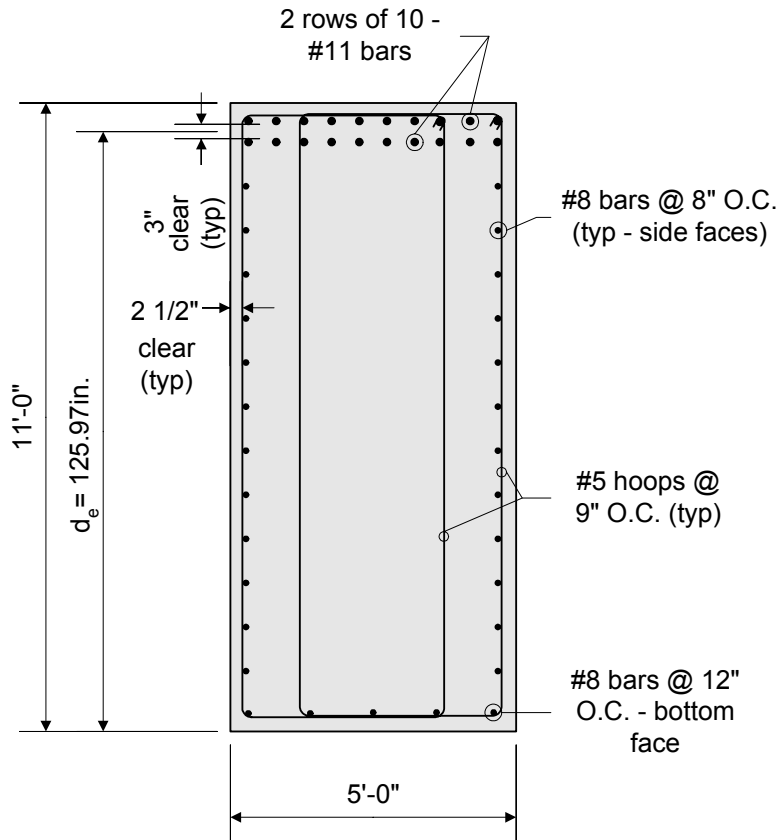

Figure 8-8 Preliminary Pier Cap Design

Design for Flexure (Strength I)

Assume #11 bars:

$$\text{bar_diam11} = 1.41\text{in}$$

$$\text{bar_area11} = 1.56\text{in}^2$$

$$f_y = 60\text{ksi}$$

The minimum reinforcement requirements will be calculated for the cap. The tensile reinforcement provided must be enough to develop a factored flexural resistance at least equal to the lesser of 1.2 times the cracking strength or 1.33 times the factored moment from the applicable strength load combinations.

S5.7.3.3.2

The cracking strength is calculated as follows:

$$f_r = 0.24 \cdot \sqrt{f_c}$$

$$f_r = 0.48 \text{ ksi}$$

$$I_g = \frac{1}{12} (60 \text{ in}) (132 \text{ in})^3$$

$$I_g = 11499840 \text{ in}^4$$

$$y_t = 66 \text{ in}$$

$$M_{Cr} = \frac{f_r \cdot I_g}{y_t} \cdot \frac{1}{12} \frac{\text{in}}{\text{ft}}$$

$$M_{Cr} = 6970 \text{ ft K}$$

$$1.2 \cdot M_{Cr} = 8364 \text{ ft K}$$

By inspection, the applied moment from the Strength I limit state exceeds 120 percent of the cracking moment. Therefore, providing steel sufficient to resist the applied moment automatically satisfies the minimum reinforcement check.

The effective depth (d_e) of the section shown in Figure 8-8 is computed as follows:

$$\text{Cover}_{cp} = 2.50 \text{ in}$$

$$d_e = 132 \text{ in} - \left(\text{Cover}_{cp} + .625 \text{ in} + 1.41 \text{ in} + \frac{3}{2} \text{ in} \right)$$

$$d_e = 125.97 \text{ in}$$

Solve for the required amount of reinforcing steel, as follows:

$$\phi_f = 0.90$$

$$b = 60 \text{ in}$$

$$f_c = 4.0 \text{ ksi}$$

S5.4.2.6

S5.5.4.2.1

$$M_{u_{cap_str1}} = 10706 \text{ ftK}$$

$$R_n = \frac{M_{u_{cap_str1}} \cdot 12 \frac{\text{in}}{\text{ft}}}{(\phi_f \cdot b \cdot d_e^2)} \quad R_n = 0.15 \text{ ksi}$$

$$\rho = 0.85 \left(\frac{f_c}{f_y} \right) \left[1.0 - \sqrt{1.0 - \frac{(2 \cdot R_n)}{(0.85 \cdot f_c)}} \right]$$

$$\rho = 0.00256$$

The above two equations are derived formulas that can be found in most reinforced concrete textbooks.

$$A_s = \rho \cdot b \cdot d_e \quad A_s = 19.32 \text{ in}^2$$

The area of steel provided is:

$$A_{s_cap} = 20 \cdot (\text{bar_area11})$$

$$A_{s_cap} = 31.20 \text{ in}^2$$

$$A_{s_cap} \geq A_s \quad \text{OK}$$

The reinforcement area provided must now be checked to ensure that the section is not overreinforced:

S5.7.3.3.1

$$T = A_{s_cap} \cdot f_y \quad T = 1872.00 \text{ K}$$

$$a = \frac{T}{0.85 \cdot f_c \cdot b} \quad a = 9.18 \text{ in}$$

$$\beta_1 = 0.85$$

S5.7.2.2

$$c = \frac{a}{\beta_1} \quad c = 10.80 \text{ in}$$

S5.7.2.2

$$\frac{c}{d_e} = 0.09 \quad \text{where} \quad \frac{c}{d_e} \leq 0.42$$

S5.7.3.3.1

$$0.09 \leq 0.42 \quad \text{OK}$$

Design for Flexure (Service I)

The control of cracking by distribution of reinforcement must be satisfied.

S5.7.3.4

Since this design example assumes that the pier cap will be exposed to deicing salts, use:

$$Z = 130 \frac{\text{K}}{\text{in}}$$

The distance from the extreme tension fiber to the center of the closest bar, using a maximum cover dimension of 2 inches, is:

$$d_c = 2.0\text{in} + 0.625\text{in} + \frac{\text{bar_diam11}}{2}$$

$$d_c = 3.33\text{in}$$

The area of concrete having the same centroid as the principal tensile reinforcement and bounded by the surfaces of the cross-section and a straight line parallel to the neutral axis, divided by the number of bars, is:

$$A_c = \frac{2 \cdot \left(d_c + \frac{\text{bar_diam11}}{2} + \frac{3\text{in}}{2} \right) \cdot b}{20}$$

$$A_c = 33.21 \text{ in}^2$$

The equation that gives the allowable reinforcement service load stress for crack control is:

$$f_{sa} = \frac{Z}{(d_c \cdot A_c)^{\frac{1}{3}}} \quad \text{where} \quad f_{sa} \leq 0.6 \cdot f_y$$

S5.7.3.4

$$f_{sa} = 27.08 \text{ ksi}$$

$$0.6f_y = 36.00 \text{ ksi}$$

Use $f_{sa} = 27.08 \text{ ksi}$

$$E_s = 29000 \text{ ksi}$$

S5.4.3.2

$$E_c = 3640 \text{ ksi}$$

SEquation
C5.4.2.4-1

$$n = \frac{E_s}{E_c} \quad n = 7.97 \quad \text{Use } n = 8$$

The factored service moment in the cap is:

$$M_{u_{cap_ser1}} = 7471 \text{ ftK}$$

To solve for the actual stress in the reinforcement, the distance from the neutral axis to the centroid of the reinforcement (see Figure 8-9) and the transformed moment of inertia must be computed:

$$n = 8$$

$$d_e = 125.97 \text{ in}$$

$$A_{s_cap} = 31.20 \text{ in}^2$$

$$\rho = \frac{A_{s_cap}}{b \cdot d_e}$$

$$\rho = 0.00413$$

$$k = \sqrt{(\rho \cdot n)^2 + (2 \cdot \rho \cdot n)} - \rho \cdot n$$

$$k = 0.226$$

$$k \cdot d_e = 28.48 \text{ in}$$

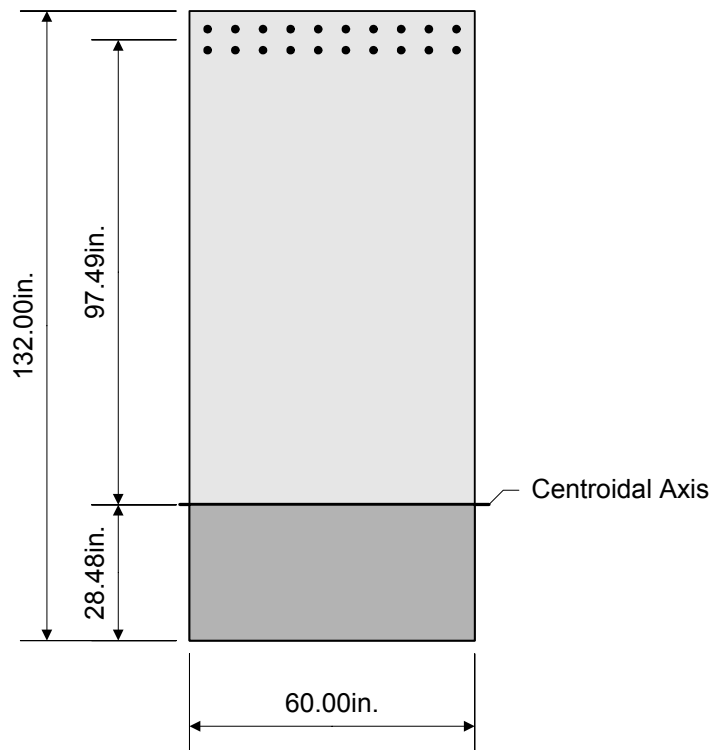

Figure 8-9 Pier Cap Under Service Loads

Once $k d_e$ is known, the transformed moment of inertia can be computed:

$$d_e = 125.97 \text{ in}$$

$$A_{s_cap} = 31.20 \text{ in}^2$$

$$I_t = \frac{1}{3} \cdot (60 \text{ in}) \cdot (k \cdot d_e)^3 + n \cdot A_{s_cap} \cdot (d_e - k \cdot d_e)^2$$

$$I_t = 2834038 \text{ in}^4$$

Now, the actual stress in the reinforcement is computed:

$$M_{u_{cap_ser1}} = 7471 \text{ ftK}$$

$$y = d_e - k \cdot d_e \qquad y = 97.49 \text{ in}$$

$$f_s = \frac{\left(M_{u_{cap_ser1}} \cdot 12 \frac{\text{in}}{\text{ft}} \cdot y \right)}{I_t} \cdot n$$

$$f_s = 24.67 \text{ ksi}$$

$$f_{sa} = 27.08 \text{ ksi}$$

$$f_{sa} > f_s \quad \text{OK}$$

Design for Flexure (Skin Reinforcement)

S5.7.3.4

In addition to the above check for crack control, additional longitudinal steel must be provided along the side faces of concrete members deeper than three feet. This additional steel is referred to in the Specifications as longitudinal skin reinforcement. This is also a crack control check. However, this check is carried out using the effective depth (d_e) and the required longitudinal tension steel in place of specific applied factored loads.

Figure 8-8 shows longitudinal skin reinforcement (#8 bars spaced at 8" on center) over the entire depth of the pier cap at the critical section. The Specifications require this steel only over a distance $d_e/2$ from the nearest flexural tension reinforcement. However, the reinforcing bar arrangement shown in Figure 8-8 is considered good engineering practice. This includes the placement of reinforcing steel along the bottom face of the pier cap as well, which some state agencies mandate.

The calculations shown below are for the critical section in the pier cap. The skin reinforcement necessary at this section is adequate for the entire pier cap.

$$d_e = 125.97 \text{ in} \quad A_{s_cap} = 31.20 \text{ in}^2$$

$$\text{bar_area8} = 0.79 \text{ in}^2$$

$$A_{sk} \geq 0.012 \cdot (d_e - 30) \quad \text{and} \quad A_{sk} \leq \frac{A_s}{4}$$

SEquation
5.7.3.4-4

$$A_{sk} = 0.012 \cdot (125.97 - 30) \frac{\text{in}^2}{\text{ft}}$$

$$A_{sk} = 1.15 \frac{\text{in}^2}{\text{ft}} \quad (\text{each side face})$$

$$\left(\frac{31.2}{4} \right) \cdot \frac{\text{in}^2}{\text{ft}} = 7.80 \frac{\text{in}^2}{\text{ft}}$$

$$A_{sk} \leq 7.8 \frac{\text{in}^2}{\text{ft}} \quad \text{OK}$$

Spacing of the skin reinforcement:

$$S_{Ask} = \min\left(\frac{d_e}{6}, 12\text{in}\right)$$

$$S_{Ask} = 12.00\text{in}$$

Verify that #8 bars at 8" on center is adequate:

$$\text{bar_area}_8 \cdot \left(\frac{12}{8}\right) \cdot \frac{1}{\text{ft}} = 1.18 \frac{\text{in}^2}{\text{ft}}$$

$$1.18 \frac{\text{in}^2}{\text{ft}} \geq A_{sk} \quad \text{OK}$$

Design for Shear and Torsion (Strength I)

S5.8

The shear and torsion force effects were computed previously and are:

$$V_{u\text{cap_str1}} = 1509\text{K}$$

$$T_{u\text{cap_str1}} = 172.77\text{ftK}$$

The presence of torsion affects the total required amount of both longitudinal and transverse reinforcing steel. However, if the applied torsion is less than one-quarter of the factored torsional cracking moment, then the Specifications allow the applied torsion to be ignored. This computation is shown as follows:

S5.8.2.1

$$\phi_t = 0.90$$

S5.5.4.2.1

$$A_{cp} = (60\text{in}) \cdot (132\text{in})$$

$$A_{cp} = 7920\text{in}^2$$

$$P_c = 2 \cdot (60\text{in} + 132\text{in})$$

$$P_c = 384.00 \text{ in} \qquad \sqrt{4}(1 \cdot \text{ksi}) = 2.00 \text{ ksi}$$

$$T_{cr} = .125(2 \text{ ksi}) \cdot \frac{(A_{cp})^2}{P_c} \cdot \left(\frac{1}{12 \frac{\text{in}}{\text{ft}}} \right)$$

$$T_{cr} = 3403 \text{ ft K}$$

$$0.25 \cdot \phi_t \cdot T_{cr} = 765.70 \text{ ft K}$$

$$T_{U_{cap_str1}} < 0.25 \cdot \phi_t \cdot T_{cr}$$

Based on the above check, torsion will be neglected and will not be discussed further. The shear check of the critical cap section will now proceed.

The nominal shear resistance of the critical section is a combination of the nominal resistance of the concrete and the nominal resistance of the steel. This value is then compared to a computed upper-bound value and the lesser of the two controls. These calculations are illustrated below:

$$b_v = 60 \text{ in} \qquad h = 132 \cdot \text{in}$$

$$d_v = \max\left(d_e - \frac{a}{2}, 0.9 \cdot d_e, 0.72 \cdot h\right)$$

$$d_v = 121.38 \text{ in}$$

$$\beta = 2.0 \qquad \theta = 45 \text{ deg}$$

The nominal concrete shear strength is:

$$\sqrt{4}(1 \cdot \text{ksi}) = 2.00 \text{ ksi}$$

$$V_c = 0.0316 \cdot \beta \cdot (2 \text{ ksi}) \cdot b_v \cdot d_v$$

$$V_c = 920.52 \text{ K}$$

Note that unless one-half of the product of V_c and the phi-factor for shear is greater than V_u , then transverse reinforcement must be provided. Therefore, when V_c is less than V_u , as in this case, transverse reinforcement is automatically required.

S5.8.3.3

S5.8.2.9

S5.8.3.4.1

S5.8.3.3

S5.8.2.4

The nominal steel shear strength is (using vertical stirrups, theta equal to 45 degrees):

$$A_v = 1.24\text{in}^2 \quad (4 \text{ legs of \#5 bars})$$

$$s = 9\text{in}$$

$$V_s = \frac{A_v \cdot f_y \cdot d_v}{s}$$

$$V_s = 1003\text{K}$$

S5.8.3.3

The nominal shear strength of the critical section is the lesser of the following two values:

$$V_{n1} = V_c + V_s \quad V_{n1} = 1924\text{K} \quad (\text{controls})$$

$$V_{n2} = 0.25 \cdot f_c \cdot b_v \cdot d_v \quad V_{n2} = 7283\text{K}$$

S5.8.3.3

Define V_n as follows:

$$V_n = V_{n1} \quad V_n = 1924\text{K}$$

The factored shear resistance is:

$$\phi_v = 0.90$$

$$V_r = \phi_v \cdot V_n$$

$$V_r = 1732\text{K}$$

$$V_r > V_{u\text{cap_str1}} \quad \text{OK}$$

S5.5.4.2.1

The shear check is not complete until the provided transverse steel is compared to the Specifications requirements regarding minimum quantity and maximum spacing.

Minimum quantity required:

$$\sqrt{4}(1 \cdot \text{ksi}) = 2.00\text{ksi}$$

S5.8.2.5

$$A_{v_min} = 0.0316 \cdot (2.0 \text{ ksi}) \cdot \frac{b_v \cdot s}{f_y}$$

$$A_{v_min} = 0.57 \text{ in}^2$$

$$A_v > A_{v_min} \quad \text{OK}$$

Maximum spacing allowed:

$$V_{u_cap_str1} = 1509 \text{ K}$$

$$v_{u_stress} = \frac{V_{u_cap_str1}}{(\phi_v) \cdot (b_v) \cdot (d_v)}$$

$$v_{u_stress} = 0.23 \text{ ksi}$$

$$0.125 \cdot f_c = 0.50 \text{ ksi}$$

$$v_{u_stress} < 0.50 \text{ ksi}$$

$$s_{stress} = 0.8 \cdot (d_v)$$

$$s_{stress} = 97.10 \text{ in}$$

$$s_{max} = \min(s_{stress}, 24 \text{ in})$$

$$s_{max} = 24.00 \text{ in}$$

$$s \leq s_{max} \quad \text{OK}$$

S5.8.2.7

S5.8.2.9

Design Step 8.9 - Design Pier Column

As stated in Design Step 8.7, the critical section in the pier column is where the column meets the footing, or at the column base. The governing force effects and their corresponding limit states were determined to be:

Strength I

$$Ax_{col} = 2435 \text{ K}$$

$$Mut_{col} = 9061 \text{ ft K}$$

$$Mul_{col} = 1928 \text{ ft K}$$

Strength III

$$Vut_{col} = 92.28 \text{ K}$$

Strength V

$$Vul_{col} = 109.09 \text{ K}$$

A preliminary estimate of the required section size and reinforcement is shown in Figure 8-10.

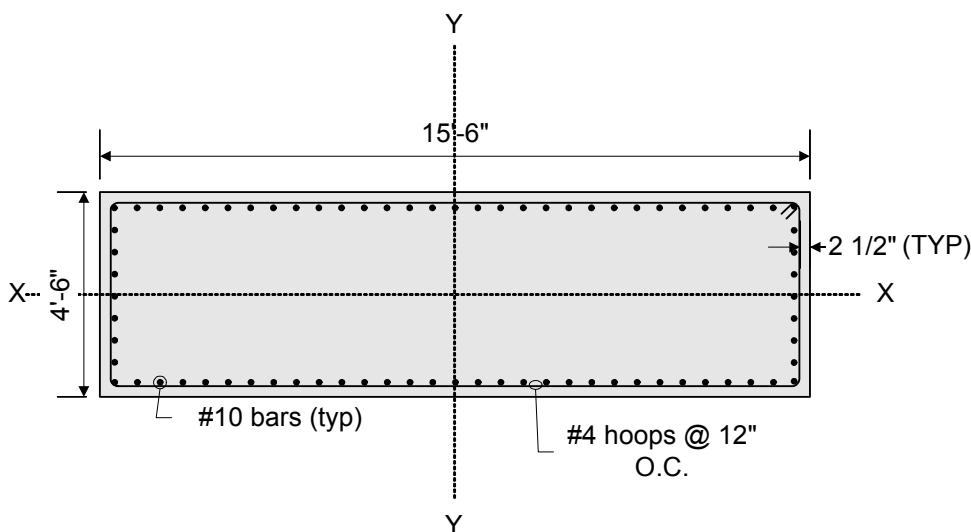

Figure 8-10 Preliminary Pier Column Design

Design for Axial Load and Biaxial Bending (Strength I):

S5.7.4

The preliminary column reinforcing is shown in Figure 8-10 and corresponds to #10 bars equally spaced around the column perimeter. The Specifications prescribe limits (both maximum and minimum) on the amount of reinforcing steel in a column. These checks are performed on the preliminary column as follows:

S5.7.4.2

$$\text{Num_bars} = 76 \qquad \text{bar_area10} = 1.27\text{in}^2$$

$$A_{s_col} = (\text{Num_bars}) \cdot (\text{bar_area10})$$

$$A_{s_col} = 96.52\text{in}^2$$

$$A_{g_col} = (4.5\text{ft}) \cdot (15.5\text{ft}) \cdot \frac{144\text{in}^2}{1\text{ft}^2}$$

$$A_{g_col} = 10044\text{in}^2$$

$$\frac{A_{s_col}}{A_{g_col}} = 0.0096 \qquad 0.0096 \leq 0.08 \qquad \text{OK}$$

$$\frac{A_{s_col} \cdot f_y}{A_{g_col} \cdot f_c} = 0.144 \qquad 0.144 \geq 0.135 \qquad \text{OK}$$

The column slenderness ratio (Kl_u/r) about each axis of the column is computed below in order to assess slenderness effects. Note that the Specifications only permit the following approximate evaluation of slenderness effects when the slenderness ratio is below 100.

S5.7.4.3

S5.7.4.1

For this pier, the unbraced lengths (l_{ux}, l_{uy}) used in computing the slenderness ratio about each axis is the full pier height. This is the height from the top of the footing to the top of the pier cap (26 feet). The effective length factors, K_x and K_y , are both taken equal to 2.1. This assumes that the superstructure has no effect on restraining the pier from buckling. In essence, the pier is considered a free-standing cantilever.

CTable4.6.2.5-1

For simplicity in the calculations that follow, let $l_u = l_{ux} = l_{uy}$ and $K_{col} = K_x = K_y$. This is conservative for the transverse direction for this structure, and the designer may select a lower value. The radius of gyration (r) about each axis can then be computed as follows:

$$I_{xx} = \frac{1}{12} \cdot (186\text{in}) \cdot (54\text{in})^3 \quad I_{xx} = 2440692\text{in}^4$$

$$I_{yy} = \frac{1}{12} \cdot (54\text{in}) \cdot (186\text{in})^3 \quad I_{yy} = 28956852\text{in}^4$$

$$r_{xx} = \sqrt{\frac{I_{xx}}{A_{g_col}}}$$

$$r_{xx} = 15.59\text{in}$$

$$r_{yy} = \sqrt{\frac{I_{yy}}{A_{g_col}}}$$

$$r_{yy} = 53.69\text{in}$$

The slenderness ratio for each axis now follows:

$$K_{col} = 2.1$$

$$l_u = 312\text{in}$$

$$\frac{(K_{col} \cdot l_u)}{r_{xx}} = 42.03$$

$$42.03 < 100 \quad \text{OK}$$

$$\frac{(K_{col} \cdot l_u)}{r_{yy}} = 12.20$$

$$12.20 < 100 \quad \text{OK}$$

The Specifications permits slenderness effects to be ignored when the slenderness ratio is less than 22 for members not braced against sidesway. It is assumed in this example that the pier is not braced against sidesway in either its longitudinal or transverse directions. Therefore, slenderness will be considered for the pier longitudinal direction only (i.e., about the "X-X" axis).

S5.7.4.3

In computing the amplification factor that is applied to the longitudinal moment, which is the end result of the slenderness effect, the column stiffness (EI) about the "X-X" axis must be defined. In doing so, the ratio of the maximum factored moment due to permanent load to the maximum factored moment due to total load must be identified (β_d).

S4.5.3.2.2b

S5.7.4.3

From Design Step 8.7, it can be seen that the only force effects contributing to the longitudinal moment are the live load braking force and the temperature force. Neither of these are permanent or long-term loads. Therefore, β_d is taken equal to zero for this design.

The column stiffness is taken as the greater of the following two calculations:

$$E_c = 3640 \text{ ksi} \qquad I_{xx} = 2440692 \text{ in}^4$$

$$E_s = 29000 \text{ ksi} \qquad I_s = 44997 \text{ in}^4$$

$$EI_1 = \frac{(E_c \cdot I_{xx})}{5} + E_s \cdot I_s$$

$$EI_1 = 3.08 \times 10^9 \text{ K} \cdot \text{in}^2$$

$$EI_2 = \frac{E_c \cdot I_{xx}}{2.5}$$

$$EI_2 = 3.55 \times 10^9 \text{ K} \cdot \text{in}^2 \qquad (\text{controls})$$

The final parameter necessary for the calculation of the amplification factor is the phi-factor for compression. This value is defined as follows:

S5.5.4.2.1

$$\phi_{\text{axial}} = 0.75$$

It is worth noting at this point that when axial load is present in addition to flexure, the Specifications permit the value of phi to be increased linearly to the value for flexure (0.90) as the factored axial load decreases from ten percent of the gross concrete strength to zero. However, certain equations in the Specification still require the use of the phi factor for axial compression (0.75) even when the increase just described is permitted. Therefore, for the sake of clarity in this example, if phi may be increased it will be labeled separately from ϕ_{axial} identified above.

S5.5.4.2.1

$$A_{X_{col}} = 2435 \text{ K}$$

$$(0.10) \cdot (f_c) \cdot (A_{g_col}) = 4018 \text{ K}$$

Since the factored axial load in the column is less than ten percent of the gross concrete strength, the phi-factor will be modified and separately labeled as follows:

$$\phi_{Low_axial} = 0.90 - 0.15 \cdot \left[\frac{A_{X_{col}}}{((0.10)) \cdot (f_c) \cdot (A_{g_col})} \right]$$

$$\phi_{Low_axial} = 0.81$$

The longitudinal moment magnification factor will now be calculated as follows:

S4.5.3.2.2b

$$P_e = \frac{\pi^2 \cdot (EI_2)}{(K_{col} \cdot l_u)^2} \quad P_e = 81701 \text{ K}$$

$$\delta_s = \frac{1}{1 - \left(\frac{A_{X_{col}}}{\phi_{axial} \cdot P_e} \right)} \quad \delta_s = 1.04$$

The final design forces at the base of the column for the Strength I limit state will be redefined as follows:

$$P_{U_col} = A_{X_{col}} \quad P_{U_col} = 2435 \text{ K}$$

$$M_{Ux} = M_{ul_col} \cdot \delta_s \quad M_{Ux} = 2008 \text{ ft K}$$

$$M_{Uy} = M_{ut_col} \quad M_{Uy} = 9061 \text{ ft K}$$

The assessment of the resistance of a compression member with biaxial flexure for strength limit states is dependent upon the magnitude of the factored axial load. This value determines which of two equations provided by the Specification are used.

S5.7.4.5

If the factored axial load is less than ten percent of the gross concrete strength multiplied by the phi-factor for compression members (ϕ_{axial}), then the Specifications require that a linear interaction equation for only the moments is satisfied (*SEquation 5.7.4.5-3*). Otherwise, an axial load resistance (P_{rxy}) is computed based on the reciprocal load method (*SEquation 5.7.4.5-1*). In this method, axial resistances of the column are computed (using ϕ_{Low_axial} if applicable) with each moment acting separately (i.e., P_{rx} with M_{ux} , P_{ry} with M_{uy}). These are used along with the theoretical maximum possible axial resistance (P_o multiplied by ϕ_{axial}) to obtain the factored axial resistance of the biaxially loaded column.

Regardless of which of the two equations mentioned in the above paragraph controls, commercially available software is generally used to obtain the moment and axial load resistances.

For this pier design, the procedure as discussed above is carried out as follows:

$$(0.10) \cdot (\phi_{axial}) \cdot (f'_c) \cdot (A_{g_col}) = 3013 \text{ K}$$

$$P_{u_col} < 3013 \text{ K}$$

Therefore, *SEquation 5.7.4.5-3* will be used.

$$M_{ux} = 2008 \text{ ft}\cdot\text{K}$$

$$M_{uy} = 9061 \text{ ft}\cdot\text{K}$$

$$M_{rx} = 10440 \text{ ft}\cdot\text{K}$$

$$M_{ry} = 36113 \text{ ft}\cdot\text{K}$$

$$\frac{M_{ux}}{M_{rx}} + \frac{M_{uy}}{M_{ry}} = 0.44$$

$$0.44 \leq 1.0 \quad \text{OK}$$

The factored flexural resistances shown above, M_{rx} and M_{ry} , were obtained by the use of commercial software. These values are the flexural capacities about each respective axis assuming that no axial load is present. Consistent with this, the phi-factor for flexure (0.90) was used in obtaining the factored resistance from the factored nominal strength.

Although the column has a fairly large excess flexural capacity, a more optimal design will not be pursued per the discussion following the column shear check.

Design for Shear (Strength III and Strength V)

S5.8

The maximum factored transverse and longitudinal shear forces were derived in Design Step 8.7 and are as follows:

$$V_{ut_{col}} = 92.28 K \quad (\text{Strength III})$$

$$V_{ul_{col}} = 109.09 K \quad (\text{Strength V})$$

These maximum shear forces do not act concurrently. Although a factored longitudinal shear force is present in Strength III and a factored transverse shear force is present in Strength V, they both are small relative to their concurrent factored shear. Therefore, separate shear designs can be carried out for the longitudinal and transverse directions using only the maximum shear force in that direction.

For the pier column of this example, the maximum factored shear in either direction is less than one-half of the factored resistance of the concrete. Therefore, shear reinforcement is not required. This is demonstrated for the transverse direction as follows:

S5.8.2.4

$$b_v = 54 \text{ in} \quad h = 186 \text{ in}$$

S5.8.3.3

$$d_v = (0.72) \cdot (h)$$

S5.8.2.9

$$d_v = 133.92 \text{ in}$$

The above calculation for d_v is simple to use for columns and generally results in a conservative estimate of the shear capacity.

$$\beta = 2.0 \quad \theta = 45 \text{ deg}$$

S5.8.3.4.1

The nominal concrete shear strength is:

$$\sqrt{4}(1 \text{ ksi}) = 2.00 \text{ ksi}$$

$$V_c = 0.0316 \cdot \beta \cdot (2 \text{ ksi}) \cdot b_v \cdot d_v$$

S5.8.3.3

$$V_c = 914.08 K$$

The nominal shear strength of the column is the lesser of the following two values:

$$V_{n1} = V_c \qquad V_{n1} = 914.08 \text{ K} \qquad (\text{controls})$$

$$V_{n2} = 0.25 \cdot f_c \cdot b_v \cdot d_v \qquad V_{n2} = 7232 \text{ K}$$

S5.8.3.3

Define V_n as follows:

$$V_n = 914.08 \text{ K}$$

The factored shear resistance is:

$$\phi_v = 0.90$$

S5.5.4.2.1

$$V_r = \phi_v \cdot V_n$$

S5.8.2.1

$$V_r = 822.67 \text{ K}$$

$$\frac{V_r}{2} = 411.34 \text{ K}$$

$$\frac{V_r}{2} > V_{ut_{col}} \qquad \text{OK}$$

It has just been demonstrated that transverse steel is not required to resist the applied factored shear forces. However, transverse confinement steel in the form of hoops, ties or spirals is required for compression members. In general, the transverse steel requirements for shear and confinement must both be satisfied per the Specifications.

S5.7.4.6

S5.10.6

It is worth noting that although the preceding design checks for shear and flexure show the column to be oversized, a more optimal column size will not be pursued. The reason for this is twofold: First, in this design example, the requirements of the pier cap dictate the column dimensions (a reduction in the column width will increase the moment in the pier cap, while good engineering practice generally prescribes a column thickness 6 to 12 inches less than that of the pier cap). Secondly, a short, squat column such as the column in this design example generally has a relatively large excess capacity even when only minimally reinforced.

Transfer of Force at Base of Column

S5.13.3.8

The provisions for the transfer of forces and moments from the column to the footing are new to the AASHTO LRFD Specifications. Although similar provisions have existed in the ACI Building Code for some time, these provisions are absent from the AASHTO Standard Specifications. In general, standard engineering practice for bridge piers automatically satisfies most, if not all, of these requirements.

In this design example, and consistent with standard engineering practice, all steel reinforcing bars in the column extend into, and are developed, in the footing (see Figure 8-13). This automatically satisfies the following requirements for reinforcement across the interface of the column and footing: A minimum reinforcement area of 0.5 percent of the gross area of the supported member, a minimum of four bars, and any tensile force must be resisted by the reinforcement. Additionally, with all of the column reinforcement extended into the footing, along with the fact that the column and footing have the same compressive strength, a bearing check at the base of the column and the top of the footing is not applicable.

In addition to the above, the Specifications requires that the transfer of lateral forces from the pier to the footing be in accordance with the shear-transfer provisions of S5.8.4. With the standard detailing practices for bridge piers previously mentioned (i.e., all column reinforcement extended and developed in the footing), along with identical design compressive strengths for the column and footing, this requirement is generally satisfied. However, for the sake of completeness, this check will be carried out as follows:

$$A_{cv} = A_{g_col} \qquad A_{cv} = 10044 \text{ in}^2 \qquad \text{S5.8.4.1}$$

$$A_{vf} = A_{s_col} \qquad A_{vf} = 96.52 \text{ in}^2$$

$$c_{cv} = 0.100 \text{ ksi} \qquad \lambda = 1.00 \qquad \text{S5.8.4.2}$$

$$\mu = 1.0 \cdot \lambda \qquad \mu = 1.00$$

$$f_y = 60 \text{ ksi} \qquad f_c = 4.0 \text{ ksi}$$

$$\phi_v = 0.90 \qquad \text{S5.5.4.2.1}$$

The nominal shear-friction capacity is the smallest of the following three equations (conservatively ignore permanent axial compression):

S5.8.4.1

$$V_{nsf1} = c_{cv} \cdot A_{cv} + \mu \cdot A_{vf} \cdot f_y \quad V_{nsf1} = 6796 \text{ K}$$

$$V_{nsf2} = 0.2 \cdot f'_c \cdot A_{cv} \quad V_{nsf2} = 8035 \text{ K}$$

$$V_{nsf3} = 0.8 \cdot A_{cv} \cdot (1 \cdot \text{ksi}) \quad V_{nsf3} = 8035 \text{ K}$$

Define the nominal shear-friction capacity as follows:

$$V_{nsf} = V_{nsf1} \quad V_{nsf} = 6796 \text{ K}$$

The maximum applied shear was previously identified from the Strength V limit state:

$$V_{ulcol} = 109.09 \text{ K}$$

It then follows:

$$\phi_v \cdot (V_{nsf}) = 6116 \text{ K}$$

$$\phi_v \cdot (V_{nsf}) \geq V_{ulcol} \quad \text{OK}$$

As can be seen, a large excess capacity exists for this check. This is partially due to the fact that the column itself is overdesigned in general (this was discussed previously). However, the horizontal forces generally encountered with common bridges are typically small relative to the shear-friction capacity of the column (assuming all reinforcing bars are extended into the footing). In addition, the presence of a shear-key, along with the permanent axial compression from the bridge dead load, further increase the shear-friction capacity at the column/footing interface beyond that shown above. This may account for the absence of this check in both the Standard Specifications and in standard practice.



Transfer of Force at Column Base

For common bridges with standard detailing of bridge piers and the same design compressive strength of the column and the footing, S5.13.3.8 can be considered satisfied.

Design Step 8.10 - Design Pier Piles

The foundation system for the pier is a reinforced concrete footing on steel H-piles. The force effects in the piles cannot be determined without a pile layout. The pile layout depends upon the pile capacity and affects the footing design. The pile layout used for this pier foundation is shown in Figure 8-11.

S10.7

Based on the given pile layout, the controlling limit states for the pile design were given in Design Step 8.7. However, pile loads were not provided. The reason for this is that the pile design will not be performed in this design step. The abutment foundation system, discussed in Design Step 7, is identical to that of the pier, and the pile design procedure is carried out in its entirety there. Although individual pile loads may vary between the abutment and the pier, the design procedure is similar. The pile layout shown in Figure 8-11 is used only to demonstrate the aspects of the footing design that are unique to the pier. This is discussed in the next design step.

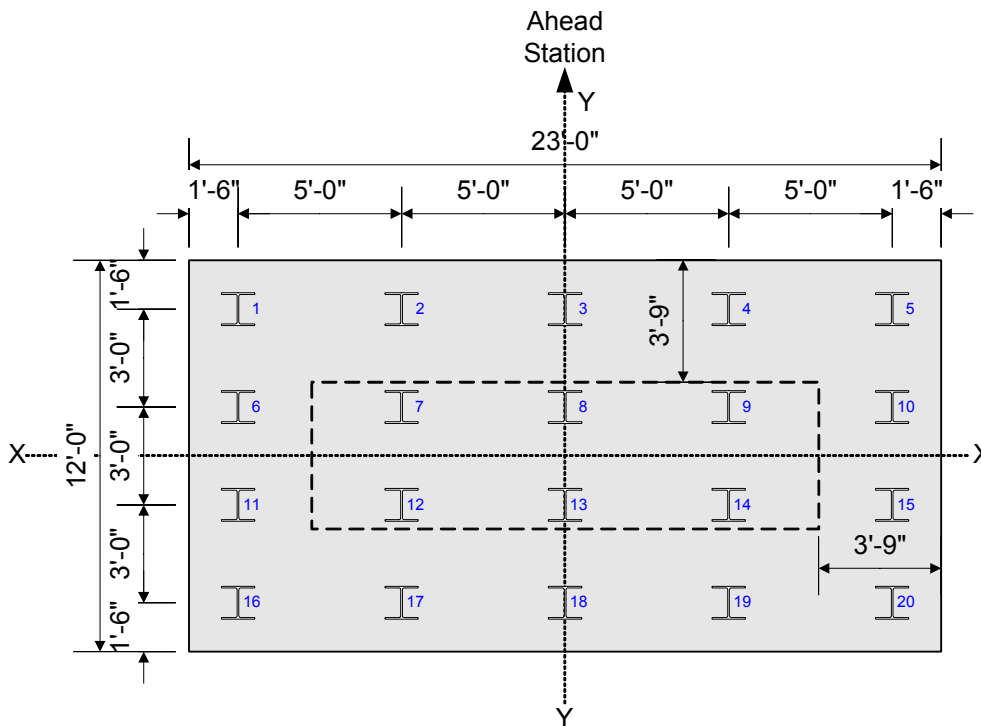

Figure 8-11 Pier Pile Layout

Design Step 8.11 - Design Pier Footing

In Design Step 8.7, the governing limit states were identified for the design of the pier footing. However, the factored force effects were only given for the Strength I check of punching shear at the column. The reason for this is that most of the design checks for the pier footing are performed similarly to those of the abutment footing in Design Step 7. Therefore, only the aspects of the footing design that are unique to the pier footing will be discussed in this design step. This includes the punching (or two-way) shear check at the column and a brief discussion regarding estimating the applied factored shear and moment per foot width of the footing when adjacent pile loads differ.

The factored force effects from Design Step 8.7 for the punching shear check at the column are:

$$A_{x_{col_punch}} = 3583K$$

$$M_{ut_{col_punch}} = 5287ft \cdot K$$

$$M_{ul_{col_punch}} = 2756ft \cdot K$$

It should be noted that in Design Step 8.5, the live load reactions at the bearings include dynamic load allowance on the truck loads. These live load force effects are part of the factored axial load and transverse moment shown above. However, the Specifications do not require dynamic load allowance for foundation components that are entirely below ground level. Therefore, the resulting pile loads will be somewhat larger (by about four percent) than necessary for the following design check. For the sake of clarity and simplicity in Design Step 8.5, a separate set of live load reactions with dynamic load allowance excluded was not provided.

The longitudinal moment given above must be magnified to account for slenderness of the column (see Design Step 8.9). The computed magnification factor and final factored forces are:

$$\delta_{s_punch} = 1.06$$

$$P_{u_punch} = A_{x_{col_punch}} \qquad P_{u_punch} = 3583K$$

$$M_{ux_punch} = (M_{ul_{col_punch}}) \cdot (\delta_{s_punch})$$

$$M_{ux_punch} = 2921 ftK$$

S3.6.2.1

$$M_{uy_punch} = M_{utcol_punch}$$

$$M_{uy_punch} = 5287 \text{ ftK}$$

With the applied factored loads determined, the next step in the column punching shear check is to define the critical perimeter, b_o . The Specifications require that this perimeter be minimized, but need not be closer than $d_v/2$ to the perimeter of the concentrated load area. In this case, the concentrated load area is the area of the column on the footing as seen in plan.

S5.13.3.6.1

The effective shear depth, d_v , must be defined in order to determine b_o and the punching (or two-way) shear resistance. Actually, an average effective shear depth should be used since the two-way shear area includes both the "X-X" and "Y-Y" sides of the footing. In other words, d_{ex} is not equal to d_{ey} , therefore d_{vx} will not be equal to d_{vy} . This is illustrated as follows assuming a 3'-6" footing with #9 reinforcing bars at 6" on center in both directions in the bottom of the footing:

S5.13.3.6.3

$$\text{bar_area9} = 1.00 \text{ in}^2$$

$$\text{bar_diam9} = 1.128 \text{ in}$$

$$b_{ftg} = 12 \text{ in}$$

$$h_{ftg} = 42 \text{ in}$$

$$A_{s_ftg} = 2 \cdot (\text{bar_area9})$$

$$A_{s_ftg} = 2.00 \text{ in}^2 \quad (\text{per foot width})$$

Effective depth for each axis:

$$\text{Cover}_{ftg} = 3 \text{ in}$$

$$d_{ey} = 42 \text{ in} - \text{Cover}_{ftg} - \frac{\text{bar_diam9}}{2}$$

$$d_{ey} = 38.44 \text{ in}$$

$$d_{ex} = 42 \text{ in} - \text{Cover}_{ftg} - \text{bar_diam9} - \frac{\text{bar_diam9}}{2}$$

$$d_{ex} = 37.31 \text{ in}$$

Effective shear depth for each axis:

$$T_{ftg} = A_{s_ftg} \cdot f_y$$

$$T_{ftg} = 120.00 \text{ K}$$

$$a_{ftg} = \frac{T_{ftg}}{0.85 \cdot f_c \cdot b_{ftg}}$$

$$a_{ftg} = 2.94 \text{ in}$$

$$d_{vx} = \max\left(d_{ex} - \frac{a_{ftg}}{2}, 0.9 \cdot d_{ex}, 0.72 \cdot h_{ftg}\right)$$

S5.8.2.9

$$d_{vx} = 35.84 \text{ in}$$

$$d_{vy} = \max\left(d_{ey} - \frac{a_{ftg}}{2}, 0.9 \cdot d_{ey}, 0.72 \cdot h_{ftg}\right)$$

S5.8.2.9

$$d_{vy} = 36.97 \text{ in}$$

Average effective shear depth:

$$d_{v_avg} = \frac{(d_{vx} + d_{vy})}{2}$$

$$d_{v_avg} = 36.40 \text{ in}$$

With the average effective shear depth determined, the critical perimeter can be calculated as follows:

$$b_{col} = 186 \text{ in}$$

$$t_{col} = 54 \text{ in}$$

$$b_0 = 2 \left[b_{\text{col}} + 2 \cdot \left(\frac{d_{v_avg}}{2} \right) \right] + 2 \cdot \left[t_{\text{col}} + 2 \cdot \left(\frac{d_{v_avg}}{2} \right) \right]$$

$$b_0 = 625.61 \text{ in}$$

The factored shear resistance to punching shear is the smaller of the following two computed values:

$$\beta_c = \frac{b_{\text{col}}}{t_{\text{col}}} \qquad \beta_c = 3.44$$

$$\sqrt{4}(1 \cdot \text{ksi}) = 2.00 \text{ ksi}$$

$$V_{n_punch1} = \left(0.063 + \frac{0.126}{\beta_c} \right) \cdot 2 \text{ ksi} \cdot (b_0) \cdot (d_{v_avg})$$

$$V_{n_punch1} = 4535 \text{ K}$$

$$V_{n_punch2} = 0.126 \cdot (2 \text{ ksi}) \cdot (b_0) \cdot (d_{v_avg})$$

$$V_{n_punch2} = 5739 \text{ K}$$

Define V_{n_punch} as follows:

$$V_{n_punch} = V_{n_punch1}$$

$$\phi_v = 0.90$$

$$V_{r_punch} = \phi_v \cdot (V_{n_punch})$$

$$V_{r_punch} = 4082 \text{ K}$$

With the factored shear resistance determined, the applied factored punching shear load will be computed. This value is obtained by summing the loads in the piles that are outside of the critical perimeter. As can be seen in Figure 8-12, this includes Piles 1 through 5, 6, 10, 11, 15, and 16 through 20. These piles are entirely outside of the critical perimeter. If part of a pile is inside the critical perimeter, then only the portion of the pile load outside the critical perimeter is used for the punching shear check.

S5.13.3.6.3

S5.13.3.6.1

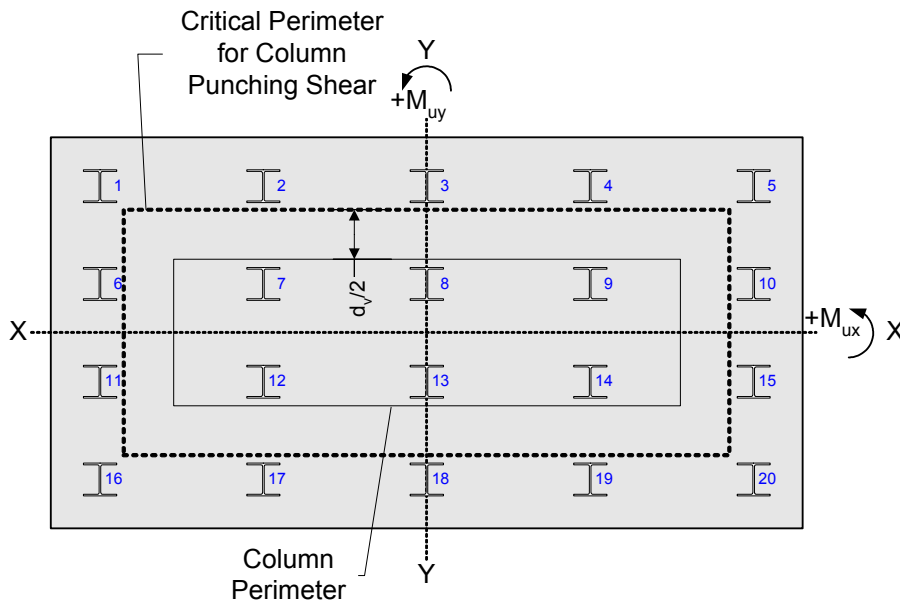

Figure 8-12 Critical Perimeter for Column Punching Shear

The following properties of the pile group are needed to determine the pile loads (reference Figures 8-11 and 8-12):

$$n_{\text{piles}} = 20$$

$$I_{p_xx} = 5 \cdot [(1.5\text{ft})^2 + (4.5\text{ft})^2] \cdot 2$$

$$I_{p_xx} = 225 \text{ft}^2$$

$$I_{p_yy} = 4 \cdot [(5\text{ft})^2 + (10\text{ft})^2] \cdot 2$$

$$I_{p_yy} = 1000 \text{ft}^2$$

The following illustrates the pile load in Pile 1:

$$P_1 = \frac{P_{u_punch}}{n_{\text{piles}}} + \frac{M_{ux_punch} \cdot (4.5\text{ft})}{I_{p_xx}} + \frac{M_{uy_punch} \cdot (10\text{ft})}{I_{p_yy}}$$

$$P_1 = 290.45 \text{K}$$

Similar calculations for the other piles outside of the critical perimeter yield the following:

$$P_2 = 263.47K$$

$$P_3 = 237.03K$$

$$P_4 = 210.6K$$

$$P_5 = 184.16K$$

$$P_6 = 251.31K$$

$$P_{10} = 145.57K$$

$$P_{11} = 212.73K$$

$$P_{15} = 106.99K$$

$$P_{16} = 174.14K$$

$$P_{17} = 147.71K$$

$$P_{18} = 121.27K$$

$$P_{19} = 94.84K$$

$$P_{20} = 68.40K$$

The total applied factored shear used for the punching shear check is:

$$V_{u_punch} = P_1 + P_2 + P_3 + P_4 + P_5 + P_6 + P_{10} \dots \\ + P_{11} + P_{15} + P_{16} + P_{17} + P_{18} + P_{19} + P_{20}$$

$$V_{u_punch} = 2509K$$

$$V_{u_punch} \leq V_{r_punch} \quad \text{OK}$$



Alternate Punching Shear Load Calculation

An alternate method for carrying out the column punching shear check is to simply use the applied factored axial load to obtain equal pile loads in all of the piles. This is only valid for the case where the piles outside of the critical perimeter are symmetric about both axes. The applied factored shear on the critical section is obtained as above (i.e., the sum of the piles located outside of the critical perimeter). This approach yields the same value for V_{u_punch} as was derived above. This is illustrated as follows:

$$V_{u_punch_alt} = \left(\frac{P_{u_punch}}{n_{piles}} \right) \cdot 14$$

$$V_{u_punch_alt} = 2508 \text{ K}$$

$$V_{u_punch_alt} = V_{u_punch}$$

It has just been shown that the factored axial load alone is sufficient for the punching shear check at the column. However, consideration of the factored axial load along with the corresponding applied factored moments is necessary for other footing design checks such as punching shear at the maximum loaded pile, one-way shear, and flexure. This applies to the abutment footing in Design Step 7 as well. However, what is unique to the pier footing is that significant moments act about both axes. What follows is a demonstration, using the pile forces previously computed, of an estimation of the applied factored load on a per-foot basis acting on each footing face. The following estimations are based on the outer row of piles in each direction, respectively. Once these estimates are obtained, the appropriate footing design checks are the same as those for the abutment footing.

$$L_{ftg_xx} = 23\text{ft}$$

$$L_{ftg_yy} = 12\text{ft}$$

Estimation of applied factored load per foot in the "X" direction:

$$R_{estimate_xx} = \frac{2 \cdot (P_1 + P_2) + P_3}{L_{ftg_xx}}$$

$$R_{estimate_xx} = 58.47 \frac{\text{K}}{\text{ft}}$$

Estimation of applied factored load per foot in the "Y" direction:

$$R_{estimate_yy} = \frac{2 \cdot (P_1 + P_6)}{L_{ftg_yy}}$$

$$R_{estimate_yy} = 90.29 \frac{\text{K}}{\text{ft}}$$

Design Step 8.12 - Final Pier Schematic

Figure 8-13 shows the final pier dimensions along with the required reinforcement in the pier cap and column.

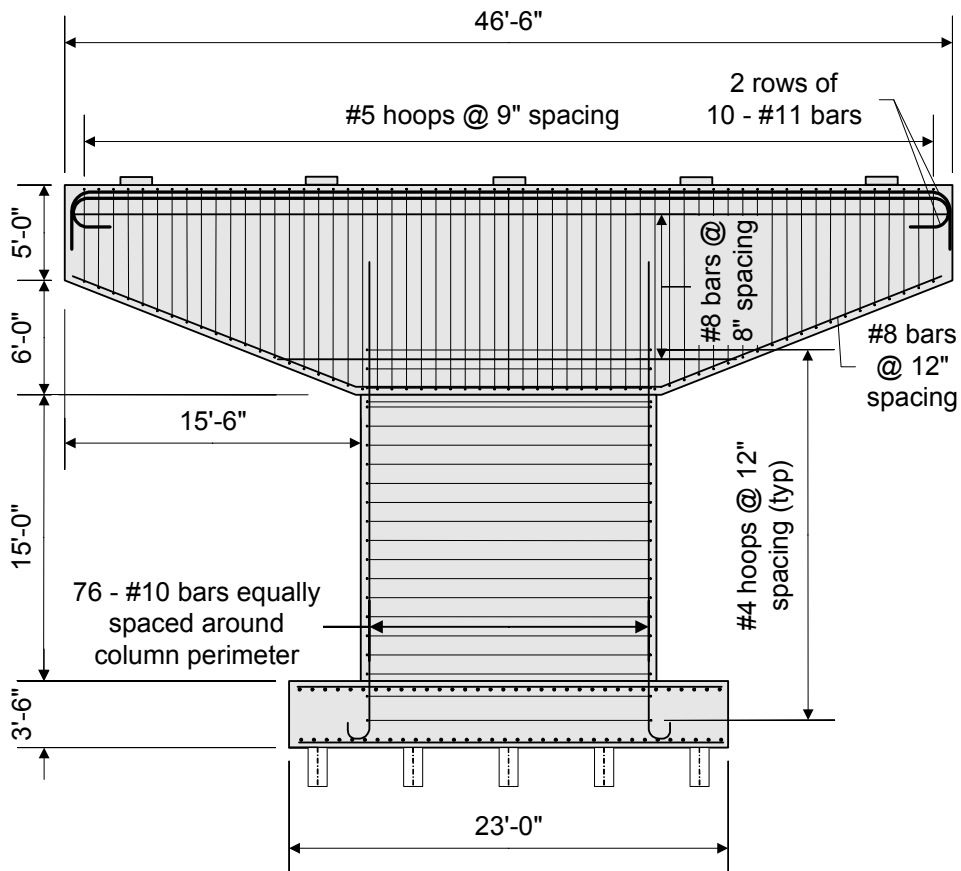

Figure 8-13 Final Pier Design

Pile Foundation Design Example Design Step P

<u>Table of Contents</u>	<u>Page</u>
Design Step P.1 - Define Subsurface Conditions and Any Geometric Constraints	2
Design Step P.2 - Determine Applicable Loads and Load Combinations	13
Design Step P.3 - Factor Loads for Each Combination	14
Design Step P.4 - Verify Need for a Pile Foundation	16
Design Step P.5 - Select Suitable Pile Type and Size	23
Design Step P.6 - Determine Nominal Axial Structural Resistance for Selected Pile Type / Size	32
Design Step P.7 - Determine Nominal Axial Geotechnical Resistance for Selected Pile Type / Size	33
Design Step P.8 - Determine Factored Axial Structural Resistance for Single Pile	36
Design Step P.9 - Determine Factored Axial Geotechnical Resistance for Single Pile	37
Design Step P.10 - Check Drivability of Pile	38
Design Step P.11 - Do Preliminary Pile Layout Based on Factored Loads and Overturning Moments	53
Design Step P.12 - Evaluate Pile Head Fixity	63
Design Step P.13 - Perform Pile Soil Interaction Analysis	65
Design Step P.14 - Check Geotechnical Axial Capacity	77
Design Step P.15 - Check Structural Axial Capacity (in lower portion of pile)	78
Design Step P.16 - Check Structural Axial Capacity in Combined Bending and Axial Load (upper portion of pile)	79
Design Step P.17 - Check Structural Shear Capacity	89

Design Step P.18 - Check Maximum Horizontal and Vertical Deflection of Pile Group at Beam Seats Using Service Load Case	91
Design Step P.19 - Additional Miscellaneous Design Issues	92
References	103

Design Step P.1 - Define Subsurface Conditions and Any Geometric Constraints

This task involves determining the location and extent of soil and rock materials beneath the proposed abutment and determining engineering design properties for each of those materials. It also includes identification of any specific subsurface conditions that may impact the performance of the structure. The design of the foundation system needs to address any identified issues.

A subsurface investigation was conducted at the site. Two test borings were drilled at each substructure unit. Soils were sampled at 3 foot intervals using a split spoon sampler in accordance with ASTM D-1586. Rock was continuously sampled with an N series core barrel in accordance with ASTM D-2113.

For Abutment 1, one boring was drilled at each side of the abutment. These borings are illustrated graphically in Section A1 below.

Refer to Design Step 1 for introductory information about this design example. Additional information is presented about the design assumptions, methodology, and criteria for the entire bridge, including the Pile Foundation Design.

The following units are defined for use in this design example:

$$\begin{array}{cccc}
 \text{PCF} = \frac{\text{lb}}{\text{ft}^3} & \text{ksi} = \frac{1000 \cdot \text{lb}}{\text{in}^2} & \text{TSF} = \frac{\text{ton}}{\text{ft}^2} & \text{kilo} = 1000 \\
 \\
 \text{KSF} = \frac{1000 \cdot \text{lb}}{\text{ft}^2} & \text{K} = 1000 \cdot \text{lb} & \text{psi} = \frac{\text{lb}}{\text{in}^2} & \text{PSF} = \frac{\text{lb}}{\text{ft}^2}
 \end{array}$$

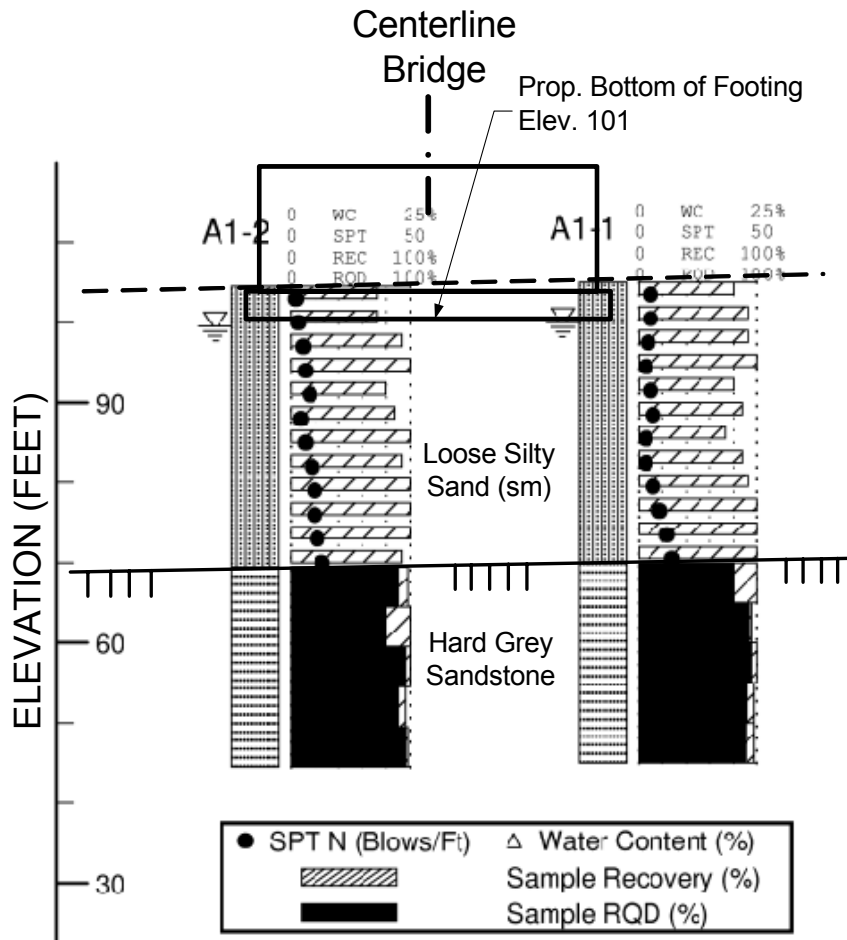

Figure P-1 Section A1 - Subsurface Conditions at Abutment 1

Evaluation of Section A1 indicates that subsurface conditions are relatively uniform beneath the proposed abutment consisting of essentially 2 materials.

Loose silty sand was encountered in the top 35 feet of each boring. This material is non-plastic and contains about 15% fine material. Below a depth of about 5' the soil is saturated.

Rock was encountered at about elevation 70 in both borings. The rock consists of a hard gray sandstone. Fractures are tight with no infilling and occur at a spacing of 1-3'; primarily along bedding planes which are horizontal. Slight weathering was observed in the upper 1' foot of the rock but the remainder of the rock is unweathered.

Special Geotechnical Considerations:

The loose fine sandy soils could be subject to liquefaction under seismic loading. Liquefaction is a function of the anticipated maximum earthquake magnitude and the soil properties. If liquefaction is a problem, the soils can not be relied upon to provide lateral support to deep foundation systems. For this example it is assumed that the potential for liquefaction has been evaluated and has been found to be negligible. (Note: Seed and Idriss (NCEER-97-0022) provides more up to date material for evaluation of liquefaction)

*C10.5.4,
SAppendix A10*

The weight of the approach embankment will cause compression of the loose soil horizon. The granular material should compress essentially elastically with little or no long term consolidation. However, since the full height abutment will likely be placed prior to completion of the approach embankment in the vicinity of the abutment, soil compression beneath the abutment must be accounted for in foundation design. For shallow foundations, this compression will result in settlement and rotation of the footing. For deep foundations this compression could result in negative skin friction (downdrag) loads on the foundation elements; particularly in the back row of piles.

*S10.7.1.4,
C10.7.1.4*

Development of Parameters for Design:**Layer 1 - Soil****Depth:**

Assuming a bottom of footing elevation of 101 FT and a top of rock elevation of 70 FT as described above:

$$101 \cdot \text{ft} - 70 \cdot \text{ft} = 31 \text{ ft}$$

Unit Weight (γ):

Consider relevant published data when selecting design parameters. For unit weights of in-situ soil materials, a good reference is NAVFAC DM7.1-22. Based on this reference, general and local experience, and the above description of the soil horizon as loose silty sand, the unit weights were selected as follows:

Dry unit weight: $\gamma_{\text{dry}} = 90 \cdot \text{PCF}$

Wet unit weight: $\gamma_{\text{wet}} = 110 \cdot \text{PCF}$

Unit weight of water: $\gamma_{\text{water}} = 62.4 \cdot \text{PCF}$

Effective unit weight: $\gamma_{\text{eff}} = \gamma_{\text{wet}} - \gamma_{\text{water}}$

$$\gamma_{\text{eff}} = 47.6 \text{ PCF}$$

C10.4.1

Angle of internal friction (ϕ):

The angle of internal friction can be estimated based on correlation to Standard Penetration Test (SPT) N values. The raw SPT N-values determined in the test borings must be corrected for overburden pressure as follows:

$$N_{\text{corr}} = \left(0.77 \cdot \log \left(\frac{20}{\sigma'_v} \right) \right) \cdot N$$

SEquation
10.7.2.3.3-4

where:

Corrected SPT blow count (Blows/FT) N_{corr}
 Note: The formula above is generally considered valid for values of $\sigma' > 0.25$ TSF (Bowles 1977):

SPT blow count (Blows/FT): N

Vertical effective stress at bottom of sample (TSF): σ'_v

$$\sigma'_v = \frac{\sum (h_i \cdot Y_{\text{effi}})}{2000}$$

where:

Thickness of soil layer i above point being considered (FT): h_i

Effective unit weight of soil layer i (PCF): Y_{effi}

Number of soil layer under consideration: i

This formula is implemented for each of the borings below. Wet unit weight is used for the soil above the water table and effective unit weight is used for the soil below the water table.

Depth to Top of Sample (FT)	Depth to Bottom of Sample (FT)	$\gamma_{eff\ i}$ (PCF)	σ_v' (TSF)	N Blows/Ft (BPF)	N_{corr} Blows/Ft (BPF)
Boring A1-1					
0	1.5	110	0.0825	5	9
3	4.5	110	0.2475	5	7
6	7.5	47.6	0.3189	4	6
9	10.5	47.6	0.3903	3	4
12	13.5	47.6	0.4617	5	6
15	16.5	47.6	0.5331	6	7
18	19.5	47.6	0.6045	3	4
21	22.5	47.6	0.6759	3	3
24	25.5	47.6	0.7473	6	7
27	28.5	47.6	0.8187	9	10
30	31.5	47.6	0.8901	12	12
33	34.5	47.6	0.9615	14	14
Boring A1-2					
0	1.5	110	0.0825	2	4
3	4.5	110	0.2475	3	4
6	7.5	47.6	0.3189	5	7
9	10.5	47.6	0.3903	6	8
12	13.5	47.6	0.4617	8	10
15	16.5	47.6	0.5331	4	5
18	19.5	47.6	0.6045	6	7
21	22.5	47.6	0.6759	9	10
24	25.5	47.6	0.7473	10	11
27	28.5	47.6	0.8187	10	11
30	31.5	47.6	0.8901	11	11
33	34.5	47.6	0.9615	13	13

Table P-1 Calculation of Corrected SPT Blow Count

Find average values for zone between bottom of footing and top of rock. This means ignoring the first two values of each boring.

$$N = 7.35 \text{ BPF}$$

$$N_{corr} = 8.3 \text{ BPF}$$

The correlation published in FHWA-HI-96-033 Page 4-17 (after Bowles, 1977) is used to determine the angle of internal friction. This correlation is reproduced below.

Description	Very Loose	Loose	Medium	Dense	Very Dense
$N_{\text{corr}} =$	0-4	4-10	10-30	30-50	>50
$\phi_f =$	25-30°	27-32°	30-35°	35-40°	38-43°
$a =$	0.5	0.5	0.25	0.15	0
$b =$	27.5	27.5	30	33	40.5

Table P-2 Correlation

This correlation can be expressed numerically as:

$$\phi'_f = a \cdot N_{\text{corr}} + b$$

where:

a and b are as listed in Table P-2.

$$a = 0.5$$

$$N_{\text{corr}} = 8.3$$

$$b = 27.5$$

Thus

$$\phi'_f = a \cdot N_{\text{corr}} + b$$

$$\phi'_f = 31.65^\circ \quad \text{say} \quad \phi'_f = 31^\circ$$

Modulus of elasticity (E):

Estimating E_0 from description

Loose Fine Sand $E_0 = 80 - 120$ TSF

Estimating E_0 from N_{corr}

Note, in Table 10.6.2.2.3b-1 N_1 is equivalent to N_{corr}

Clean fine to medium sands and slightly silty sands

$$E_0 = 7 \cdot N_1$$

$$E_0 = 7 \cdot N_{\text{corr}}$$

$$E_0 = 58.1 \text{ TSF}$$

Based on above, use:

$$E_0 = 60 \cdot \text{TSF}$$

$$E_0 = 0.833 \text{ ksi}$$

Poisons Ratio (ν):

Estimating ν from description

Loose Fine Sand: $\nu = 0.25$

Shear Modulus (G):

From Elastic Theory:

$$G_0 = \frac{E_0}{2 \cdot (1 + \nu)}$$

$$G_0 = 24 \text{ TSF}$$

$$G_0 = 0.33 \text{ ksi}$$

STable
10.6.2.2.3b-1

STable
10.6.2.2.3b-1

STable
10.6.2.2.3b-1

Coefficient of variation of subgrade reaction (k):

As per FHWA-HI-96-033, Table 9-13:

This is used for lateral analysis of deep foundation elements

Submerged Loose Sand

$$k = 5430 \cdot \frac{\text{kilo} \cdot \text{newton}}{\text{m}^3} \quad k = 20 \cdot \text{psi}$$

Layer 2 - Rock:**Depth:**

Rock is encountered at elevation 70 and extends a minimum of 25 FT beyond this point.

Unit Weight (Y):

Determined from unconfined compression tests on samples of intact rock core as listed below:

Boring No.	Depth (FT)	Y (PCF)
A1-1	72.5	152
A1-1	75.1	154
A1-2	71.9	145
A1-2	76.3	153
P1-1	81.2	161
P1-2	71.8	142
A2-1	76.3	145
A2-2	73.7	151
Average Y		150.375

Table P-3 Unit Weight

$$Y_{ave} = 150.375 \cdot \text{PCF}$$

Unconfined Compressive Strength (q):

Determined from unconfined compression tests on samples of intact rock core as listed below:

Boring No.	Depth (FT)	q _u (PSI)
A1-1	72.5	12930
A1-1	75.1	10450
A1-2	71.9	6450
A1-2	76.3	12980
P1-1	81.2	14060
P1-2	71.8	6700
A2-1	76.3	13420
A2-2	73.7	14890
Average q _u		11485

Table P-4 Unconfined Compressive Strength

$$q_{uave} = 11485 \cdot \text{psi}$$

Modulus of elasticity (E):

This is to be used for prediction of deep foundation response

For sandstone, Average: $E_0 = 153000 \cdot \text{TSF}$

$$E_0 = 2125 \text{ ksi}$$

Poisons Ratio (ν):

This is to be used for prediction of pile tip response

For sandstone, Average: $\nu_{ave} = 0.2$

STable
10.6.2.2.3d-2

STable
10.6.2.2.3d-1

Shear Modulus (G):

From elastic theory

$$G_0 = \frac{E_0}{2 \cdot (1 + \nu_{ave})}$$

$$G_0 = 63750 \text{ TSF}$$

$$G_0 = 885.417 \text{ ksi}$$

Rock Mass Quality:

Rock mass quality is used to correct the intact rock strength and intact modulus values for the effects of existing discontinuities in the rock mass. This is done through empirical correlations using parameters determined during core drilling.

Data from the test borings is summarized below:

Depth (FT)	Run Length (FT)	Recovery (%)	RQD (%)
Boring A1-1			
35	5	100	80
40	5	96	94
45	5	100	96
50	5	98	92
55	5	98	90
Boring A1-2			
35	5	98	90
40	5	100	80
45	5	100	96
50	5	96	90
55	5	98	96
Averages		98.4	90.4

Table P-5 Rock Mass Quality

Design Step P.2 - Determine Applicable Loads and Load Combinations

Loads and load combinations are determined elsewhere in the design process. The critical load cases for evaluation of foundation design are summarized below:

- 1). The load combination that produces the maximum vertical load on the foundation system. This will typically be a Strength I and a Service I load case with the maximum load factors applied.
- 2). The load combination that produces the maximum overturning on the foundation which will tend to lift a spread footing off the bearing stratum or place deep foundation elements in tension.
- 3). The load combination that produces the maximum lateral load. If several combinations produce the same horizontal load, select the one with the minimum vertical load as this will be critical for evaluation of spread footing sliding or response of battered deep foundations. In some cases, particularly deep foundations employing all vertical elements, the highest lateral load and associated highest vertical load should also be evaluated as this case may produce higher foundation element stress and deflections due to combined axial load and bending in the foundation elements.

Design Step P.3 - Factor Loads for Each Combination

It is extremely important to understand where the loads are being applied with respect to foundation design. In this case the loads were developed based on an assumed 10' 3" wide by 46' 10 1/2" long footing that is offset behind the bearings a distance of 1' 9". The loads are provided at the horizontal centroid of the assumed footing and at the bottom of that footing. A diagram showing the location and direction of the applied loads is provided below.

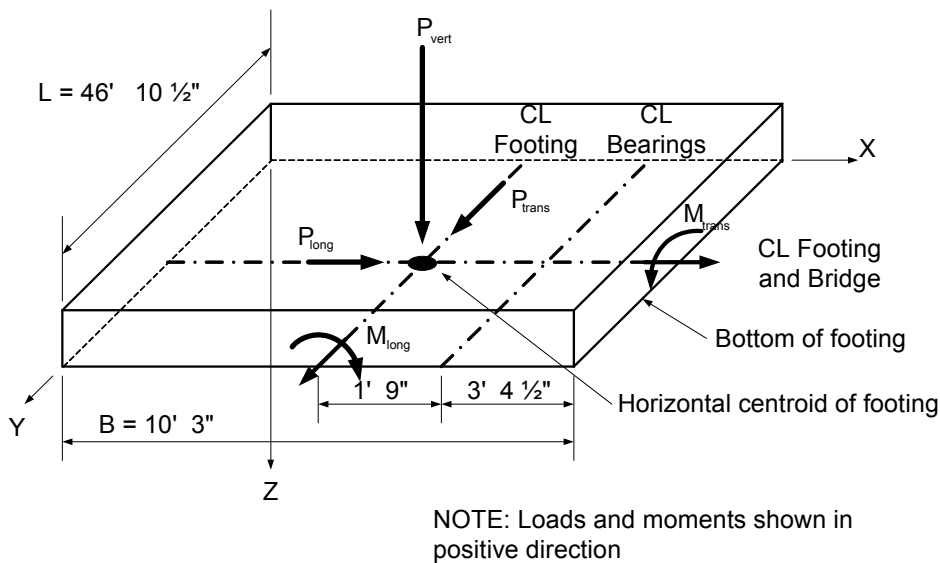

Figure P-2 Application of Loads

	LIMIT STATE	AXIAL FORCE P_{vert} (K)	LONG MOMENT M_{long} (K-FT)	TRANS MOMENT M_{trans} (K-FT)	LATERAL LOAD (IN LONG. DIR.) P_{long} (K)	LATERAL LOAD (IN TRANS. DIR.) P_{trans} (K)
Maximum Vertical Load	STR-I MAX/FIN	2253	7693	0	855	0
	SER-I MAX/FIN	1791	4774	162	571	10
Maximum Overturning	STR-I MIN/FIN	1860	7291	0	855	0
	SER-I MIN/FIN	1791	4709	162	568	10
Maximum Lateral Load	STR-III MAX/FIN	1815	6374	508	787	37
	SER-I MAX/FIN	1791	4774	162	571	10

Table P-6 Summary of Factored Loads

It should be noted that the calculations performed in Design Step P are based on preliminary pile foundation design forces. In an actual design, the geotechnical engineer would need to revisit the pile foundation design calculations and update the results based on the final design bottom of footing forces given at the end of Design Step 7.7.

Design Step P.4 - Verify Need for a Pile Foundation

Evaluate a spread footing design:

Check vertical capacity:

Presumptive Bearing Capacity for loose sand with silt (SM)

Presumptive bearing capacity $SM = 1.5 \cdot TSF$

$$SM = 3 \text{ KSF}$$

Presumptive bearing capacity is a service limit state, thus compare against maximum service load.

From Design Step P.3,
the Maximum service load is $P_{\text{vert}} = 1791 \cdot K$

The Required area: $A = 597 \cdot \text{ft}^2$

The length of the footing is controlled by the length of the abutment step required to support the steel beams and the approach roadway. This is determined from previous geometry calculations.

Maximum possible length of footing $L = 46.875 \cdot \text{ft}$

Preliminary minimum required width $B_{\text{min}} = 12.736 \cdot \text{ft}$

STable
10.6.2.3.1-1

S10.5.2

Excessive loss of contact:

This is a strength limit state thus use strength loads for the case of maximum overturning which is STR I Min.

S10.5.3

Determine the maximum eccentricity e_B in the direction parallel to the width of the footing (B)

$$e_B = \frac{M_{\text{long}}}{P_{\text{vert}}}$$

From the loads obtained in Design Step P.3, $M_{\text{long}} = 7291 \cdot \text{K} \cdot \text{ft}$

$$P_{\text{vert}} = 1860 \cdot \text{K}$$

$$e_B = \frac{M_{\text{long}}}{P_{\text{vert}}}$$

$$e_B = 3.92 \text{ ft}$$

To prevent excessive loss of contact e_B must be less than $B/4$.

S10.6.3.1.5

Width of the footing: $B_i = 10.25 \cdot \text{ft}$

$$\frac{B_i}{4} = 2.563 \text{ ft}$$

In order to resolve the bearing pressure and eccentricity issue, the footing will have to be widened and the centroid shifted toward the toe. This can be accomplished by adding width to the toe of the footing. Note that the issue could also be resolved by adding width to the heel of the footing, which would increase the weight of soil that resists overturning. This would require recalculation of the loads and was not pursued here.

In order to satisfy bearing pressure and eccentricity concerns, the footing width is increased incrementally until the following two criteria are met:

$$e_B < \frac{B_i}{4} \quad \text{Based on Strength Loads}$$

$$B' > B_{\min} = 12.736 \text{ ft} \quad \text{Based on Service Loads}$$

Where B' is the effective footing width under eccentric load

$$B' = B_i - 2 \cdot e_B$$

SEquation
10.6.3.1.5-1

For the Strength Load case:

Footing width B (FT)	Distance from heel to Centroid of footing (FT)	Distance from heel to centroid of load (FT)	e_B (FT)	$B/4$ (FT)
10.25	5.13	9.05	3.92	2.56
11.00	5.50	9.05	3.55	2.75
12.00	6.00	9.05	3.05	3.00
13.00	6.50	9.05	2.55	3.25
14.00	7.00	9.05	2.05	3.50
15.00	7.50	9.05	1.55	3.75
16.00	8.00	9.05	1.05	4.00
17.00	8.50	9.05	0.55	4.25

Table P-7 Excessive Loss of Contact - Strength

For the Strength Load Case, the condition was satisfied first when the width of the footing $B = 13.00$ FT

For the Service Load Case

$$e_B = \frac{M_{\text{long}}}{P_{\text{vert}}}$$

From the loads obtained from Design Step P.3, $M_{\text{long}} = 4774 \cdot \text{K} \cdot \text{ft}$

$$P_{\text{vert}} = 1791 \cdot \text{K}$$

$$e_B = \frac{M_{\text{long}}}{P_{\text{vert}}}$$

$$e_B = 2.67 \text{ ft}$$

Footing width B (FT)	Distance from heel to Centroid of footing (FT)	Distance from heel to centroid of load (FT)	e_B (FT)	B' (FT)
10.25	5.13	7.80	2.67	4.91
11.00	5.50	7.80	2.30	6.41
12.00	6.00	7.80	1.80	8.41
13.00	6.50	7.80	1.30	10.41
14.00	7.00	7.80	0.80	12.41
15.00	7.50	7.80	0.30	14.41
16.00	8.00	7.80	-0.21	16.41

Table P-8 Presumptive Bearing Pressure - Service

For the Service Load Case, the condition was satisfied first when the width of the footing B = 15.00 FT

The first width to satisfy both conditions is 15.00 FT.
Which would require the toe of the footing to be extended:

$$\Delta B = 15 \cdot \text{ft} - B_i$$

$$\Delta B = 4.75 \text{ ft}$$

This increase may not be possible because it may interfere with roadway drainage, roadside utilities, or the shoulder pavement structure. However, assume this is not the case and investigate potential settlement of such a footing.

Settlement is a service limit state check.

For the granular subsoils, settlement should be essentially elastic thus Settlement (S_0) is computed from:

$$S_0 = \frac{q_0 \cdot (1 - \nu^2) \cdot A^{0.5}}{E_s \cdot \beta_z}$$

SEquation
10.6.2.2.3b-1

Assume the footing is fully loaded, thus q_0 is the presumptive bearing capacity and effective loaded area is as calculated above

Average bearing pressure on loaded area: $q_0 = SM$

$$q_0 = 1.5 \text{TSF}$$

Effective area of footing: $A = L' \cdot B'$

Length of footing

$$L' = L \quad L' = 46.875 \text{ft}$$

Width of the footing

$$B' = B_{\min} \quad B' = 12.736 \text{ft}$$

Therefore, the Effective Area is

$$A = L' \cdot B' \quad A = 597 \text{ft}^2$$

Modulus of elasticity of soil, from Design Step P.1:

$$E_s = 60 \cdot \text{TSF}$$

Poisson's ratio of soil, from Design Step P.1:

$$\nu = 0.25$$

Shape factor for rigid footing:

$$\beta_z \text{ at } \frac{L'}{B'} = 3.681$$

From Table 10.6.2.2.3b-2 for rigid footing:

L'/B'	β_z
3	1.15
5	1.24

Table P-9 Rigid Footing

By interpolation, at $\frac{L'}{B'} = 3.681$ $\beta_z = 1.18$

$$S_0 = \frac{q_0 \cdot (1 - \nu^2) \cdot A^{0.5}}{E_s \cdot \beta_z}$$

$$S_0 = 0.49\text{ft} \quad S_0 = 5.8\text{in}$$

Note: This computation assumes an infinite depth of the compressible layer. Other computation methods that allow for the rigid base (NAVFAC DM-7.1-211) indicate the difference between assuming an infinite compressible layer and a rigid base at a depth equal to 3 times the footing width ($H/B = 3$) below the footing can be estimated by computing the ratio between appropriate influence factors (I) as follows:

As per NAVFAC DM7.1-212, and DM7.1-213:

I for rigid circular area over infinite halfspace: $I_{inf} = 0.79$

I for rigid circular area over stiff base at H/B of 3: $I_{sb} = 0.64$

The influence value determined above is for a Poisson's ratio of 0.33. A Poisson's ratio of 0.25 is used for the soil. This difference is small for the purposes of estimating elastic settlement.

STable
10.6.2.2.3b-2

Ratio of I values:

$$\frac{I_{sb}}{I_{inf}} = 0.810127$$

Since I is directly proportional to settlement, this ratio can be multiplied by S_0 to arrive at a more realistic prediction of settlement of this footing.

$$S'_0 = S_0 \cdot \frac{I_{sb}}{I_{inf}}$$

$$S'_0 = 4.718 \text{ in}$$

This settlement will occur as load is applied to the footing and may involve some rotation of the footing due to eccentricities of the applied load. Since most of the loads will be applied after construction of the abutment (backfill, superstructure, deck) this will result in unacceptable displacement.

The structural engineer has determined that the structure can accommodate up to 1.5" of horizontal displacement and up to 0.5" vertical displacement. Given the magnitude of the predicted displacements, it is unlikely this requirement can be met. Thus, a deep foundation system or some form of ground improvement is required.

Note that the above calculation did not account for the weight of the approach embankment fill and the effect that this will have on the elastic settlement. Consideration of this would increase the settlement making the decision to abandon a spread footing foundation even more decisive.

Design Step P.5 - Select Suitable Pile Type and Size

It will be assumed that for the purposes of this example, ground improvement methods such as vibro-flotation, vibro replacement, dynamic deep compaction, and others have been ruled out as impractical or too costly. It is further assumed that drilled shaft foundations have been shown to be more costly than driven pile foundations under the existing subsurface conditions (granular, water bearing strata). Thus a driven pile foundation will be designed.

Of the available driven pile types, a steel H-pile end bearing on rock is selected for this application for the following reasons.

- 1) It is a low displacement pile which will minimize friction in the overlying soils.
- 2) It can be driven to high capacities on and into the top weathered portion of the rock.
- 3) It is relatively stiff in bending thus lateral deflections will be less than for comparably sized concrete or timber piles.
- 4) Soils have not been shown to be corrosive thus steel loss is not an issue.

To determine the optimum pile size for this application, consideration is given to the following:

1) Pile diameter:

H-Piles range in size from 8 to 14 inch width. Since pile spacing is controlled by the greater of 30 inches or 2.5 times the pile diameter (D); pile sizes 12 inches and under will result in the same minimum spacing of 30 inches. Thus for preliminary analysis assume a 12 inch H-Pile.

2) Absolute Minimum Spacing:

Per referenced article, spacing is to be no less than: $2.5 \cdot D$

S10.7.1.5

Where the pile diameter: $D = 12 \cdot \text{in}$

$$2.5 \cdot D = 30 \text{ in}$$

3) Minimum pile spacing to reduce group effects:

As per FHWA-HI-96-033, Section 9.8.1.1:

Axial group effects for end bearing piles on hard rock are likely to be negligible thus axial group capacity is not a consideration. However, note that the FHWA driven pile manual recommends a minimum c-c spacing of 3D or 1 meter in granular soils to optimize group capacity and minimize installation problems. The designer's experience has shown 3D to be a more practical limit that will help avoid problems during construction.

Lateral group effects are controlled by pile spacing in the direction of loading and perpendicular to the direction of loading.

From Reese and Wang, 1991, Figure 5.3 (personal communication):

For spacing perpendicular to the direction of loading 3D results in no significant group impacts.

As per FHWA-HI-96-033, Section 9.8.4 & NACVFAC DM7.2-241:

For spacing in the direction of loading, various model studies indicate that group efficiency is very low at 3D spacing, moderate at about 5D spacing and near 100% for spacings over about 8D. Thus it is desirable to maintain at least 5D spacing in the direction of the load and preferable to maintain 8D spacing.

Maximum pile spacing

Spacing the piles more than 10 feet c-c results in higher bending moments in the pile cap between each pile and negative bending moments over the top of each pile that may result in additional steel reinforcing or thicker pile caps. Thus it is desirable to keep the pile spacing less than 10 feet c-c.

4) Edge clearance

Referenced section indicates minimum cover: $cover_{min} = 9\text{-in}$

S10.7.1.5

Thus for a 12 inch pile, minimum distance from edge of footing to center of pile:

$$dist_{min} = cover_{min} + \frac{D}{2}$$

$$dist_{min} = 1.25\text{ft}$$

5) Maximum pile cap dimensions

The length of the pile cap in the direction perpendicular to the centerline (L) is limited to the width of the abutment. Thus:

From Design Step P.4:

$$L_{max} = L$$

$$L_{max} = 46.875\text{ft}$$

The width of the pile cap in the direction parallel to the centerline of the bridge (B) can generally be made wider as required. Initial loadings were developed assuming a width of 10.25 FT thus use this dimension as a starting point.

$$B = 10.25\text{-ft}$$

Determine the maximum and minimum number of piles that can be placed beneath the cap (See sketch below for definition of variables)

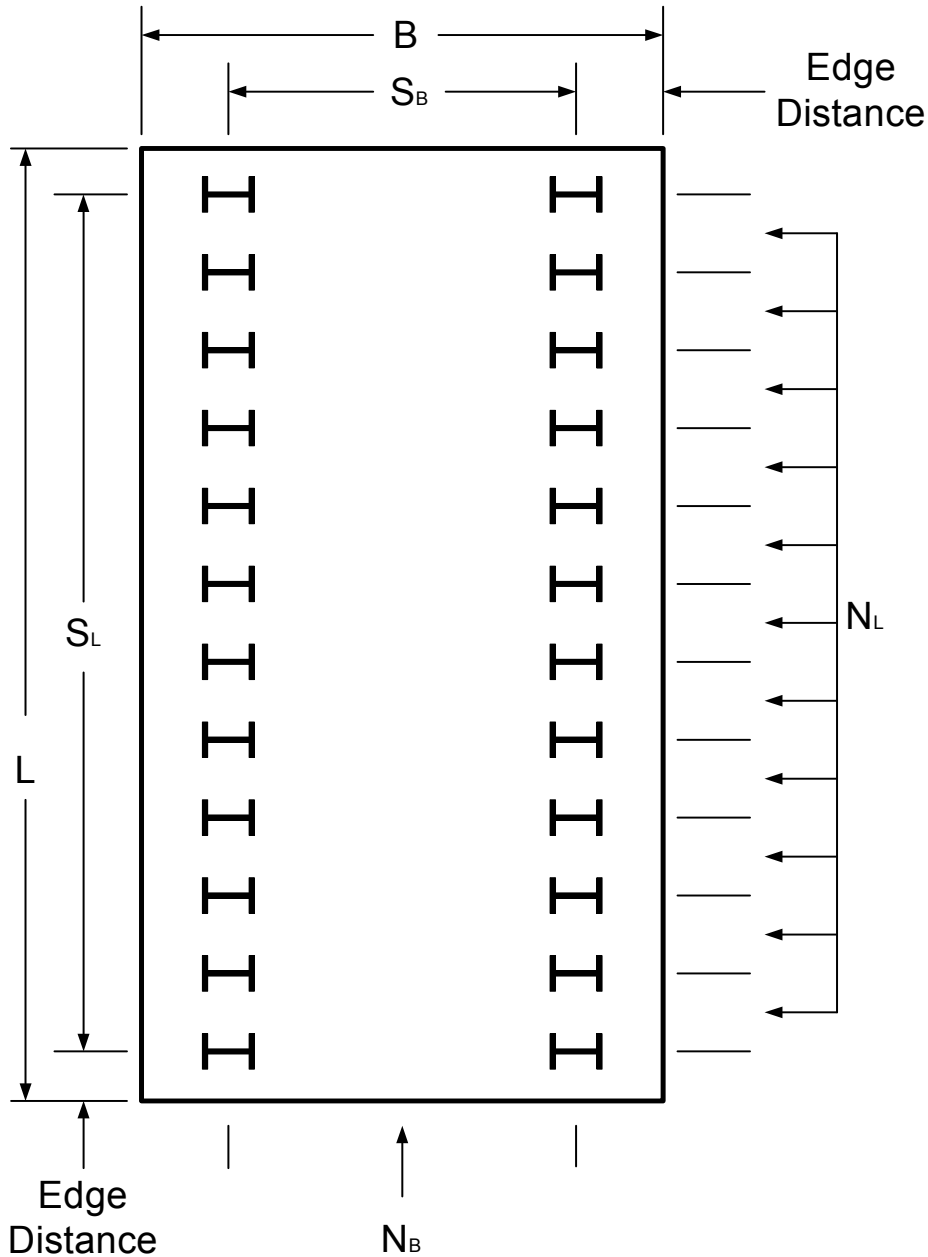

Figure P-3 Plan View of Pile Cap

In B direction:

S_B is defined as: Width of the pile cap - 2 times the edge distance

$$S_B = B - 2 \cdot \text{dist}_{\min}$$

$$S_B = 7.75 \text{ ft}$$

Max number of spaces at 5D spacing (N_B)

$$N_B < \frac{S_B}{5 \cdot D}$$

$$\frac{S_B}{5 \cdot D} = 1.55$$

$$N_B < 1.55$$

Minimum number of spaces at 10' each (N_B)

$$N_B > \frac{S_B}{10 \cdot \text{ft}}$$

$$\frac{S_B}{10 \cdot \text{ft}} = 0.775$$

$$N_B > 0.775$$

Since the number of spaces has to be an integer

$$N_B = 1$$

Which results in two rows of piles in the B direction.

In L direction:

S_L is defined as: Width of the pile cap - 2 times the edge distance

$$S_L = L - 2 \cdot \text{dist}_{\min}$$

$$S_L = 44.375 \text{ ft}$$

Max number of spaces at 3D spacing (N_L)

$$N_L < \frac{S_L}{3 \cdot D}$$

$$\frac{S_L}{3 \cdot D} = 14.792$$

$$N_L < 14.792$$

Minimum number of spaces at 10' each (N_L)

$$N_L > \frac{S_L}{10 \cdot \text{ft}}$$

$$\frac{S_L}{10 \cdot \text{ft}} = 4.438$$

$$N_L > 4.438$$

Since the number of spaces has to be an integer

$$N_L = 5 \text{ to } 14$$

Which results in 6 to 15 rows of piles in the L direction.

Determine maximum axial load acting on piles

Using factored loads and diagram below, determine reactions on the front and back pile rows:

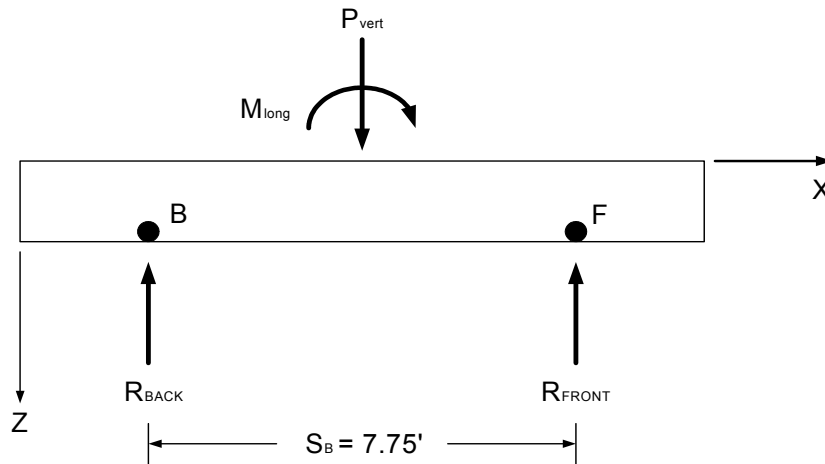

Figure P-4 Section View of Pile Cap

Summing the forces in the z-direction and the moments about point B:

$$\Sigma F_z = 0 \quad \Sigma F_z = P_{\text{vert}} - R_{\text{BACK}} - R_{\text{FRONT}}$$

$$\Sigma M_B = 0 \quad \Sigma M_B = -M_{\text{long}} - \frac{S_B}{2} \cdot P_{\text{vert}} + S_B \cdot R_{\text{FRONT}}$$

For STR I max, from Table P.6:

$$P_{\text{vert}_1} = 2253 \cdot \text{K} \quad M_{\text{long}_1} = 7963 \cdot \text{K} \cdot \text{ft}$$

$$R_{\text{FRONT}_1} = 2119 \cdot \text{K} \quad R_{\text{BACK}_1} = 134 \cdot \text{K}$$

For STR I min, from Table P.6:

$$P_{\text{vert}_2} = 1860 \cdot \text{K} \quad M_{\text{long}_2} = 7291 \cdot \text{K} \cdot \text{ft}$$

$$R_{\text{FRONT}_2} = 1871 \cdot \text{K} \quad R_{\text{BACK}_2} = -11 \cdot \text{K}$$

Max axial load on front row of piles:

$$R_{FRONT} = \max(R_{FRONT_1}, R_{FRONT_2})$$

$$R_{FRONT} = 2119K$$

Since the front row can have 6 - 15 piles,

Max anticipated factored pile load can range between:

$$R_{FRONT6} = \frac{R_{FRONT}}{6} \quad \text{and} \quad R_{FRONT15} = \frac{R_{FRONT}}{15}$$

$$R_{FRONT6} = 353.167K \quad R_{FRONT15} = 141.267K$$

Assuming the following:

Axial pile resistance is controlled by structural resistance

Structural resistance $P_r = \phi_c \cdot F_y \cdot A_s$

NOTE: λ in equation 6.9.4.1-1 is assumed to be zero (because unbraced length is zero) resulting in the simplified equation shown above.

$$\phi_c = 0.6$$

$$F_y = 36 \cdot \text{ksi}$$

NOTE: Grade 36 steel is assumed at this stage even though most H-pile sections are available in higher grades at little or no cost differential. The need for using a higher strength steel will be investigated in future design steps

*SEquation
6.9.2.1-1 and
SEquation
6.9.4.1-1*

S6.5.4.2

Compute required pile area to resist the anticipated maximum factored pile load. The required steel area can range between:

$$\frac{\left(\frac{R_{\text{FRONT6}}}{\phi_c} \right)}{F_y} = 16.35 \text{ in}^2 \quad \text{and} \quad \frac{\left(\frac{R_{\text{FRONT15}}}{\phi_c} \right)}{F_y} = 6.54 \text{ in}^2$$

For preliminary layout and design, select: HP 12x53

Properties of HP 12x53:

$$A_s = 15.5 \cdot \text{in}^2$$

$$d = 11.78 \cdot \text{in}$$

$$b_f = 12.045 \cdot \text{in}$$

$$t_f = 0.435 \cdot \text{in}$$

$$t_w = 0.435 \cdot \text{in}$$

$$I_{xx} = 393 \cdot \text{in}^4$$

$$I_{yy} = 127 \cdot \text{in}^4$$

$$Z_x = 74 \cdot \text{in}^3$$

$$Z_y = 32.2 \cdot \text{in}^3$$

$$E_s = 29000 \cdot \text{ksi}$$

Note: Plastic section modulus is used to evaluate nominal moment capacity

**Design Step P.6 - Determine Nominal Axial Structural Resistance
for Selected Pile Type / Size**

Ultimate axial compressive resistance is determined in accordance with either equation 6.9.4.1-1 or 6.9.4.1-2. The selection of equation is based on the computation of l in equation 6.9.4.1-3 which accounts for buckling of unbraced sections. Since the pile will be fully embedded in soil, the unbraced length is zero and therefore l is zero. Based on this this, use equation 6.9.4.1-1 to calculate the nominal compressive resistance.

$$P_n = 0.66^{\lambda} \cdot F_y \cdot A_s$$

where:

$$F_y = 36 \text{ ksi}$$

$$A_s = 15.5 \text{ in}^2$$

$$\lambda = 0$$

Therefore:

$$P_n = 0.66^{\lambda} \cdot F_y \cdot A_s$$

$$P_n = 558 \text{ K}$$

S6.9.4.1

SEquation
6.9.4.1-1

Design Step P.7 - Determine Nominal Axial Geotechnical Resistance for Selected Pile Type / Size

Geotechnical axial resistance for a pile end bearing on rock is determined by the CGS method outlined in 10.7.3.5

Nominal unit bearing resistance of pile point, q_p

$$q_p = 3 \cdot q_u \cdot K_{sp} \cdot d$$

SEquation
10.7.3.5-1

for which:

$$K_{sp} = \frac{3 + \frac{s_d}{D}}{10 \cdot \left(1 + 300 \frac{t_d}{s_d}\right)^{0.5}}$$

SEquation
10.7.3.5-2

$$d = 1 + 0.4 \cdot \frac{H_s}{D_s} \quad d < 3.4$$

where:

Average compressive strength of rock core:

From Design Step P.1: $q_u = q_{uave}$

$$q_u = 11485 \text{ psi}$$

Spacing of discontinuities:

Based on high observed RQD in Design Step P.1 and description of rock:

$$s_d = 1 \cdot \text{ft}$$

Width of discontinuities:

Joints are tight as per discussion in Design Step P.1:

$$t_d = 0 \cdot \text{ft}$$

Pile width:

$$\text{HP 12x53 used: } D = 1 \text{ ft}$$

Depth of embedment of pile socketed into rock:

$$\text{Pile is end bearing on rock: } H_s = 0 \cdot \text{ft}$$

Diameter of socket:

$$\text{Assumed but does not matter since } H_s = 0: D_s = 1 \cdot \text{ft}$$

so:

$$K_{sp} = \frac{3 + \frac{s_d}{D}}{10 \cdot \left(1 + 300 \frac{t_d}{s_d}\right)^{0.5}}$$

$$K_{sp} = 0.4$$

and:

$$d = 1 + 0.4 \cdot \frac{H_s}{D_s}$$

$$d = 1$$

Thus:

$$q_p = 3 \cdot q_u \cdot K_{sp} \cdot d$$

$$q_p = 1985 \text{ KSF}$$

Nominal geotechnical resistance (Q_p):

$$Q_p = q_p \cdot A_p$$

SEquation
10.7.3.2-3

where:

Nominal unit bearing resistance as defined above: $q_p = 1985 \text{ KSF}$

Area of the pile tip:

Area determined assuming a plug develops between flanges of the H-Pile. This will be the case if the pile is driven into the upper weathered portion of the rock.

$$A_p = 1 \cdot \text{ft}^2$$

Therefore:

$$Q_p = q_p \cdot A_p$$

$$Q_p = 1985 \text{ K}$$

**Design Step P.8 - Determine Factored Axial Structural
Resistance for Single Pile**

Factored Structural Resistance (P_r):

$$P_r = \phi_c \cdot P_n$$

*SEquation
6.9.2.1*

where:

Resistance factor for H-pile in compression,
no damage anticipated:

$$\phi_c = 0.6$$

S6.5.4.2

Nominal resistance as computed in Design
Step P.6:

$$P_n = 558 \text{ K}$$

Therefore:

$$P_r = 334.8 \text{ K}$$

Design Step P.9 - Determine Factored Axial Geotechnical Resistance for Single Pile

Factored Geotechnical Resistance (Q_R):

$$Q_R = \phi_{qp} \cdot Q_p$$

SEquation
10.7.3.2-2

Note: remainder of equation not included since piles are point bearing and skin friction is zero.

where:

Resistance factor, end bearing on rock (CGS method): $\phi_{qp} = 0.5 \cdot \lambda_v$

STable
10.5.5-2

Factor to account for method controlling pile installation:

For this project, stress wave measurements will be specified on 2% of the piles (a minimum of one per substructure unit) and the capacity will be verified by CAPWAP analysis. Thus: $\lambda_v = 1.0$

STable
10.5.5-2

and therefore:

$$\phi_{qp} = 0.5 \cdot \lambda_v \quad \phi_{qp} = 0.5$$

Nominal resistance as computed in Design Step P.7: $Q_p = 1985 \text{ K}$

Therefore:

$$Q_r = \phi_{qp} \cdot Q_p$$

$$Q_r = 992 \text{ K}$$

Note: This is greater than the structural capacity, thus structural capacity controls.

Design Step P.10 - Check Drivability of Pile

Pile drivability is checked using the computer program WEAP. The analysis proceeds by selecting a suitable sized hammer. Determining the maximum pile stress and driving resistance (BPF) at several levels of ultimate capacity and plotting a bearing graph relating these variables. The bearing graph is then entered at the driving resistance to be specified for the job (in this case absolute refusal of 20 BPI or 240 BPF will be used) and the ultimate capacity and driving stress correlating to that driving resistance is read.

If the ultimate capacity is not sufficient, a bigger hammer is specified and the analysis is repeated.

If the driving stress exceeds the permitted driving stress for the pile, a smaller hammer is specified and the analysis is repeated.



Drivability of Piles

If a suitable hammer can not be found that allows driving the pile to the required ultimate capacity without exceeding the permissible driving stress, modification to the recommended pile type are necessary. These may include:

- Specifying a heavier pile section
- Specifying a higher yield stress for the pile steel
- Reducing the factored resistance of the pile

Develop input parameters for WEAP

Driving lengths of piles

The finished pile will likely be 32-33 feet long which includes a 1 foot projection into the pile cap and up to 1' of penetration of the pile tip into the weathered rock. Therefore assume that 35' long piles will be ordered to allow for some variation in subsurface conditions and minimize pile wasted during cut off.

Distribution and magnitude of side friction

This pile will be primarily end bearing but some skin friction in the overlying sand will develop during driving. This skin friction can be quickly computed using the FHWA computer program DRIVEN 1.0. The soil profile determined in Step P.1 is input and an HP12x53 pile selected. The pile top is set at 4 foot depth to account for that portion of soil that will be excavated for pile cap construction. No driving strength loss is assumed since the H-Pile is a low displacement pile and excess pore pressure should dissipate rapidly in the loose sand. Summary output from the program is provided below.

```

DRIVEN 1.0
PILE INFORMATION
File Type: H Pile - HP12X53
Top of Pile: 4.00 ft
Perimeter Analysis: Box
Tip Analysis: Pile Area
ULTIMATE CONSIDERATIONS
Water Table Depth At Time Of:
  - Drilling:          5.00 ft
  - Driving/Restrike  5.00 ft
  - Ultimate:         5.00 ft
Ultimate Considerations: - Local Scour:          0.00 ft
                        - Long Term Scour:       0.00 ft
                        - Soft Soil:             0.00 ft

ULTIMATE PROFILE
Layer Type Thickness Driving Loss Unit Weight Strength Ultimate Cur
1 granular 35.00 ft 0.00% 110.00 pcf 31.0/31.0 Nordlund

DRIVING - SUMMARY OF CAPACITIES
Depth Skin Friction End Bearing Total Capacity
0.01 ft 0.00 Kips 0.00 Kips 0.00 Kips
3.99 ft 0.00 Kips 0.00 Kips 0.00 Kips
4.00 ft 0.00 Kips 1.00 Kips 1.00 Kips
4.99 ft 0.64 Kips 1.25 Kips 1.90 Kips
5.01 ft 0.66 Kips 1.26 Kips 1.91 Kips
14.01 ft 9.69 Kips 2.22 Kips 11.91 Kips
23.01 ft 23.78 Kips 2.22 Kips 26.01 Kips
32.01 ft 42.94 Kips 2.22 Kips 45.16 Kips
34.99 ft 50.39 Kips 2.22 Kips 52.62 Kips

```

Figure P-5 DRIVEN 1.0 Output

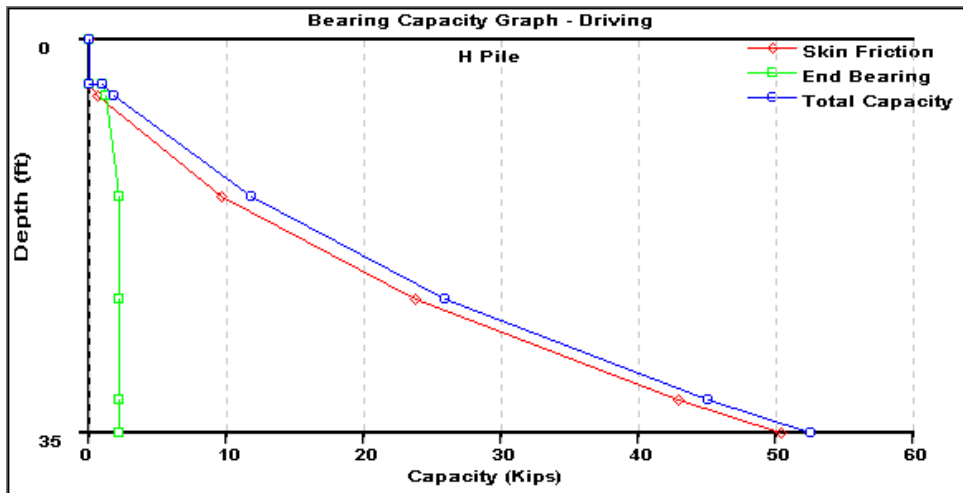

Figure P-6 Bearing Capacity

From this analysis, the side friction during driving will vary in a triangular distribution, and will be about:

$$Q_s = 50 \cdot K$$

The distribution will start 4 feet below the top of the pile which is:

$$\frac{4 \cdot \text{ft}}{35 \cdot \text{ft}} = 11\% \quad \text{below the top of the pile.}$$

The desired factored resistance was determined in Design Step P.8 and is controlled by structural resistance of the pile. This value is:

$$P_f = 334.8K$$

The ultimate resistance that must be achieved during wave equation analysis will be this value divided by the appropriate resistance factor for wave equation analysis + the estimated side friction.

NOTE: Side friction is added here because downdrag is expected to reduce or reverse the skin friction in the final condition. Therefore, sufficient point capacity must be developed during driving to adequately resist all applied loads plus the downdrag.

$$\phi = 0.65 \cdot \lambda_v$$

From Design Step P.9:

$$\lambda_v = 1$$

Thus:

$$\phi = 0.65$$

and

$$Q_p = \frac{P_r}{\phi}$$

$$Q_p = 515 \text{ K}$$

At this Ultimate point resistance the percent side friction is:

$$\frac{Q_s}{Q_s + Q_p} = 9\%$$

and the resistance required by wave equation analysis is:

$$Q_{req} = Q_s + Q_p$$

$$Q_{req} = 565 \text{ K}$$

Stable
10.5.5-2

Soil parameters (use Case damping factors):



Damping Factors

Case damping factors are used here because of experience with similar jobs. In general, Smith damping factors are preferred. In this case, the Smith damping factors would likely give very similar results to what is computed using the selected Case damping factors.

The parameters for loose sand and hard sandstone were estimated based on local experience with similar soils.

Loose Sand

Skin Damping: $S_D = 0.2 \text{ DIM}$

Skin Quake: $S_Q = 0.1 \cdot \text{in}$

Toe Damping: $T_D = 0.15 \text{ DIM}$

Toe Quake: $T_Q = 0.1 \cdot \text{in}$

Use skin damping and skin quake for pile shaft.

Hard Sandstone

Skin Damping: $S_D = 0.05 \text{ DIM}$

Skin Quake: $S_Q = 0.1 \cdot \text{in}$

Toe Damping: $T_D = 0.05 \text{ DIM}$

Toe Quake: $T_Q = 0.05 \cdot \text{in}$

Use toe damping and toe quake for pile toe.

Hammer Selection:

As a rule of thumb, start out with a rated energy of 2000 ft-lbs times the steel area of the pile.

Area: $A_s = 15.5 \text{ in}^2$ from Design Step P.5

Rated Energy: $E_r = (2000 \cdot \text{ft} \cdot \text{lb}) \cdot A_s$

$$E_r = 31000 \text{ ft} \cdot \text{lb}$$

Select open ended diesel common to area

DELMAG 12-32 (ID=37) rated at: $31.33 \cdot \text{ft} \cdot \text{K}$

Helmet weight: $2.15 \cdot \text{kip}$

Hammer Cushion Properties:

Area: $283.5 \cdot \text{in}^2$

Elastic Modulus: $280 \cdot \text{KSI}$

Thickness: $2 \cdot \text{in}$

COR: 0.8

Hammer Efficiency: 72%

Permissible Driving Stress:

Driving Stress, $S_d < 0.9 \cdot \phi \cdot F_y$

S10.7.1.16

Note that the equation above was modified to yield stress rather than load.

where:

Resistance factor for driving: $\phi = 1.0$

S6.5.4

Steel yield stress, from Design Step P.5: $F_y = 36 \text{ ksi}$

$$0.9 \cdot \phi \cdot F_y = 32.4 \text{ ksi}$$

$$S_d < 32.4 \cdot \text{ksi}$$

Summary of Wave Equations Analysis:

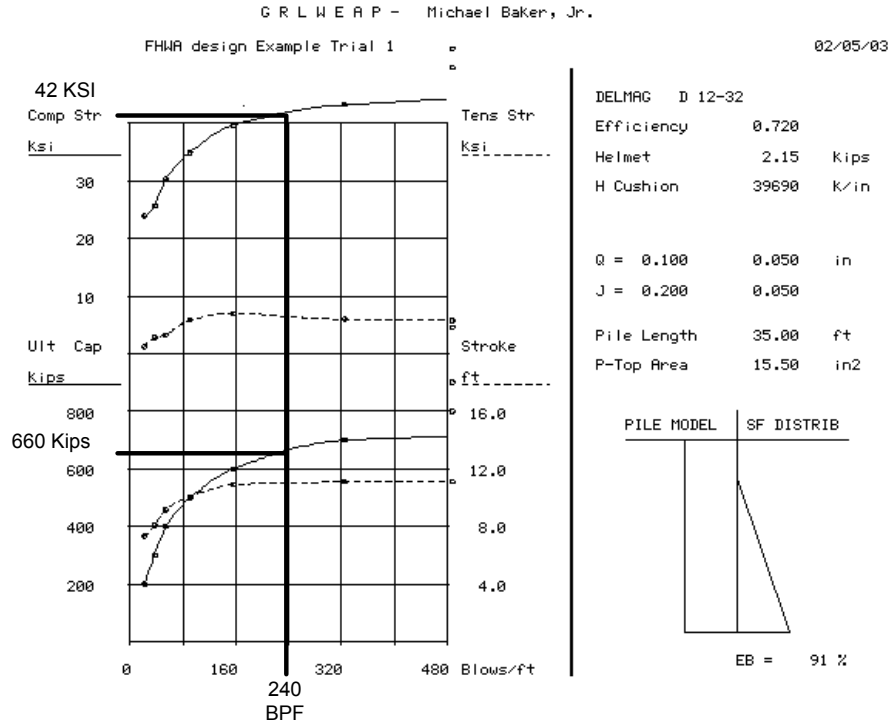

Figure P-7 Wave Equation Analysis

at refusal the pile has an ultimate capacity of $Q_{ult} = 660 \cdot K$

at refusal the driving stress in the pile is $S_{d_act} = 42 \cdot ksi$

Check:

The ultimate capacity exceeds that required

$$Q_{ult} > Q_{req}$$

$$Q_{ult} = 660 \text{ K} > Q_{req} = 565 \text{ K} \quad \text{OK}$$

The permissible driving stress exceeds the actual value

$$S_D > S_{d_act}$$

$$S_d = 32.4 \text{ ksi} > S_{d_act} = 42 \text{ ksi}$$

This condition is not satisfied - **no good.**

Try reducing hammer energy

DELMAG D 12 (ID=3) rated at 23.59·ft·kip

Hammer Cushion Properties same as before

Summary of Wave Equations Analysis:

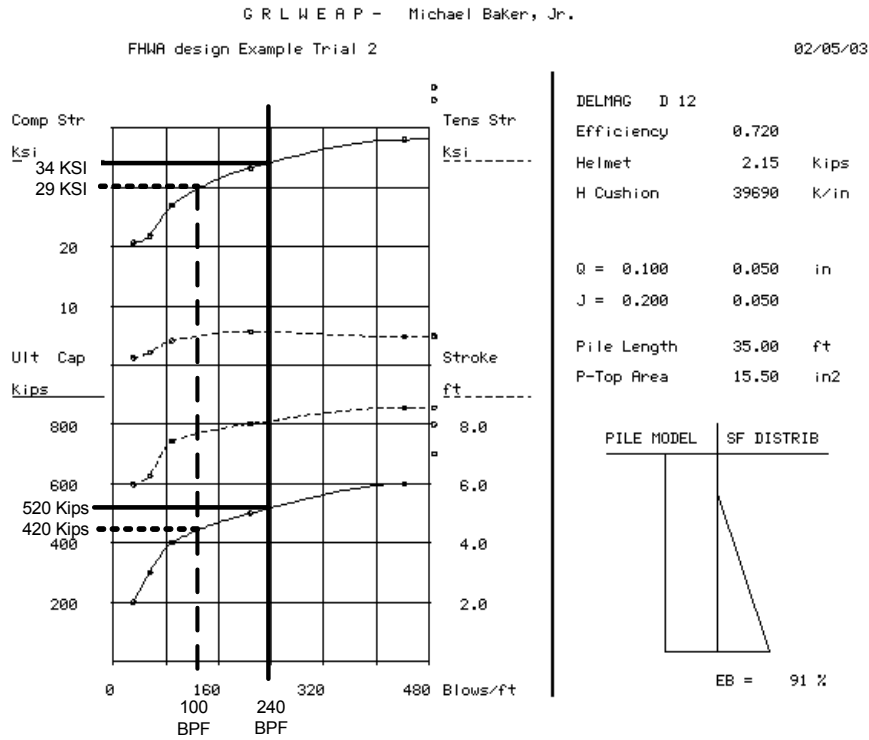

Figure P-8 Wave Equation Analysis

at refusal the pile has an ultimate capacity of $Q_{ult} = 520 \cdot K$

at refusal the driving stress in the pile is $S_{d_act} = 34 \cdot ksi$

Check:

The ultimate capacity exceeds that required

$$Q_{ult} > Q_{req}$$

$$Q_{ult} = 520 \text{ K} > Q_{req} = 565 \text{ K}$$

This condition is not satisfied - **no good**

The permissible driving stress exceeds the actual value

$$S_D > S_{d_act}$$

$$S_d = 32.4 \text{ ksi} > S_{d_act} = 34 \text{ ksi}$$

This condition is not satisfied - **no good.**

A decision must be made at this point:

Is pile drivable to minimum of Ultimate Geotechnical Axial Resistance or Ultimate Structural Resistance without pile damage?

Based on above analysis, no hammer can possibly drive this pile to the required capacity without exceeding the permissible driving stress.

There are 2 approaches to resolving this problem

- 1) Reduce the factored resistance of the pile to a value that can be achieved without over stressing the pile.

Based on the above bearing graph and allowing for some tolerance in the driving stress (requiring the contractor to select a driving system that produces exactly 32.4 KSI in the pile is unreasonable) a reasonable driven capacity is estimated. Using a minimum driving stress of 29 KSI (0.8 Fy) the penetration resistance is about 100 BPF and the ultimate capacity would be:

$$Q_{ult} = 420 \cdot K$$

This value includes skin friction during driving which was set in the program to be 9% of the ultimate resistance. Therefore, point resistance at this driving stress would be:

$$Q_p = 91\% \cdot Q_{ult} \qquad Q_p = 382.2 K$$

and:

$$\phi = 0.65$$

$$Q_R = \phi \cdot Q_p \qquad Q_R = 248.43 K$$

- 2) Increase the yield strength of the pile without increasing the previously computed factored resistance

Using grade 50 steel

$$\text{Driving Stress: } S_d < 0.9 \cdot \phi \cdot F_y$$

S10.7.1.16

(Equation modified to yield stress instead of load)

where:

$$\text{Resistance factor for driving: } \phi = 1$$

S6.5.4

$$\text{Steel yield stress: } F_y = 50 \cdot \text{ksi}$$

$$0.9 \cdot \phi \cdot F_y = 45 \text{ ksi}$$

$$S_d < 45 \cdot \text{ksi}$$

Since option 2 involves little or no additional cost and option 1 will result in significant increase in cost due to required additional piles, select option 2

In this case The Delmag 12-32 produced acceptable driving results.

It can be seen from the results of the wave equation analysis that the driving stress times the pile area is about equal to the mobilized pile capacity. Thus, if the factored structural resistance determined in step P.8 is used as the final design pile resistance, then the ultimate required dynamic capacity determined above is valid and the driving stress associated with this capacity can be estimated by:

$$\text{Driving Stress } S_d = \frac{Q_{ult}}{A_s}$$

where:

Ultimate required capacity as previously determined by wave equation analysis: $Q_{ult} = 565 \cdot K$

Pile area, from Design Step 9.5: $A_s = 15.5 \cdot \text{in}^2$

$$\text{Driving Stress } S_d = \frac{Q_{ult}}{A_s}$$

$$S_d = 36.5 \text{ ksi}$$

Thus, so long as the contractor selects a hammer that will produce a driving stress between about 37 and 45 KSI at refusal, an acceptable driven capacity should be achieved during construction.

Using a minimum driving stress of $S_{d_min} = 37 \cdot \text{ksi}$

$$Q_{ult} = S_{d_min} \cdot A_s$$

$$Q_{ult} = 573.5 K$$

$$Q_p = Q_{ult} - Q_s$$

$$Q_s = 50 K \quad \text{As defined previously}$$

$$Q_p = 523.5 K$$

Again, side friction is subtracted from the ultimate capacity since it will be present during driving but will not be present in the final condition. Resistance is based on the point resistance achieved during driving the pile to refusal.

and the minimum driven resistance is

$$Q_R = \phi \cdot Q_p$$

$$\phi = 0.65$$

$$Q_p = 523.5 \text{ K}$$

$$Q_R = \phi \cdot Q_p$$

$$Q_R = 340.275 \text{ K}$$

Recompute structural resistance based on higher yield steel, as in Design Step P.6

$$P_n = 0.66^\lambda \cdot F_y \cdot A_s$$

where

Nominal compressive resistance: P_n

$$F_y = 50 \text{ ksi}$$

$$A_s = 15.5 \text{ in}^2$$

$$\lambda = 0$$

$$P_n = 775 \text{ K}$$

SEquation
6.9.4.1-1

The factored axial structural resistance, as in Design Step P.8 is:

$$P_r = \phi_c \cdot P_n$$

$$\phi_c = 0.6$$

$$P_r = 465 \text{ K}$$

Driven capacity controls

Thus final axial resistance of driven pile:

$$Q = Q_R$$

$$Q = 340 \text{ K}$$

SEquation
6.9.2.1-1

Design Step P.11 - Do Preliminary Pile Layout Based on Factored Loads and Overturning Moments

The purpose of this step is to produce a suitable pile layout beneath the pile cap that results in predicted factored axial loads in any of the piles that are less than the final factored resistance for the selected piles. A brief evaluation of lateral resistance is also included but lateral resistance is more fully investigated in step P.13

The minimum number of piles to support the maximum factored vertical load is:

$$N = \frac{P_{\text{vert}}}{Q_R}$$

where:

The maximum factored vertical load on the abutment, from Design Step P.3, Load Case STR I max: $P_{\text{vert}} = 2253 \cdot K$

The final controlling factored resistance for the selected pile type, from Design Step P.10: $Q_R = 340 K$

$$P_f = Q_R$$

$$N = \frac{P_{\text{vert}}}{P_f}$$

$$N = 6.6 \text{ Piles}$$

Additional piles will be required to resist the over turning moment.

From Design Step P.5, the maximum load that needed to be supported by each row of piles was calculated.

$$R_{\text{FRONT}} = 2119K$$

$$R_{\text{BACK}} = 134 \cdot K$$

The required number of piles in the front row is determined as above.

$$N_{\text{FRONT}} = \frac{R_{\text{FRONT}}}{P_f}$$

$$N_{\text{FRONT}} = 6.2 \text{ Piles}$$

Additional load in the corner pile will come from the lateral moment but this is small, so start with 7 piles in the front row.

$$N_{\text{FRONT}} = 7 \text{ Piles}$$

This results in a pile spacing of:

$$\text{c-c spacing of piles: } s = \frac{S_L}{N_{\text{FRONT}}}$$

where:

The length of footing available for piles, from Design Step P.5: $S_L = 44.375 \text{ ft}$

$$\text{c-c spacing of piles: } s = \frac{S_L}{N_{\text{FRONT}} - 1}$$

$$s = 7.396 \text{ ft}$$

Set c-c spacing of piles = 7' 4"

This is approaching the maximum pile spacing identified in Step 5 thus set the back row of piles to the same spacing. This will result in the back row of piles being under utilized for axial loads. However, the additional piles are expected to be necessary to help handle lateral loads and to resist downdrag loads that will be applied to the back row only. Further, a load case in which the longitudinal loads such as temperature and braking loads are reversed will increase the loads on the back row.

Thus, the final preliminary layout is diagramed below

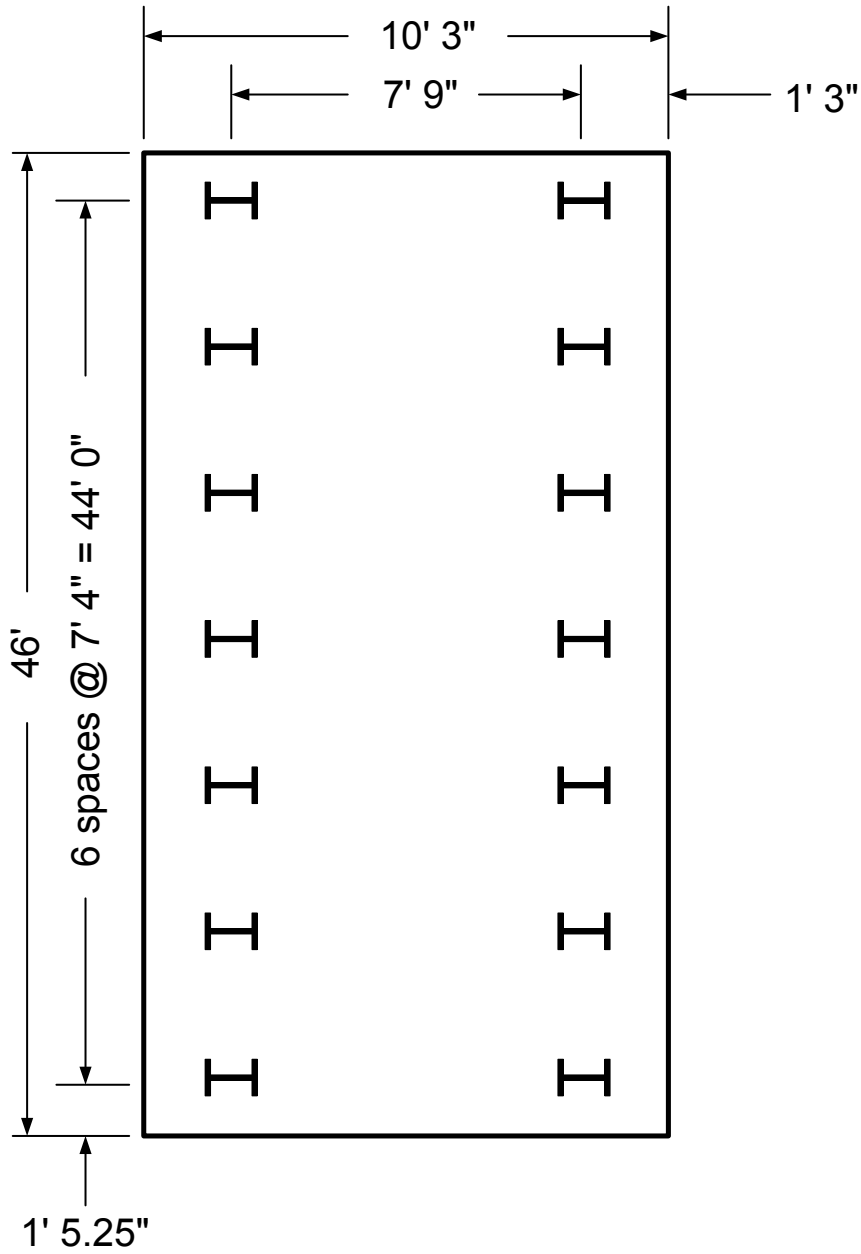

Figure P-9 Plan View of Pile Cap

The spreadsheet below is used to calculate individual pile loads using the following formula:

$$P = \frac{F'_z}{N} + M'_x \cdot \frac{x'}{I_{yy}} + M'_y \cdot \frac{y'}{I_{xx}}$$

where:

Vertical load and moments applied at the centroid of the pile group: F'_z, M'_x, M'_y

Distance from centroid of pile group to pile in the x and y directions: x', y'

Moment of inertia of the pile group about the y and x axis respectively: I_{yy}, I_{xx}

Calculation of Individual Pile Loads on an Eccentrically Loaded Footing:

Input Applied Loads:

At $x = 0, y = 0$

$F_z = -2253 \cdot K$

$M_x = 0 \cdot K \cdot ft$

$M_y = 7693 \cdot K \cdot ft$

The coordinate system for the following calculations is provided in Figure P.10:

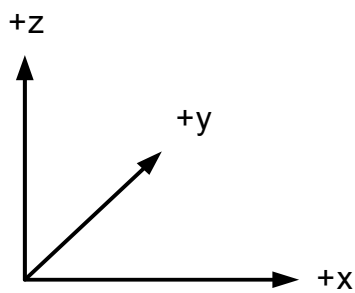

Figure P-10 Coordinate System

Table P-10 is used to calculate the vertical load and moments, and the moment of inertia of the pile group.

Input Pile Location			Calculated Values				
Pile Number	x	y	x'	y'	x' ²	y' ²	Pile load
1	-3.875	-22	-3.875	-22	15.01563	484	-19.1221
2	3.875	-22	3.875	-22	15.01563	484	-302.735
3	-3.875	-14.6667	-3.875	-14.6667	15.01563	215.111	-19.1221
4	3.875	-14.6667	3.875	-14.6667	15.01563	215.111	-302.735
5	-3.875	-7.33333	-3.875	-7.33333	15.01563	53.7778	-19.1221
6	3.875	-7.33333	3.875	-7.33333	15.01563	53.7778	-302.735
7	-3.875	0	-3.875	0	15.01563	0	-19.1221
8	3.875	0	3.875	0	15.01563	0	-302.735
9	-3.875	7.33333	-3.875	7.33333	15.01563	53.7778	-19.1221
10	3.875	7.33333	3.875	7.33333	15.01563	53.7778	-302.735
11	-3.875	14.6667	-3.875	14.6667	15.01563	215.111	-19.1221
12	3.875	14.6667	3.875	14.6667	15.01563	215.111	-302.735
13	-3.875	22	-3.875	22	15.01563	484	-19.1221
14	3.875	22	3.875	22	15.01563	484	-302.735

Table P-10 Pile Calculations

Sum of the distances in the x direction is zero.

Sum of the distances in the y direction is zero.

Centroids:

$$y_c = 0 \cdot \text{in}$$

$$x_c = 0 \cdot \text{in}$$

Moment of Inertia about the y axis: $I_{yy} = 210.2188 \cdot \text{in}^4$

Moment of Inertia about the x axis: $I_{xx} = 3011.556 \cdot \text{in}^2$

Resolved loads at Centroid:

$$F'_z = F_z$$

$$F'_z = -2253 \text{ K}$$

$$M'_x = -F'_z \cdot y_c + M_x$$

$$M'_x = 0 \text{ K}\cdot\text{ft}$$

$$M'_y = -F'_z \cdot x_c + M_y$$

$$M'_y = 7693 \text{ K}\cdot\text{ft}$$

Summary of individual pile loads for all load cases:

This table was generated by inserting each load case in the spreadsheet above and recording the resulting pile loads for that load combination.

Load Case	STR-I MAX/FIN	SER-I MAX/FIN	STR-I MIN/FIN	SER-I MIN/FIN	STR-III MAX/FIN	SER-I MAX/FIN
Fz =	-2253	-1791	-1860	-1791	-1815	-1791
Mx =	0	162	0	162	508	162
My =	7693	4774	7291	4709	6374	4774
Pile No.						
1	-19.1	-41.1	1.5	-42.3	-15.9	-41.1
2	-302.7	-217.1	-267.3	-215.9	-250.8	-217.1
3	-19.1	-40.7	1.5	-41.9	-14.6	-40.7
4	-302.7	-216.7	-267.3	-215.5	-249.6	-216.7
5	-19.1	-40.3	1.5	-41.5	-13.4	-40.3
6	-302.7	-216.3	-267.3	-215.1	-248.4	-216.3
7	-19.1	-39.9	1.5	-41.1	-12.1	-39.9
8	-302.7	-215.9	-267.3	-214.7	-247.1	-215.9
9	-19.1	-39.5	1.5	-40.7	-10.9	-39.5
10	-302.7	-215.5	-267.3	-214.3	-245.9	-215.5
11	-19.1	-39.1	1.5	-40.3	-9.7	-39.1
12	-302.7	-215.1	-267.3	-213.9	-244.7	-215.1
13	-19.1	-38.7	1.5	-39.9	-8.4	-38.7
14	-302.7	-214.7	-267.3	-213.5	-243.4	-214.7
Maximum	-302.7	-217.1	-267.3	-215.9	-250.8	-217.1
Minimum	-19.1	-38.7	1.5	-39.9	-8.4	-38.7

Table P-11 Individual Loads for All Load Cases

Pile loads range between -302.7 K in compression and 1.5 K in tension for all load cases.

The maximum compressive load is reasonably close to the factored resistance for the selected pile and the tension load is minimized thus this is a reasonable layout with respect to axial load.

Evaluate lateral loads:

If all piles are vertical they can all be assumed to take an equal portion of the applied horizontal load since group effects have been minimized by keeping the pile spacing large enough.

The controlling criterion with respect to horizontal loads on vertical piles is usually deflection which is a service load case. Looking at the maximum horizontal loads in section P.3, it can be seen that the transverse loads are relatively small and can be ignored for the purposes of this step. The maximum longitudinal service load is:

$$P_{\text{long}} = 571 \cdot K$$

Number of piles: $N_{\text{pile}} = 14$

Thus, load per pile: $P = \frac{P_{\text{long}}}{N_{\text{pile}}}$

$$P = 40.8K$$



Lateral Capacity

The design chart used below to estimate the lateral capacity of steel H-Piles is one of many methods available to the designer. Brohms method can be used to estimate ultimate capacity (strength limit state) and various published elastic solutions may be used to estimate deflection (service limit state). Presumptive allowable lateral capacities based on the designer's experience (service limit state) may be used or a preliminary P-y analysis using COM624 may be performed at this point to assist in initial pile group layout

Based on the design chart below, the maximum service load per pile for an assumed 1.5" deflection (38mm) is:

92KN = 20.6K

From PennDOT DM4 Appendix F-20:

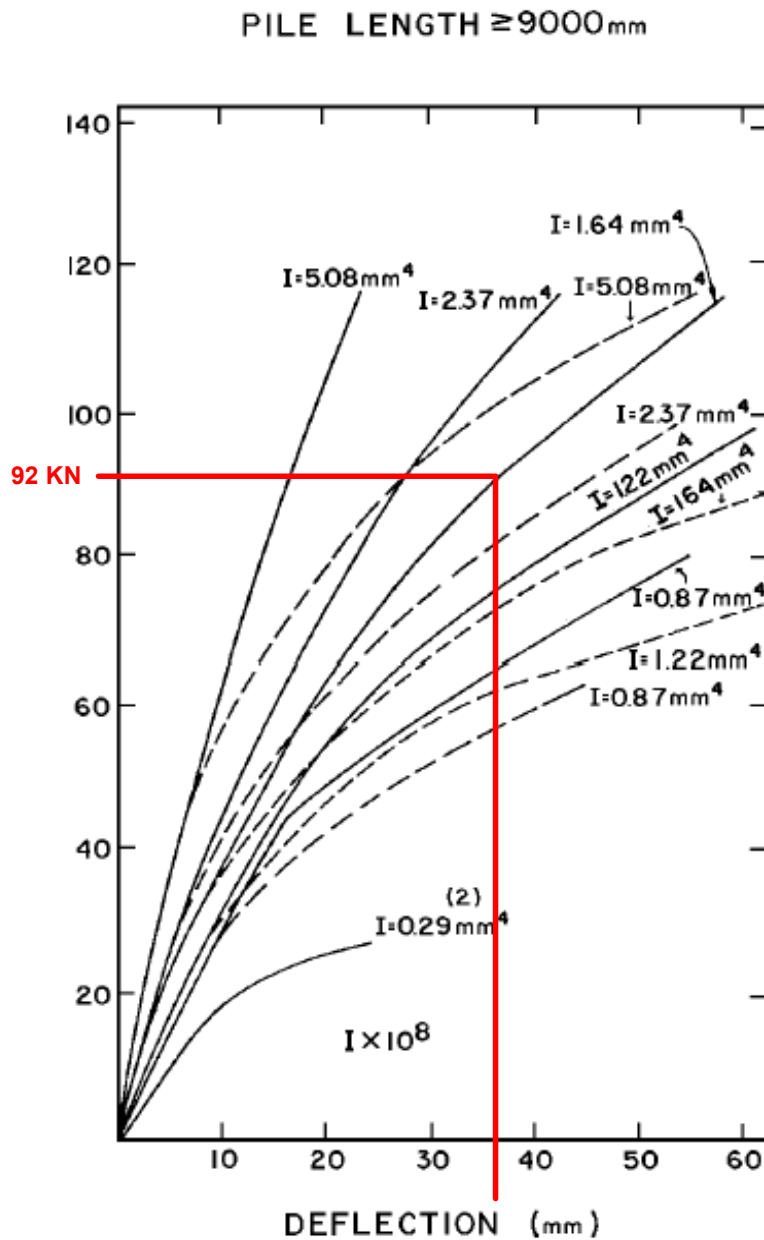

Figure P-11 Maximum Service Load Per Pile

Notes on chart:

Solid lines represent load vs deflection for full depth loose saturated sand

I values are moment of inertia for pile about axis perpendicular to applied load (shown in $\text{mm}^4 \times 10^8$)

For HP 12 x 53

$$I_{xx} = 393 \cdot \text{in}^4$$

$$I_{xx} = 1.636 \times 10^8 \text{mm}^4$$

Load in KN is applied at ground surface and pile head is assumed to be 50% fixed

Thus, there probably will not be sufficient lateral load capacity with 14 vertical piles. To resolve this, it will be necessary to add more piles or batter some of the piles. Since at least twice as many piles would be required to handle the anticipated horizontal loads, battering the piles makes more sense.

Investigate battering front row of piles at 1:3 (back row of piles not battered due to lack of vertical load and potential for downdrag)

Total vertical load on front row for each of the load cases is computed by summing the individual pile loads computed above.

From Design Step P.3:

Load Case	STR-I MAX/FIN	SER-I MAX/FIN	STR-I MIN/FIN	SER-I MIN/FIN	STR-III MAX/FIN	SER-I MAX/FIN
Total vertical load on front row of piles (kips)	2119.1	1511.5	1870.8	1503.1	1730.0	1511.5
Batter = 0.333333333						
Available resisting force due to horizontal component of axial pile load = Batter x vertical load on front row (kips)	706.4	503.8	623.6	501.0	576.7	503.8
P_{long} = (kips)	855.0	571.0	855.0	568.0	787.0	571.0
Remaining force to be handled by bending of pile = P_{long} - available horizontal force (kips)	148.6	67.2	231.4	67.0	210.3	67.2
Force per pile (kips)	10.6	4.8	16.5	4.8	15.0	4.8

Table P-12 Vertical Load on Front Row of Piles for Each Load Case

The remaining force per pile to be handled in bending is in the reasonable range thus this may be a workable configuration but it must be confirmed by interaction analysis. Thus proceed to next step with a 14 pile group with the front row battered at 3V:1H.

Design Step P.12 - Evaluate Pile Head Fixity

The performance of the pile group and the resulting pile stresses are greatly influenced by the degree to which piles are fixed against rotation at the pile head. This fixity is provided by the pile cap and is a function of the embedment of the pile into the cap, the geometry of the pile group, the stiffness of the pile cap, and the deflection. Each of these is evaluated below.

S10.7.3.8

Embedment

Research has shown that a pile needs to be embedded 2-3 times its diameter into the pile cap in order to develop full fixity. These piles will be embedded the minimum of 1 foot since the thickness of the pile cap is expected to be only 2.5 feet. Embedding the piles 2 feet into a 2.5 thick cap places the tops of the piles near the top layer of reinforcing and increases the probability of the pile punching through the top of the cap under load. Thus full pile head fixity will likely not develop regardless of other factors.

S10.7.1.5

Group geometry

In the transverse direction, there will be 7 rows of piles that when deflected force the pile cap to remain level. This condition will result in full fixity of the pile head pending evaluation of other factors. In the longitudinal direction there will be only 2 rows of piles which should be sufficient to enforce fixity pending evaluation of other factors. However, if the front row of piles is battered and the back row of piles is left vertical, the pile cap will tend to rotate backwards as it deflects. This could conceivably result in a moment applied to the pile heads greater than that required to fix the head (i.e. greater than 100% fixity) This backwards rotation of the pile cap is accounted for in the group analysis so it does not need to be considered here.

Pile cap stiffness

Flexing of the pile cap due to applied loads and moments tends to reduce the fixity at the head of the pile. In this case the pile cap is expected to be relatively thin so this effect becomes important. The stiffness of the pile cap is accounted for in the group interaction analysis so this does not effect the evaluation of fixity.

Deflection

The fixity of a pile is reduced at large deflections due to cracking of the concrete at the bottom of the pile cap. For the vertical pile group deflections are expected to be large but for the battered group deflections are likely to be small.

Conclusion

Since the group analysis will account for the group geometry and the stiffness of the pile cap, the remaining factors of embedment and deflection need to be accounted for. Both of these indicate that pile head fixity is likely to be somewhere between 25 and 75% with the higher values for the battered group. To be conservative, the group will be analyzed with 0 and 100% fixity to determine the critical conditions for pile stress (usually 100% fixity) and deflection (0 % fixity)

Design Step P.13 - Perform Pile Soil Interaction Analysis

Group interaction analysis will be performed using the computer program FB-Pier developed by FHWA, FloridaDOT and University of Florida. This program is available from the Bridge Software Institute associated with the University of Florida. Version 3 of the program is used in this example.

S10.7.3.11

In order to properly use the program, a few additional soil and pile cap properties need to be established. These are:

- 1) The location and thickness of the abutment stem. This controls the relative stiffness of the pile cap.
- 2) The location and distribution of applied loads.
- 3) The axial response of the soil and rock (T-z and Q-z)
- 4) The lateral response of soil (P-y)
- 5) The torsional response of the soil and rock (T- q)
- 6) Other miscellaneous considerations

Each is evaluated below:

Location and thickness of stem.

Previous analysis has developed a preliminary stem thickness of 3.5 feet located 2.75' from the toe of the footing. The stem is 15' tall thus the footing will be thickened to 15' in this zone as shown on the sketch below:

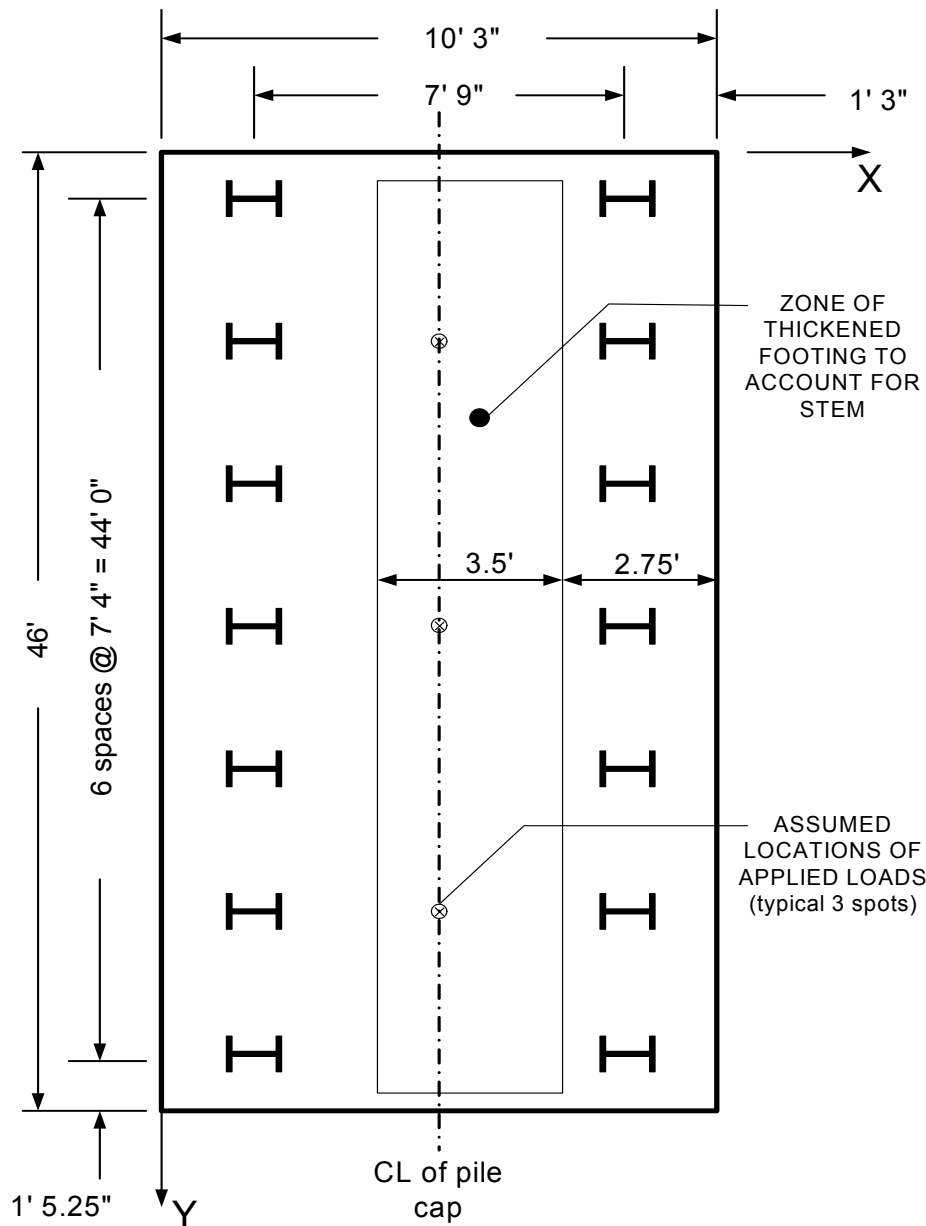

Figure P-12 Location and Thickness of Stem

Location of applied loads

The loads as supplied so far were resolved to a point at the center of the footing and the bottom of the pile cap. The loads actually consist of numerous loads due to earth pressure, superstructure, self weight etc. that are distributed over the proposed structure. To simplify the analysis, only the pile cap will be modeled in FB-Pier. The supplied loads will be divided by 3 and applied to the pile cap at 3 locations along the length of the stem at the centerline of the pile group. Since the cap will be modeled as a membrane element at an elevation that corresponds to the base of the pile cap and the loads were supplied at the base of the pile cap, no additional changes to the supplied loads and moments are required. The assumed locations of the applied loads are shown above.

The magnitude of loads and moments are computed from those provided in section P.3 as shown below. The terminology and sign convention has been converted to that used in FB-Pier. The coordinate system used is a right handed system as shown in the sketch above with Z pointing down.

Note the loads at each point provided below are in Kip-FT units

LIMIT STATE	FB-Pier Load Case	Fz (K)	My (K-FT)	Mx (K-FT)	Fx (K)	Fy (K)
STR-I MAX/FIN	1	751.0	-2564.3	0.0	285.0	0.0
SER-I MAX/FIN	2	597.0	-1591.3	54.0	190.3	3.3
STR-I MIN/FIN	3	620.0	-2430.3	0.0	285.0	0.0
SER-I MIN/FIN	4	597.0	-1569.7	54.0	189.3	3.3
STR-III MAX/FIN	5	605.0	-2124.7	169.3	262.3	12.3
SER-I MAX/FIN	6	597.0	-1591.3	54.0	190.3	3.3

Table P-13 Loads for Each Limit State

The axial response of the soil and rock (T-z and Q-z)

Since the piles will be point bearing, friction response of the soil will be small compared to the point resistance and can be ignored. However, for cases that develop tension in the piles, frictional response of the soil will be the only thing that resists that tension. Therefore, two cases will need to be run, one with the frictional response set to zero by specifying a custom T-z curve and the second with the friction response set to the default for a driven pile in granular material.

Point response of the pile bearing on rock (Q-z) will be a function of the elastic properties of the rock and will be input as a custom Q-z curve as defined below.

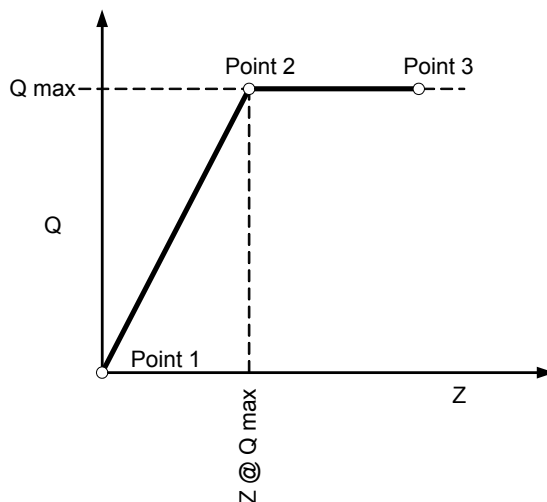

Figure P-13 Q-z Curve

From Design Step P.7:

$$Q_{\max} = 1985 \cdot K$$

$z @ Q_{\max}$ is estimated using the methods for a drilled shaft socketed in rock.

$$z @ Q_{\max}: \quad \rho_{\text{base}} = \frac{\sum P_i \cdot l_p}{D_s \cdot E_r}$$

CEquation
10.8.3.5-2

where:

Load at top of socket: $\Sigma P_i = 992 \cdot \text{ton}$

Since $\frac{H_s}{D_s} = 0$

Influence coefficient (DIM): $I_p = 1.1 \text{ DIM}$

Diameter of socket,
for HP12 pile: $D_s = 1 \cdot \text{ft}$

Modulus of elasticity of rock mass (TSF): E_r

where:

Modulus modification ratio based on
RQD, from Design Step P.1: $RQD = 90.4\%$

$$K_e = 0.74$$

Modulus of elasticity of intact rock,
from Design Step P.1: $E_i = 153000 \cdot \text{TSF}$

Thus,

$$E_r = K_e \cdot E_i$$

$$E_r = 113220 \text{ TSF}$$

and:

$$\rho_{\text{base}} = \frac{\Sigma P_i \cdot I_p}{D_s \cdot E_r}$$

$$\rho_{\text{base}} = 0.009638 \text{ ft}$$

$$\rho_{\text{base}} = 0.11565 \text{ in}$$

CFigure
10.8.3.5-1

CFigure
10.8.3.5-3

CEquation
10.8.3.5-3

Thus Q-z curve is defined by the following points

(refer to the sketch above for location of the points)

Point	Q (kips)	z (IN)
1	0	0.00
2	1985	0.12
3	1985	2.00

Table P-14 Q-z Curve Points

The lateral response of soil and rock (P-y)

For Soil, use built in P-y curve for sand (Reese) with

$$\phi'_f = 31^\circ$$

$$Y_{\text{wet}} = 110 \text{ PCF}$$

$$k = 20 \text{ psi}$$

Assume pile will drive into top weathered portion of rock estimated to be 1' thick.

The embedment of the pile into the rock will provide some amount of lateral restraint at the pile tip. The response of the rock will be relatively stiff compared to the soil. To simulate this response, use the built in P-y curve for a stiff clay above the water table since the shape of this curve is closest to actual rock response. Input parameters for this curve are estimated below:

Shear strength

Average q_u ,
Design Step P.1: $q_{u\text{ave}} = 11485 \text{ psi}$

$$q_{u\text{ave}} = 1653840 \text{ PSF}$$

Arbitrarily reduce to 10% of this value to account for weathering

10% of Average q_u : $10\% \cdot q_u = 165384 \text{ PSF}$

Shear strength, $1/2 q_u$: $\frac{1}{2} \cdot (10\% q_u) = 82692 \text{ PSF}$

Say shear strength: $q_u = 80000 \cdot \text{PSF}$

Unit weight

Average γ ,
Design Step P.1: $\gamma_{ave} = 150 \text{ PCF}$

Strain at 50% ultimate shear strength (ϵ_{50})

$$\epsilon_{50} = 0.002$$

This is based on experience with similar rocks or it can be determined from the results of the unconfined tests if stress and strain data was recorded during the test.

The torsional response of the soil and rock (T- q)

From Design Step P.1:

$$\phi'_f = 31^\circ$$

$$\gamma_{wet} = 110 \text{ PCF}$$

$$G_o = 0.33 \cdot \text{ksi}$$

From Design Step P.10:

$$T_{max} = 417 \cdot \text{PSF}$$

Note: T_{max} calculated as the total skin friction calculated by DRIVEN analysis divided by surface area of pile embedded in soil during that analysis. This represents an average value along the length of the pile and is not truly representative of the torsional response of the pile. However, a more sophisticated analysis is not warranted since torsional response of the piles will be minimal in a multi pile group that is not subject to significant eccentric horizontal loading.

Miscellaneous other considerationsModulus of elasticity of concrete in pile cap

Assume pile cap is constructed of concrete with $f_c = 3000$ psi

Then, modulus of elasticity of concrete

$$E_c = 57000 \cdot f_c^{0.5}$$

$$E_c = 3122019 \text{ psi}$$

$$E_c = 3122.019 \cdot \text{ksi}$$

Poisson's ratio for concrete

Assume:

$$\nu_c = 0.2$$

Pile lengths

Since top of rock is level and front row of piles is battered, front row of piles will be slightly longer than back row so set up front row as a second pile set.

Back row of piles: $L_{\text{back}} = 32 \cdot \text{ft}$

Batter $B_{\text{tr}} = 0.3333$ (3V:1H)

Front row of piles: $L_{\text{front}} = 33.73 \cdot \text{ft}$

Group Interaction

c-c spacing in direction of load: $s_{load} = 7.75 \cdot D$

c-c spacing in direction perpendicular to load: $s_{perp_load} = 7.33 \cdot D$

The C-C spacing in direction of load is almost 8D and since it gets larger with depth due to the batter on the front row, there should be no horizontal group effects.

The C-C spacing in both directions is greater than 3D thus there should be no horizontal or vertical group effects.

Therefore set all group interaction factors to 1.0

Deflection measurement location

See previous design sections for geometry of abutment

The critical point for evaluation of deflections is at the bearing locations which are 17.5 feet above the bottom of the pile cap as modeled. To account for pile cap rotations in the computation of displacement, add a 17.5' tall column to the center of the footing. This is a stick only with nominal properties and sees no load due to the way the problem is modeled.

Results of Analyses

Four runs were made with different combinations of pile head fixity and considering frictional resistance from the soil. These are expected to bracket the extremes of behavior of the pile group. The results of the four runs are summarized in the table below.

The results in Table P-15 are summarized from the FB-Pier Output files

Run #	Units	1	2	3	4
Pile head condition		Fixed	Pinned	Fixed	Pinned
Soil Friction		No	No	Yes	Yes
<u>Strength Limit State</u>					
Maximum Axial load	Kip	340	332	340	332
Pile number and LC		Pile 8 LC1	Pile 8 LC1	Pile 8 LC1	Pile 8 LC1
Maximum Tension	Kip	0.06	1.45	15.3	2.25
Pile number and LC		Pile 7 LC3	Pile 7 LC3	Pile 1 LC3	Pile 13 LC3
Max combined load					
Axial	kip	288	289	336	290
M2	kip-ft	0	0	0	0
M3	kip-ft	107	100	26	97
Pile number and LC		Pile 8 LC3	Pile 8 LC3	Pile 6 LC1	Pile 8 LC3
Depth	FT	8	8	0	8
Max V2	Kips	18.1	18.2	15.9	18.1
Pile number and LC		Pile 7 LC3	Pile 7 LC3	Pile 7 LC3	Pile 7 LC3
Max V3	Kips	3.4	3	3.3	3
Pile number and LC		Pile 2 LC5	Pile 13 LC5	Pile 2 LC5	Pile 13 LC5
<u>Service Limit State</u>					
Max X Displacement	IN	0.481	0.489	0.46	0.474
Max Vertical Displacement	IN	0.133	0.122	0.123	0.108
Load Case		LC6	LC6	LC6	LC6
Max Y displacement	IN	0.02	0.053	0.02	0.053
Load Case		LC6	LC6	LC6	LC6

Table P-15 Results

View of model

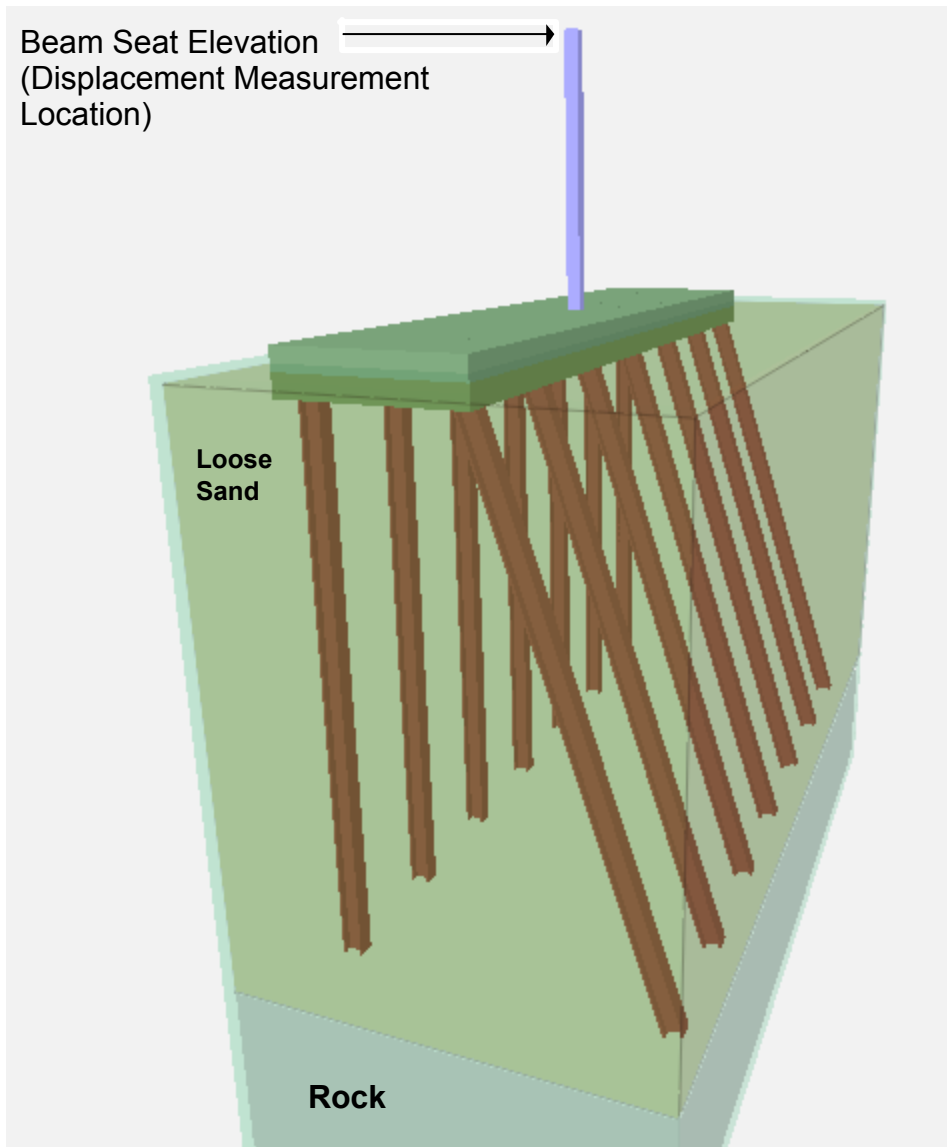

Figure P-14 Model

Design Step P.14 - Check Geotechnical Axial Capacity

From the FB-Pier analyses, and Design Step P.13:

Max factored axial pile load: $P_{\max_a} = 340 \cdot K$

Max factored tension pile load: $P_{\max_t} = 15.3 \cdot K$

These occurred when the pile was assumed to be fully fixed in the pile cap and when soil friction was considered

The maximum factored geotechnical axial resistance, from Design Step P.10 is:

$$Q_r = 340 \cdot K \quad (\text{Controlled by drivability considerations})$$

The ultimate geotechnical tension resistance can be taken as the reverse of what was computed in step P.10 using driven

$$Q_s = 50.39 \cdot K$$

Factored resistance:

$$Q_R = \phi_u \cdot Q_s$$

where:

The ultimate shaft resistance in compression: Q_s

Resistance factor for tension loading: $\phi_u = 0.4$

The computer program Driven employs the Nordlund method to compute shaft friction. No resistance factor is provided for the Nordlund method applied to granular soils but the method is similar to the b method and has similar reliability.

thus:

$$Q_R = \phi_u \cdot Q_s$$

$$Q_R = 20 \cdot K$$

The geotechnical resistance in compression and tension exceeds the maximum factored compressive and tensile pile loads. Thus geotechnical resistance is adequate.

S10.7.3.7.2

S10.5.5-2

S10.5.3

Design Step P.15 - Check Structural Axial Capacity
(in lower portion of pile)

From the FB-Pier analyses, and Design Step P.13:

Max factored axial pile load: $P_{\max_a} = 340 \cdot K$

Max factored tension pile load: $P_{\max_t} = 15.3 \cdot K$

These occurred when the pile was assumed to be fully fixed in the pile cap and when soil friction was considered

The maximum factored structural axial resistance in the lower portion of the pile, from Design Step P.10 is:

$$P_r = 465 K$$

This is also applicable to tension.

The factored structural resistance far exceeds the maximum factored loads. Thus, the piles are adequately sized to transmit axial loads.

Design Step P.16 - Check Structural Axial Capacity in Combined Bending and Axial Load (upper portion of pile)

The equation to use to evaluate combined axial load and bending is determined by the ratio:

$$\frac{P_u}{P_r}$$

S6.9.2.2

where:

Axial compressive load: P_u

Factored compressive resistance: $P_r = \phi_c \cdot P_n$

where:

From Design Step P.10: $P_n = 775K$

For combined axial and bending (undamaged section of pile): $\phi_c = 0.7$

S6.5.4.2

so:

$$P_r = \phi_c \cdot P_n$$

$$P_r = 542.5K$$

From Design Step P.13, maximum combined loadings range from:

$$P_{u_min} = 288 \cdot K \quad \text{to} \quad P_{u_max} = 336 \cdot K$$

so:

$$\frac{P_{u_min}}{P_r} = 0.531 \quad \text{to} \quad \frac{P_{u_max}}{P_r} = 0.619$$

Since these are both greater than 0.2

The combined loading must satisfy:

$$\frac{P_u}{P_r} + \frac{8}{9} \cdot \left(\frac{M_{ux}}{M_{rx}} + \frac{M_{uy}}{M_{ry}} \right) \leq 1.0$$

SEquation
6.9.2.2-2

where:

P_u, P_r are as defined above

Factored flexural moment about the x axis,
from Design Step P.13: M_{ux}

Factored flexural moment about the y axis,
from Design Step P.13: M_{uy}

Factored flexural resistance about the x axis: M_{rx}

Factored flexural resistance about the y axis: M_{ry}

Flexural resistance is:

$$M_r = \phi_f \cdot M_n$$

S6.10.4-1

where:

The resistance factor for combined bending
and axial load in piles: $\phi_f = 1.0$

S6.5.4.2

M_n is computed in accordance with the provisions of Section 6.12.



Deep Foundations Surrounded by Soil

In most cases where deep foundations are completely surrounded by soil, lateral support from even the weakest soil is sufficient such that the unbraced length can be considered zero. When the unbraced length is zero, the buckling considerations of section 6.10.4 generally result in no reduction of the ultimate bending stress and $M_n = \text{the plastic moment or } M_n = f_y \cdot Z$ where Z is the plastic section modulus. Note that the plastic section modulus is used in LRFD design, not the elastic section modulus. The evaluation of buckling criteria on the following pages is presented for completeness.

For bending about the x axis, the provisions of Section 6.10.4 apply as follows:

S6.12.2.2.1

Criteria from Section 6.10.4.1.2:

$$\frac{2 \cdot D_{cp}}{t_w} \leq 3.76 \cdot \left(\frac{E}{F_{yc}} \right)^{0.5}$$

SEquation
6.10.4.1.2-1

for HP 12 x 53 Grade 50 piles:

$$D_{cp} = \frac{d}{2 - t_f} \quad D_{cp} = 5.455 \cdot \text{in}$$

$$\text{From Design Step P.5:} \quad t_w = 0.435 \text{ in}$$

$$\text{Modulus of Elasticity:} \quad E = 29000 \cdot \text{ksi}$$

$$\text{As in Design Step P.10:} \quad F_{yc} = 50 \cdot \text{ksi}$$

Check:

$$\frac{2 \cdot D_{cp}}{t_w} = 25.08 \quad 3.76 \cdot \left(\frac{E}{F_{yc}} \right)^{0.5} = 90.553$$

Therefore:

$$\frac{2 \cdot D_{cp}}{t_w} \leq 3.76 \cdot \left(\frac{E}{F_{yc}} \right)^{0.5} \quad \text{is satisfied.}$$

Criteria from Section 6.10.4.1.3:

$$\frac{b_f}{2 \cdot t_f} \leq 0.382 \cdot \left(\frac{E}{F_{yc}} \right)^{0.5}$$

SEquation
6.10.4.1.3-1

where:

$$b_f = 12.045 \text{ in}$$

$$t_f = 0.435 \text{ in}$$

Check:

$$\frac{b_f}{2 \cdot t_f} = 13.845 \quad 0.382 \cdot \left(\frac{E}{F_{yc}} \right)^{0.5} = 9.2$$

Therefore:

$$\frac{b_f}{2 \cdot t_f} \leq 0.382 \cdot \left(\frac{E}{F_{yc}} \right)^{0.5} \quad \text{NOT SATISFIED}$$

Proceed with criteria of Section 6.10.4.1.4:

Criteria from Section 6.10.4.1.4:

$$\frac{b_f}{2 \cdot t_f} \leq 12$$

Check:

$$\frac{b_f}{2 \cdot t_f} = 13.845 > 12 \quad \text{Condition is NOT SATISFIED}$$

However, this criteria is intended for welded sections to prevent distortion of the flange during welding. Since this is a rolled section, this practical limit does not apply.

S6.10.4.1.4

Therefore proceed to bracing requirements of Section 6.10.4.1.9:

Criteria from Section 6.10.4.1.9:

The pile is laterally braced along its entire length by the adjacent soil thus the unbraced length (L_b) is zero and this condition is always satisfied. S6.10.4.1.9

Proceed to noncompact section flange flexural resistance of Section 6.10.4.2.4

For compression flange:

$$F_n = R_b \cdot R_h \cdot F_{cr}$$

SEquation
6.10.4.2.4a-2

where:

$$F_{cr} = \frac{1.904 \cdot E}{\left(\frac{b_f}{2 \cdot t_f}\right)^2 \cdot \left(\frac{2 \cdot D_{cp}}{t_w}\right)^{0.5}}$$

$$F_{cr} = 57.52 \text{ ksi}$$

but:

$$F_{cr} \text{ cannot exceed } F_{yc} = 50 \text{ ksi}$$

so:

$$F_{cr} = 50 \cdot \text{ksi}$$

and:

Hybrid factor as specified in Section 6.10.4.3.1 for a homogeneous section: $R_h = 1.0$

S6.10.4.3.1a

Load shedding factor specified in Section 6.10.4.3.2: R_b

Check:

$$\frac{2 \cdot D_{cp}}{t_w} \leq \lambda_b \cdot \left(\frac{E}{f_c} \right)^{0.5}$$

SEquation
6.10.4.3.2a-1

where:

$$\text{Since } D_{cp} \leq \frac{d}{2}$$

$$\lambda_b = 5.76$$

Compressive stress in the flange due to factored loads. Since this condition will be critical when f_c is the largest, assume $f_c =$ the maximum possible stress which is the yield stress of the steel.

$$f_c = F_{yc} \quad f_c = 50 \text{ ksi}$$

Check:

$$\frac{2D_{cp}}{t_w} = 25.08$$

$$\lambda_b \cdot \left(\frac{E}{f_c} \right)^{0.5} = 138.719$$

Therefore:

$$\frac{2 \cdot D_{cp}}{t_w} \leq \lambda_b \cdot \left(\frac{E}{f_c} \right)^{0.5} \quad \text{is satisfied}$$

thus:

$$R_b = 1.0$$

so:

$$F_n = R_b \cdot R_h \cdot F_{cr}$$

$$F_n = 50 \text{ ksi}$$

For tension flange:

$$F_n = R_b \cdot R_h \cdot F_{yt}$$

*SEquation
6.10.4.2b-1*

where:

$$R_h = 1$$

$$R_b = 1 \quad \text{for tension flange}$$

S6.10.4.3.2b

$$F_{yt} = 50 \cdot \text{ksi}$$

Therefore:

$$F_n = R_b \cdot R_h \cdot F_{yt}$$

$$F_n = 50 \text{ ksi}$$

Since the nominal plastic stress in all components of the pile is equal to the yield stress, The nominal moment capacity may be computed as the plastic moment.

$$M_n = M_p$$

$$M_p = F_y \cdot Z_x$$

where:

The plastic section modulus about the x axis, $Z_x = 74 \text{ in}^3$
from Design Step P.5:

so:

$$M_{nx} = M_p$$

$$M_p = F_y \cdot Z_x \quad M_p = 3700 \text{ K}\cdot\text{in}$$

$$M_{nx} = 3700 \text{ K}\cdot\text{in}$$

$$M_{nx} = 308.3 \text{ K}\cdot\text{ft}$$

For bending about the y axis, provisions of Section 6.12.2.2.1 apply.

$$M_{ny} = M_p$$

$$M_p = F_y \cdot Z_y$$

$$Z_y = 32.2 \text{ in}^3$$

From Design Step P.5.

$$M_{ny} = F_y \cdot Z_y$$

$$M_{ny} = 1610 \text{ K}\cdot\text{in}$$

$$M_{ny} = 134.2 \text{ K}\cdot\text{ft}$$

SEquation
6.12.2.2.1-1

Check using alternate method from Section C6.12.2.2.1

$$M_{ny} = 1.5 \cdot F_y \cdot S_y$$

CEquation
6.12.2.2.1

where:

The elastic section modulus about the y axis: $S_y = 21.1 \cdot \text{in}^3$

$$M_{ny} = 1.5 \cdot F_y \cdot S_y$$

$$M_{ny} = 1582.5 \text{ K} \cdot \text{in} \quad \text{close to that computed above}$$

Use $M_{ny} = F_y \cdot Z_y \quad M_{ny} = 1610 \text{ K} \cdot \text{in}$

The factored moment resistances are now determined as:

$$M_r = \phi_f \cdot M_n$$

SEquation
6.10.4-1

so:

$$M_{rx} = \phi_f \cdot M_{nx}$$

$$M_{rx} = 308.3 \text{ K} \cdot \text{ft}$$

and:

$$M_{ry} = \phi_f \cdot M_{ny}$$

$$M_{ry} = 134.2 \text{ K} \cdot \text{ft}$$

From the maximum combined loads from Design Step P.13:

The interaction equation is now applied to the maximum combined loading conditions determined in the 4 FB-Pier analyses as follows

$$\frac{P_u}{542.5} + \frac{8}{9} \cdot \left(\frac{M_{ux}}{308.3} + \frac{M_{uy}}{134.2} \right) \leq 1.0$$

SEquation
6.9.2.2-2

FB-Pier Run #	Pu (kips)	Mux (kip-ft)	Muy (kip-ft)	Results of interaction equation
1	288	107	0	0.84
2	289	100	0	0.82
3	336	26	0	0.69
4	290	97	0	0.81

Table P-16 Results of Interaction Equation

All conditions satisfy the interaction equation thus piles are acceptable under combined loading.

Design Step P.17 - Check Structural Shear Capacity**Pile Capacity**

The capacity of the pile section to resist the maximum applied shear force is usually not critical for steel pile sections placed in groups such that high overturning moments are not required to be resisted by the pile. However, in foundation systems consisting of concrete foundation elements arranged as a single element or a single row of elements supporting a tall laterally loaded pier or supporting a column subject to a large eccentric vertical load, this can become the controlling criteria. It is checked here for completeness.

The nominal shear capacity of the pile section is computed as for an unstiffened web of a steel beam.

$$V_n = C \cdot V_p$$

SEquation
6.10.7.2-1

where:

$$V_p = 0.58 \cdot F_{yw} \cdot D \cdot t_w$$

SEquation
6.10.7.2-2

$$F_{yw} = 50 \cdot \text{ksi}$$

From Design Step P.5

$$D = 11.78 \cdot \text{in}$$

$$t_w = 0.435 \cdot \text{in}$$

so:

$$V_p = 0.58 \cdot F_{yw} \cdot D \cdot t_w$$

$$V_p = 148.6 \cdot \text{K}$$

and

C is determined based on criteria in Section 6.10.7.3.3a
with $k = 5$

compute: $\frac{D}{t_w} = 27.08$

compute: $1.1 \cdot \left(\frac{E \cdot k}{F_{yw}} \right)^{0.5}$

$$1.1 \cdot \left(\frac{29000 \cdot 5}{50} \right)^{0.5} = 59.237$$

Check: $27.08 < 59.237$

thus: $C = 1.0$

so:

$$V_n = C \cdot V_p$$

$$V_n = 148.6 \text{ K}$$

Factored resistance: $V_r = \phi_V \cdot V_n$

Resistance factor for shear: $\phi_V = 1.0$

so:

$$V_r = \phi_V \cdot V_n$$

$$V_r = 148.6 \text{ K}$$

From Design Step P.13, the maximum factored shear in any pile in the FB-Pier analysis was 18.2 K.

Thus, piles are acceptable for shear.

SEquation
6.10.7.3.3a-5

S6.5.4.2

**Design Step P.18 - Check Maximum Horizontal and Vertical
Deflection of Pile Group at Beam Seats
Using Service Load Case**

Displacements were determined in the interaction analysis with FB-Pier

It can be seen from the results that the horizontal displacements at the beam seat elevation are slightly higher for the cases of pinned head piles. This is expected and the difference is usually much greater. In this case, the battered piles in the front row resist the majority of the lateral load so pile head fixity is not critical to performance of the foundation system.

From Design Step P.13:

The maximum horizontal deflection observed is $\Delta_h = 0.489 \cdot \text{in}$

The maximum vertical deflection observed is $\Delta_v = 0.133 \cdot \text{in}$

The structural engineer has determined allowable deflections as

The maximum horizontal deflection allowed is $\Delta_{h_all} = 1.5 \cdot \text{in}$ *S10.7.2.2*

The maximum vertical deflection allowed is $\Delta_{v_all} = 0.5 \cdot \text{in}$ *S10.7.2.3.1*

Thus deflections are within tolerances and Service limit states are satisfied. *S10.7.2.4 and S10.7.2.3.1*

Design Step P.19 - Additional Miscellaneous Design Issues**Downdrag**

S10.7.1.4

As indicated in step P.1 elastic settlement of the loose sand will occur after construction of the pile foundation and abutment as the backfill behind the abutment is placed and the approach embankment is constructed.

Compute Settlement for consideration of Downdrag

Figure P-15 shows the location and dimensions of rectangles used to simulate approach embankment loading. The 150' length was arbitrarily selected as representative of the length beyond which additional influence from the approach embankment at the abutment location is not significant. The final approach embankment geometry relative to existing grade may decrease or increase this value. However, use of 150' is considered a reasonable upper bound.

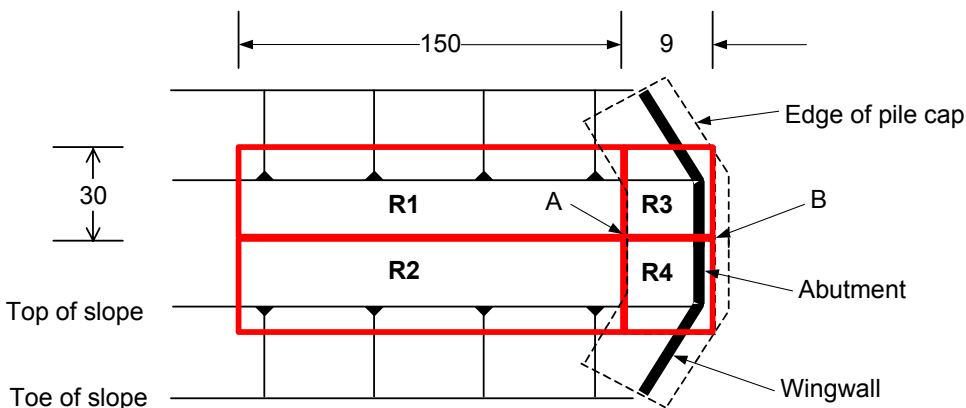

Figure P-15 Plan View of Approach Embankment

Compute settlement at back edge of pile cap (Point A)

$$\text{Depth of layer} = 31 \cdot \text{ft}$$

$$\nu = 0.25$$

$$E_s = 60 \cdot \text{TSF}$$

$$h \text{ of fill} = 21 \cdot \text{ft}$$

$$Y \text{ of fill} = 130 \cdot \text{pcf}$$

$$q_0 = 1.365 \cdot \text{TSF}$$

At point A include influence from R1 and R2

$$B = 30 \cdot \text{ft}$$

$$\frac{L}{B} = 5$$

$$\frac{H}{B} = 1.0333333$$

Note: Influence factors from NAVFAC DM7 are used here because they allow proper consideration of a layer of finite thickness underlain by a rigid base. The influence values in AASHTO assume an infinite elastic halfspace. Also note that the influence values in NAVFAC are for use with a different form of the elastic settlement equation than the one contained in AASHTO. The influence values published in NAVFAC must be used with the settlement equation in NAVFAC as presented below.

From NAVFAC DM7.1-213:

$$I = 0.16 \quad \text{for } \nu = 0.33$$

NAVFAC DM7.1-211:

$$S_{0_R1} = \frac{q_0 \cdot (1 - \nu^2) B \cdot I}{E_s}$$

$$S_{0_R1} = 0.102375 \text{ ft}$$

For two rectangles:

$$S_{0_R1R2} = 2 \cdot S_{0_R1}$$

$$S_{0_R1R2} = 2.457 \text{ in}$$

Compute settlement at front row of piles (Point B)

To simulate this case; the corner of R1 and R2 are shifted forward to be coincident with point B, and the settlement due to the approach fill weight will be equal to that computed for Point A. However, the weight of the approach embankment above the heel of the footing will be supported by the pile foundation and will not contribute to elastic settlement. Thus the settlement at point B can be computed by subtracting the influence of rectangles R3 and R4 from the settlement computed for rectangles R1 and R2 alone.

Contribution of R3 and R4 only

$$B = 9 \cdot \text{ft}$$

$$\frac{L}{B} = 3.333333$$

$$\frac{H}{B} = 3.444444$$

From NAVFAC DM7.1-213

$$I = 0.45 \quad \text{for } \nu = 0.33$$

$$S_{0_R3} = \frac{q_0 \cdot (1 - \nu^2) B \cdot I}{E_s}$$

$$S_{0_R3R4} = 2 \cdot S_{0_R3}$$

$$S_{0_R3R4} = 0.172758 \text{ ft} \quad (\text{for two rectangles})$$

$$R1 + R2 - (R3 + R4) = S_{0_R1R2} - S_{0_R3R4}$$

$$S_{0_R1R2} - S_{0_R3R4} = 0.031992 \text{ ft}$$

$$S_{0_R1R2} - S_{0_R3R4} = 0.383906 \text{ in}$$

This is not sufficient settlement to mobilize downdrag on the front row of piles as per FHWA HI-96-033, Section 9.9.1

Sufficient settlement to mobilize downdrag forces is expected at the back row of piles but not at the front row of piles. This is because the loading producing the settlement is transmitted to the soil starting at the back edge of the footing. Evaluation of downdrag loads is required for the back row of piles but not the front row. Since the back row of piles is lightly loaded and vertical, they can probably handle the downdrag load without any special details. To verify this, the following conservative approach is used.

The maximum possible downdrag force per pile is equal to the ultimate tension capacity computed in step P.14. This conservatively assumes that downdrag is mobilized along the entire length of the pile and is not reduced by the live load portion of the axial load.

$$Q_s = 50.39K$$

Since downdrag is a load, it is factored in accordance with Section 3.4.1-2.

$$\phi_{dd} = 1.8 \quad (\text{maximum})$$

Maximum factored drag load per pile

$$Q_{dd} = \phi_{dd} \cdot Q_s$$

$$Q_{dd} = 90.7K$$

From FB-Pier analysis, the maximum factored Axial load on back row of piles is 23.85 K.

Note: higher loads were observed for service load cases.

If the factored downdrag is added to the maximum observed factored pile load on the back row, the total factored load is:

$$114.4K$$

This is well below the factored resistance computed in Design Step P.10

$$Q = 340K$$

Thus downdrag loads can be safely supported by the back row of piles as designed.

S10.7.1.4
and
C10.7.1.4

STable
3.4.1-2

Battered Piles

S10.7.1.6

This bridge is not in seismic zones 3 or 4 thus battered piles are OK

No downdrag is expected at the front row of piles thus batter of front row is OK

Protection Against Deterioration

S10.7.1.8

Design Step P.1 determined soils and ground water were non corrosive thus no special protection scheme or sacrificial steel is required.

Uplift and Pile to Pile Cap Connection

S10.7.1.9

The FB-Pier analysis showed some of the piles in the back row to be in tension under some of the strength limit states. None of the service limit states showed piles in tension.

**Pile Capacity**

To adequately transfer the tension load from the pile to the pile cap, a special connection detail involving reinforcing passing through a hole in the pile web or shear studs would be normally required.

However, The cases run in FB-Pier that used no skin friction effectively simulate the case of a pile pulling out of the bottom of the footing under tension load. Review of these runs indicate that the pile could be pulled completely out of the bottom of the footing thus design of a tension connection should be included in the design of the pile cap.

From Design Step P.13, the maximum factored tension force is

15.3K

The pile cap connection should be designed to resist this force.

Evaluation of the Pile Group Design

Does Pile Foundation Meet all Applicable Criteria?

Design Steps P.14 through P.19 indicate that all the applicable criteria are met

Is Pile System Optimized?

Determine if the pile system could be improved to reduce cost

Maximum factored axial load is:

$$\frac{P_{\max_a}}{Q_r} = 100\% \text{ of resistance}$$

Maximum factored combined load is:

From Table P.16, the maximum results 84% of resistance of the interaction equation yields:

Some of the front row are not fully loaded due to flexing of the relatively thin pile cap but the front row can be considered optimized.

The back row of piles is severely under utilized for the loads investigated.

However, load cases in which the longitudinal forces are reversed will result in higher loads on the back row of piles. These loads will not exceed the loads on the front row since some longitudinal loads can not be reversed (earth pressure). Still, it may be possible to eliminate every other pile in the back row and still meet all criteria.

A brief evaluation of this possibility using FB-Pier indicates that removing 3 piles from the back row could cause the combined bending and axial stress in the front row of piles to exceed that allowed by the interaction equation. This is because elimination of the piles in the back row causes more of the horizontal loads to be absorbed by the front piles which produces higher bending moments in these piles.

Based on the above, the design is optimized to the greatest extent practical

Summary of Final Design Recommendations

Final Pile Cap Layout

All Piles are HP 12 x 53 Grade 50
 All dimensions shown at bottom of pile cap

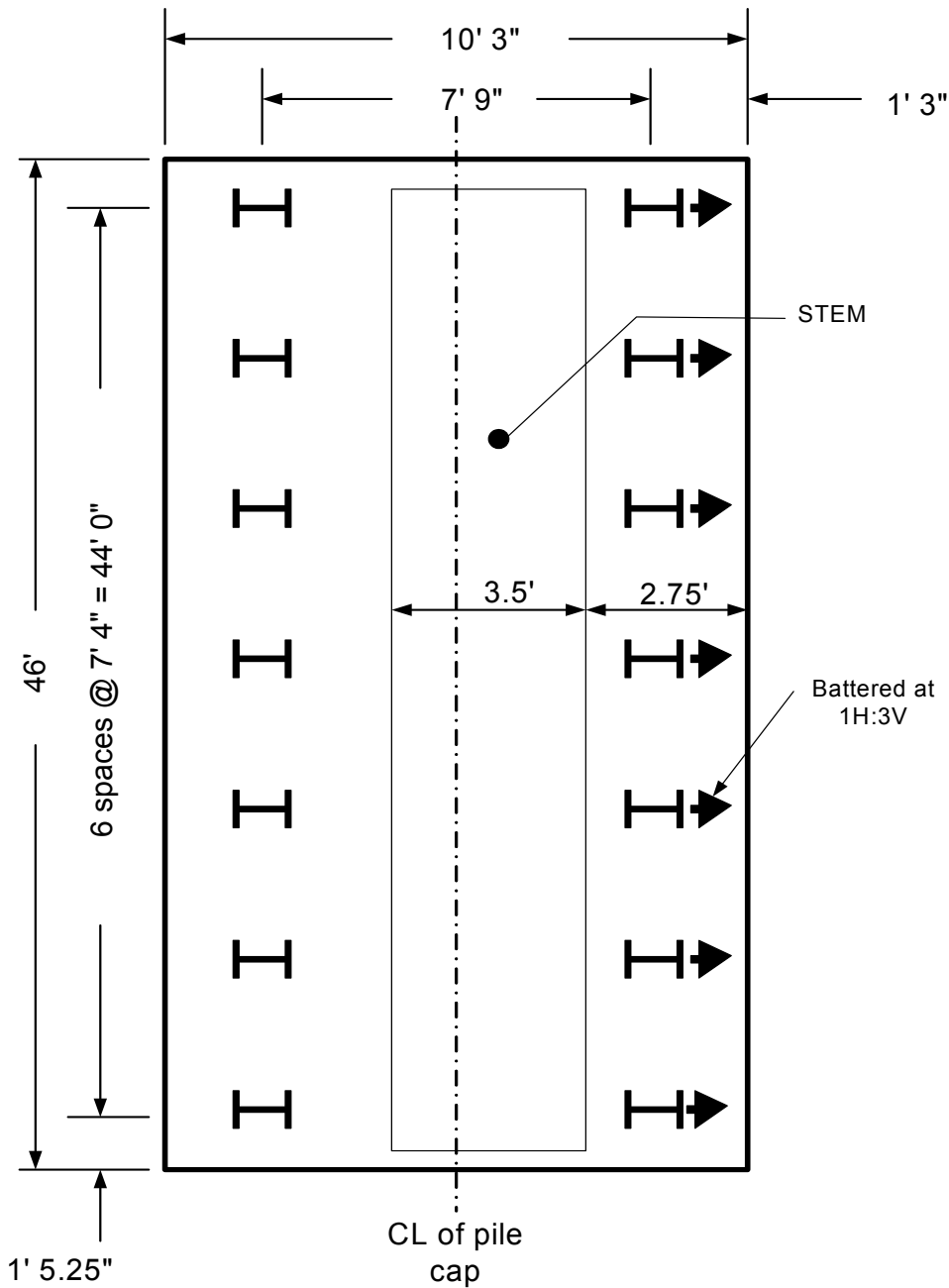

Figure P-16 Final Pile Cap Layout

Design considerations for design of pile cap

Piles to be embedded 1' into pile cap

Piles to have bar through web or shear stud to transfer 15 Kip tension load to cap

For structural design of the cap, the factored axial load per pile is summarized in tables below.

From FB-Pier File FHWA_bat_fix_noskin.out

CASE: Fixed Pile Heads No Skin Friction

FB-Pier Load Case	LC1	LC2	LC3	LC4	LC5	LC6
Limit State	STR-I MAX/FIN	SER-I MAX/FIN	STR-I MIN/FIN	SER-I MIN/FIN	STR-III MAX/FIN	SER-I MAX/FIN
Pile Number						
1	-6.9	-35.0	0.1	-36.1	0.0	-35.0
2	-315.3	-221.5	-273.3	-220.3	-275.2	-221.5
3	-12.7	-40.1	0.1	-41.3	0.0	-40.1
4	-330.5	-232.2	-287.1	-230.9	-284.7	-232.2
5	-15.4	-41.9	0.1	-43.1	0.0	-41.9
6	-336.1	-235.9	-292.4	-234.7	-286.3	-235.9
7	-17.0	-42.8	0.1	-44.0	0.0	-42.8
8	-339.9	-238.6	-292.4	-237.3	-286.2	-238.6
9	-15.3	-40.7	0.1	-41.9	0.0	-40.7
10	-335.4	-234.9	-288.4	-233.7	-279.3	-234.9
11	-12.6	-37.8	0.1	-38.9	0.0	-37.8
12	-330.7	-230.8	-287.8	-229.5	-272.6	-230.8
13	-6.7	-31.3	0.1	-32.4	0.0	-31.3
14	-315.6	-219.3	-274.1	-218.1	-256.4	-219.3

**Table P-17 Factored Axial Load per Pile
Fixed Pile Heads - No Skin Friction**

From FB-Pier File FHWA_bat_pin_noskin.out

CASE: Pinned Pile Heads No Skin Friction

FB-Pier Load Case	LC1	LC2	LC3	LC4	LC5	LC6
Limit State	STR-I MAX/FIN	SER-I MAX/FIN	STR-I MIN/FIN	SER-I MIN/FIN	STR-III MAX/FIN	SER-I MAX/FIN
Pile Number						
1	-13.7	-36.6	1.4	-37.8	-14.6	-36.6
2	-308.4	-219.2	-274.5	-218.0	-254.3	-219.2
3	-19.5	-41.7	1.4	-42.9	-16.8	-41.7
4	-323.8	-230.3	-288.4	-229.0	-267.1	-230.3
5	-22.2	-43.4	1.4	-44.6	-16.7	-43.4
6	-329.5	-234.3	-293.7	-233.1	-271.7	-234.3
7	-23.8	-44.2	1.4	-45.5	-15.8	-44.2
8	-332.2	-237.0	-294.0	-235.7	-272.1	-237.0
9	-22.1	-42.1	1.4	-43.3	-12.4	-42.1
10	-327.8	-233.6	-290.0	-232.4	-268.2	-233.6
11	-19.3	-39.0	1.4	-40.2	-7.9	-39.0
12	-324.3	-230.0	-289.0	-228.7	-266.7	-230.0
13	-13.3	-32.4	1.4	-33.6	-0.8	-32.4
14	-309.1	-218.8	-275.3	-217.5	-253.8	-218.8

**Table P-18 Factored Axial Load per Pile
Pinned Pile Heads - No Skin Friction**

From FB-Pier File FHWA_bat_fix_skin.out

CASE: Fixed Pile Heads Skin Friction

FB-Pier Load Case	LC1	LC2	LC3	LC4	LC5	LC6
Limit State	STR-I MAX/FIN	SER-I MAX/FIN	STR-I MIN/FIN	SER-I MIN/FIN	STR-III MAX/FIN	SER-I MAX/FIN
Pile Number						
1	-5.6	-34.0	15.3	-35.1	-1.6	-34.0
2	-314.5	-220.6	-287.0	-219.4	-271.7	-220.6
3	-11.8	-39.3	14.8	-40.5	-1.4	-39.3
4	-330.3	-231.8	-301.2	-230.5	-282.8	-231.8
5	-14.6	-41.2	14.5	-42.4	0.2	-41.2
6	-336.0	-235.7	-306.4	-234.4	-285.7	-235.7
7	-16.2	-42.2	14.4	-43.4	0.8	-42.2
8	-339.9	-238.4	-309.3	-237.1	-286.7	-238.4
9	-14.5	-40.0	14.5	-41.2	1.8	-40.0
10	-335.3	-234.6	-305.1	-233.4	-280.7	-234.6
11	-11.6	-37.0	14.8	-38.2	2.9	-37.0
12	-330.5	-230.5	-301.4	-229.2	-274.9	-230.5
13	-5.5	-30.3	15.3	-31.4	4.4	-30.3
14	-314.8	-218.5	-287.3	-217.3	-259.3	-218.5

**Table P-19 Factored Axial Load per Pile
Fixed Pile Heads - Skin Friction**

From FB-Pier File FHWA_bat_fix_skin.out

CASE: Pinned Pile Heads Skin Friction

FB-Pier Load Case	LC1	LC2	LC3	LC4	LC5	LC6
Limit State	STR-I MAX/FIN	SER-I MAX/FIN	STR-I MIN/FIN	SER-I MIN/FIN	STR-III MAX/FIN	SER-I MAX/FIN
Pile Number						
1	-13.3	-36.2	2.1	-37.3	-14.3	-36.2
2	-307.5	-218.0	-274.6	-216.8	-254.4	-218.0
3	-19.5	-41.6	1.4	-42.7	-16.7	-41.6
4	-323.5	-229.6	-289.2	-228.3	-267.7	-229.6
5	-22.3	-43.3	1.1	-44.5	-16.7	-43.3
6	-329.4	-233.8	-294.7	-232.5	-272.6	-233.8
7	-23.9	-44.2	0.9	-45.5	-15.9	-44.2
8	-332.0	-236.4	-295.0	-235.1	-273.0	-236.4
9	-22.1	-42.0	1.1	-43.2	-12.5	-42.0
10	-327.4	-232.9	-290.9	-231.6	-268.9	-232.9
11	-19.2	-38.8	1.5	-40.0	-7.9	-38.8
12	-324.0	-229.3	-289.9	-228.0	-267.4	-229.3
13	-13.0	-32.0	2.2	-33.2	-0.7	-32.0
14	-308.2	-217.6	-275.6	-216.3	-253.9	-217.6

**Table P-20 Factored Axial Load per Pile
Pined Pile Heads - Skin Friction**

Absolute maximum from above: 15.319

Absolute minimum from above: -339.9

FB-Pier may be used to print out all stresses in each element of the pile cap as a check on manual methods if desired.

Notes to be placed on Final Drawing

Maximum Factored Axial Pile Load = 340K

Required Factored Axial Resistance = 340K

Piles to be driven to absolute refusal defined as a penetration resistance of 20 Blows Per Inch (BPI) using a hammer and driving system components that produces a driving stress between 37 and 45 KSI at refusal. Driving stress to be estimated using wave equation analysis of the selected hammer.

Verify capacity and driving system performance by performing stress wave measurements on a minimum of 2 piles in each substructure. One test shall be on a vertical pile and the other shall be on a battered pile.

Perform a CAPWAP analysis of each dynamically tested pile. The CAPWAP analysis shall confirm the following:

Driving stress is in the range specified above.

The ultimate pile point capacity (after subtracting modeled skin friction) is greater than:

$$Q_p = 523 \cdot K$$

This is based on a resistance factor (ϕ) of 0.65 for piles tested dynamically.

References:

- | | |
|----------------|--|
| FHWA HI-96-033 | Design and Construction of Driven Pile Foundations, Hannigan, P.J., Gobel, G.G, Thedean, G., Likins, G.E., and Rausche, F. for FHWA, December 1996, Volume 1 and 2 |
| NAVFAC DM7 | Design Manual 7; Volume 1 - Soil Mechanics; Volume 2 - Foundations and Earth Structures, Department of the Navy, Naval Facilities Engineering Command, May 1982. |

PADOT DM4	Design Manual Part 4, Pennsylvania Department of Transportation Publication 15M, April 2000
Reese and Wang (1991)	Unpublished paper presenting group efficiencies of pile groups subject to horizontal loads in different directions and at different spacings.
NCEER-97-0022	Proceedings of the NCEER Workshop on Evaluation of Liquefaction Resistance of Soils, Edited by T.L. Youd, I.M. Idriss. Summary Report, 1997. MCEER Publication NCEER-97-0022

Development of a Comprehensive Design Example for a Steel Girder Bridge with Commentary

Detailed Outline of Steel Girder Design Example

1. General

- 1.1 Obtain design criteria
 - 1.1.1 Governing specifications, codes, and standards
 - 1.1.2 Design methodology
 - 1.1.3 Live load requirements
 - 1.1.4 Bridge width requirement
 - 1.1.4.1 Number of design lanes (in each direction)
 - 1.1.4.2 Shoulder, sidewalk, and parapet requirements
 - 1.1.4.3 Bridge width
 - 1.1.5 Clearance requirements
 - 1.1.5.1 Horizontal clearance
 - 1.1.5.2 Vertical clearance
 - 1.1.6 Bridge length requirements
 - 1.1.7 Material properties
 - 1.1.7.1 Deck concrete
 - 1.1.7.2 Deck reinforcing steel
 - 1.1.7.3 Structural steel
 - 1.1.7.4 Fasteners
 - 1.1.7.5 Substructure concrete
 - 1.1.7.6 Substructure reinforcing steel
 - 1.1.8 Future wearing surface requirements
 - 1.1.9 Load modifiers
 - 1.1.9.1 Ductility
 - 1.1.9.2 Redundancy
 - 1.1.9.3 Operational importance
- 1.2 Obtain geometry requirements
 - 1.2.1 Horizontal geometry
 - 1.2.1.1 Horizontal curve data
 - 1.2.1.2 Horizontal alignment
 - 1.2.2 Vertical geometry
 - 1.2.2.1 Vertical curve data
 - 1.2.2.2 Vertical grades
- 1.3 Span arrangement study
 - 1.3.1 Select bridge type
 - 1.3.2 Determine span arrangement
 - 1.3.3 Determine substructure locations
 - 1.3.3.1 Abutments
 - 1.3.3.2 Piers

- 1.3.4 Compute span lengths
- 1.3.5 Check horizontal clearance requirements
- 1.4 Obtain geotechnical recommendations
 - 1.4.1 Develop proposed boring plan
 - 1.4.2 Obtain boring logs
 - 1.4.3 Obtain foundation type recommendations for all substructures
 - 1.4.3.1 Abutments
 - 1.4.3.2 Piers
 - 1.4.4 Obtain foundation design parameters
 - 1.4.4.1 Allowable bearing pressure
 - 1.4.4.2 Allowable settlement
 - 1.4.4.3 Allowable stability safety factors
 - Overturning
 - Sliding
 - 1.4.4.4 Allowable pile resistance
 - Axial
 - Lateral
- 1.5 Type, Size and Location (TS&L) study
 - 1.5.1 Select steel girder types
 - 1.5.1.1 Composite or noncomposite superstructure
 - 1.5.1.2 Plate girder or roll section
 - 1.5.1.3 Homogeneous or hybrid
 - 1.5.2 Determine girder spacing
 - 1.5.3 Determine approximate girder depth
 - 1.5.4 Check vertical clearance requirements
- 1.6 Plan for bridge aesthetics
 - 1.6.1 Function
 - 1.6.2 Proportion
 - 1.6.3 Harmony
 - 1.6.4 Order and rhythm
 - 1.6.5 Contrast and texture
 - 1.6.6 Light and shadow

2. Concrete Deck Design

- 2.1 Obtain design criteria
 - 2.1.1 Girder spacing
 - 2.1.2 Number of girders
 - 2.1.3 Reinforcing steel cover
 - 2.1.3.1 Top
 - 2.1.3.2 Bottom
 - 2.1.4 Concrete strength
 - 2.1.5 Reinforcing steel strength
 - 2.1.6 Concrete density
 - 2.1.7 Future wearing surface
 - 2.1.8 Concrete parapet properties

- 2.1.8.1 Weight per unit length
- 2.1.8.2 Width
- 2.1.8.3 Center of gravity
- 2.1.9 Design method (assume Strip Method)
- 2.1.10 Applicable load combinations
- 2.1.11 Resistance factors
- 2.2 Determine minimum slab thickness
 - 2.2.1 Assume top flange width
 - 2.2.2 Compute effective span length
- 2.3 Determine minimum overhang thickness
- 2.4 Select thicknesses
 - 2.4.1 Slab
 - 2.4.2 Overhang
- 2.5 Compute dead load effects
 - 2.5.1 Component dead load, DC
 - 2.5.2 Wearing surface dead load, DW
- 2.6 Compute live load effects
 - 2.6.1 Dynamic load allowance
 - 2.6.2 Multiple presence factor
- 2.7 Compute factored positive and negative design moments for each limit state
 - 2.7.1 Service limit states (stress, deformation, and cracking)
 - 2.7.2 Fatigue and fracture limit states (limit cracking)
 - 2.7.3 Strength limit states (strength and stability)
 - 2.7.4 Extreme event limit states (e.g., earthquake, vehicular or vessel collision)
- 2.8 Design for positive flexure in deck
- 2.9 Check for positive flexure cracking under service limit state
- 2.10 Design for negative flexure in deck
- 2.11 Check for negative flexure cracking under service limit state
- 2.12 Design for flexure in deck overhang
 - 2.12.1 Design overhang for horizontal vehicular collision force
 - 2.12.1.1 Check at inside face of parapet
 - 2.12.1.2 Check at design section in overhang
 - 2.12.1.3 Check at design section in first span
 - 2.12.2 Design overhang for vertical collision force
 - 2.12.3 Design overhang for dead load and live load
 - 2.12.3.1 Check at design section in overhang
 - 2.12.3.2 Check at design section in first span
- 2.13 Check for cracking in overhang under service limit state
- 2.14 Compute overhang cut-off length requirement
- 2.15 Compute overhang development length
- 2.16 Design bottom longitudinal distribution reinforcement
- 2.17 Design top longitudinal distribution reinforcement
- 2.18 Design longitudinal reinforcement over piers
- 2.19 Draw schematic of final concrete deck design

3. Steel Girder Design

- 3.1 Obtain design criteria
 - 3.1.1 Span configuration
 - 3.1.2 Girder configuration
 - 3.1.3 Initial spacing of cross frames
 - 3.1.4 Material properties
 - 3.1.5 Deck slab design
 - 3.1.6 Load factors
 - 3.1.7 Resistance factors
 - 3.1.8 Multiple presence factors
- 3.2 Select trial girder section
- 3.3 Compute section properties
 - 3.3.1 Sequence of loading
 - 3.3.2 Effective flange width
 - 3.3.3 Composite or noncomposite
- 3.4 Compute dead load effects
 - 3.4.1 Component dead load, DC
 - 3.4.2 Wearing surface dead load, DW
- 3.5 Compute live load effects
 - 3.5.1 Determine live load distribution for moment and shear
 - 3.5.1.1 Interior girders
 - 3.5.1.2 Exterior girders
 - 3.5.1.3 Skewed bridges
 - 3.5.2 Dynamic load allowance
- 3.6 Combine load effects for each limit state
 - 3.6.1 Service limit states (stress, deformation, and cracking)
 - 3.6.2 Fatigue and fracture limit states (limit cracking)
 - 3.6.3 Strength limit states (strength and stability)
 - 3.6.4 Extreme event limit states (e.g., earthquake, vehicular or vessel collision)
- 3.7 Check section proportions
 - 3.7.1 General proportions
 - 3.7.2 Web slenderness
 - 3.7.3 Flange proportions
- 3.8 Compute plastic moment capacity (for composite section)
- 3.9 Determine if section is compact or noncompact
 - 3.9.1 Check web slenderness
 - 3.9.2 Check compression flange slenderness (negative flexure only)
 - 3.9.3 Check compression flange bracing (negative flexure only)
 - 3.9.4 Check ductility (positive flexure only)
 - 3.9.5 Check plastic forces and neutral axis (positive flexure only)
- 3.10 Design for flexure - strength limit state
 - 3.10.1 Compute design moment
 - 3.10.2 Compute nominal flexural resistance
 - 3.10.3 Flexural stress limits for lateral-torsional buckling
- 3.11 Design for shear (at end panels and at interior panels)
 - 3.11.1 Compute shear resistance

- 3.11.2 Check D_c/t_w for shear
- 3.11.3 Check web fatigue stress
- 3.11.4 Check handling requirements
- 3.11.5 Constructability
- 3.12 Design transverse intermediate stiffeners
 - 3.12.1 Determine required locations
 - 3.12.2 Compute design loads
 - 3.12.3 Select single-plate or double-plate and stiffener sizes
 - 3.12.4 Compute stiffener section properties
 - 3.12.4.1 Projecting width
 - 3.12.4.2 Moment of inertia
 - 3.12.4.3 Area
 - 3.12.5 Check slenderness requirements
 - 3.12.6 Check stiffness requirements
 - 3.12.7 Check strength requirements
- 3.13 Design longitudinal stiffeners
 - 3.13.1 Determine required locations
 - 3.13.2 Compute design loads
 - 3.13.3 Select stiffener sizes
 - 3.13.4 Compute stiffener section properties
 - 3.13.4.1 Projecting width
 - 3.13.4.2 Moment of inertia
 - 3.13.5 Check slenderness requirements
 - 3.13.6 Check stiffness requirements
- 3.14 Design for flexure - fatigue and fracture limit state
 - 3.14.1 Fatigue load
 - 3.14.2 Load-induced fatigue
 - 3.14.2.1 Top flange weld
 - 3.14.2.2 Bottom flange weld
 - 3.14.3 Fatigue requirements for webs
 - 3.14.3.1 Flexure
 - 3.14.3.2 Shear
 - 3.14.4 Distortion induced fatigue
 - 3.14.5 Fracture
- 3.15 Design for flexure - service limit state
 - 3.15.1 Optional live load deflection check
 - 3.15.2 Permanent deflection check
 - 3.15.2.1 Compression flange
 - 3.15.2.2 Tension flange
- 3.16 Design for flexure - constructibility check
 - 3.16.1 Check web slenderness
 - 3.16.2 Check compression flange slenderness
 - 3.16.3 Check compression flange bracing
- 3.17 Check wind effects on girder flanges
- 3.18 Draw schematic of final steel girder design

- 4. Bolted Field Splice Design**
 - 4.1 Obtain design criteria
 - 4.1.1 Splice location
 - 4.1.2 Girder section properties
 - 4.1.3 Material and bolt properties
 - 4.2 Select girder section as basis for field splice design
 - 4.3 Compute flange splice design loads
 - 4.3.1 Girder moments
 - 4.3.2 Strength stresses and forces
 - 4.3.3 Service stresses and forces
 - 4.3.4 Fatigue stresses and forces
 - 4.3.5 Controlling and non-controlling flange
 - 4.3.6 Construction moments and shears
 - 4.4 Design bottom flange splice
 - 4.4.1 Yielding / fracture of splice plates
 - 4.4.2 Block shear rupture resistance
 - 4.4.3 Shear of flange bolts
 - 4.4.4 Slip resistance
 - 4.4.5 Minimum spacing
 - 4.4.6 Maximum spacing for sealing
 - 4.4.7 Maximum pitch for stitch bolts
 - 4.4.8 Edge distance
 - 4.4.9 Bearing at bolt holes
 - 4.4.10 Fatigue of splice plates
 - 4.4.11 Control of permanent deflection
 - 4.5 Design top flange splice
 - 4.5.1 Yielding / fracture of splice plates
 - 4.5.2 Block shear rupture resistance
 - 4.5.3 Shear of flange bolts
 - 4.5.4 Slip resistance
 - 4.5.5 Minimum spacing
 - 4.5.6 Maximum spacing for sealing
 - 4.5.7 Maximum pitch for stitch bolts
 - 4.5.8 Edge distance
 - 4.5.9 Bearing at bolt holes
 - 4.5.10 Fatigue of splice plates
 - 4.5.11 Control of permanent deflection
 - 4.6 Compute web splice design loads
 - 4.6.1 Girder shear forces
 - 4.6.2 Shear resistance for strength
 - 4.6.3 Web moments and horizontal force resultants for strength, service and fatigue
 - 4.7 Design web splice
 - 4.7.1 Bolt shear strength
 - 4.7.2 Shear yielding of splice plate

- 4.7.3 Fracture on the net section
- 4.7.4 Block shear rupture resistance
- 4.7.5 Flexural yielding of splice plates
- 4.7.6 Bearing resistance
- 4.7.7 Fatigue of splice plates
- 4.8 Draw schematic of final bolted field splice design

5. Miscellaneous Steel Design

- 5.1 Design shear connectors
 - 5.1.1 Select studs
 - 5.1.1.1 Stud length
 - 5.1.1.2 Stud diameter
 - 5.1.1.3 Transverse spacing
 - 5.1.1.4 Cover
 - 5.1.1.5 Penetration
 - 5.1.1.6 Pitch
 - 5.1.2 Design for fatigue resistance
 - 5.1.3 Check for strength limit state
 - 5.1.3.1 Positive flexure region
 - 5.1.3.2 Negative flexure region
- 5.2 Design bearing stiffeners
 - 5.2.1 Determine required locations
 - 5.2.2 Compute design loads
 - 5.2.3 Select stiffener sizes and arrangement
 - 5.2.4 Compute stiffener section properties
 - 5.2.4.1 Projecting width
 - 5.2.4.2 Effective section
 - 5.2.5 Check bearing resistance
 - 5.2.6 Check axial resistance
 - 5.2.7 Check slenderness requirements
 - 5.2.8 Check nominal compressive resistance
- 5.3 Design welded connections
 - 5.3.1 Determine required locations
 - 5.3.2 Determine weld type
 - 5.3.3 Compute design loads
 - 5.3.4 Compute factored resistance
 - 5.3.4.1 Tension and compression
 - 5.3.4.2 Shear
 - 5.3.5 Check effective area
 - 5.3.5.1 Required
 - 5.3.5.2 Minimum
 - 5.3.6 Check minimum effective length requirements
- 5.4 Design cross-frames
 - 5.4.1 Obtain required locations and spacing (determined during girder design)
 - 5.4.1.1 Over supports

- 5.4.1.2 Intermediate cross frames
- 5.4.2 Check transfer of lateral wind loads
- 5.4.3 Check stability of girder compression flanges during erection
- 5.4.4 Check distribution of vertical loads applied to structure
- 5.4.5 Design cross frame members
- 5.4.6 Design connections
- 5.5 Design lateral bracing
 - 5.5.1 Check transfer of lateral wind loads
 - 5.5.2 Check control of deformation during erection and placement of deck
 - 5.5.3 Design bracing members
 - 5.5.4 Design connections
- 5.6 Compute girder camber
 - 5.6.1 Compute camber due to dead load
 - 5.6.1.1 Dead load of structural steel
 - 5.6.1.2 Dead load of concrete deck
 - 5.6.1.3 Superimposed dead load
 - 5.6.2 Compute camber due to vertical profile of bridge
 - 5.6.3 Compute residual camber (if any)
 - 5.6.4 Compute total camber

6. Bearing Design

- 6.1 Obtain design criteria
 - 6.1.1 Movement
 - 6.1.1.1 Longitudinal
 - 6.1.1.2 Transverse
 - 6.1.2 Rotation
 - 6.1.2.1 Longitudinal
 - 6.1.2.2 Transverse
 - 6.1.2.3 Vertical
 - 6.1.3 Loads
 - 6.1.3.1 Longitudinal
 - 6.1.3.2 Transverse
 - 6.1.3.3 Vertical
- 6.2 Select optimum bearing type (assume steel-reinforced elastomeric bearing)
- 6.3 Select preliminary bearing properties
 - 6.3.1 Pad length
 - 6.3.2 Pad width
 - 6.3.3 Thickness of elastomeric layers
 - 6.3.4 Number of steel reinforcement layers
 - 6.3.5 Thickness of steel reinforcement layers
 - 6.3.6 Edge distance
 - 6.3.7 Material properties
- 6.4 Select design method
 - 6.4.1 Design Method A
 - 6.4.2 Design Method B

- 6.5 Compute shape factor
- 6.6 Check compressive stress
- 6.7 Check compressive deflection
- 6.8 Check shear deformation
- 6.9 Check rotation or combined compression and rotation
 - 6.9.1 Check rotation for Design Method A
 - 6.9.2 Check combined compression and rotation for Design Method B
- 6.10 Check stability
- 6.11 Check reinforcement
- 6.12 Check for anchorage or seismic provisions
 - 6.12.1 Check for anchorage for Design Method A
 - 6.12.2 Check for seismic provisions for Design Method B
- 6.13 Design anchorage for fixed bearings
- 6.14 Draw schematic of final bearing design

7. Abutment and Wingwall Design

- 7.1 Obtain design criteria
 - 7.1.1 Concrete strength
 - 7.1.2 Concrete density
 - 7.1.3 Reinforcing steel strength
 - 7.1.4 Superstructure information
 - 7.1.5 Span information
 - 7.1.6 Required abutment height
 - 7.1.7 Load information
- 7.2 Select optimum abutment type (assume reinforced concrete cantilever abutment)
 - 7.2.1 Cantilever
 - 7.2.2 Gravity
 - 7.2.3 Counterfort
 - 7.2.4 Mechanically-stabilized earth
 - 7.2.5 Stub, semi-stub, or shelf
 - 7.2.6 Open or spill-through
 - 7.2.7 Integral
 - 7.2.8 Semi-integral
- 7.3 Select preliminary abutment dimensions
- 7.4 Compute dead load effects
 - 7.4.1 Dead load reactions from superstructure
 - 7.4.1.1 Component dead load, DC
 - 7.4.1.2 Wearing surface dead load, DW
 - 7.4.2 Abutment stem dead load
 - 7.4.3 Abutment footing dead load
- 7.5 Compute live load effects
 - 7.5.1 Placement of live load in longitudinal direction
 - 7.5.2 Placement of live load in transverse direction
- 7.6 Compute other load effects
 - 7.6.1 Vehicular braking force

- 7.6.2 Wind loads
 - 7.6.2.1 Wind on live load
 - 7.6.2.2 Wind on superstructure
- 7.6.3 Earthquake loads
- 7.6.4 Earth pressure
- 7.6.5 Live load surcharge
- 7.6.6 Temperature loads
- 7.7 Analyze and combine force effects for each limit state
 - 7.7.1 Service limit states (stress, deformation, and cracking)
 - 7.7.2 Fatigue and fracture limit states (limit cracking)
 - 7.7.3 Strength limit states (strength and stability)
 - 7.7.4 Extreme event limit states (e.g., earthquake, vehicular or vessel collision)
- 7.8 Check stability and safety requirements
 - 7.8.1 Check pile group stability and safety criteria (if applicable)
 - 7.8.1.1 Overall stability
 - 7.8.1.2 Axial pile resistance
 - 7.8.1.3 Lateral pile resistance
 - 7.8.1.4 Overturning
 - 7.8.1.5 Uplift
 - 7.8.2 Check spread footing stability and safety criteria (if applicable)
 - 7.8.2.1 Maximum bearing pressure
 - 7.8.2.2 Minimum bearing pressure (uplift)
 - 7.8.2.3 Overturning
 - 7.8.2.4 Sliding
 - 7.8.2.5 Settlement
- 7.9 Design abutment backwall
 - 7.9.1 Design for flexure
 - 7.9.1.1 Design moments
 - 7.9.1.2 Flexural resistance
 - 7.9.1.3 Required reinforcing steel
 - 7.9.2 Check for shear
 - 7.9.3 Check crack control
- 7.10 Design abutment stem
 - 7.10.1 Design for flexure
 - 7.10.1.1 Design moments
 - 7.10.1.2 Flexural resistance
 - 7.10.1.3 Required reinforcing steel
 - 7.10.2 Check for shear
 - 7.10.3 Check crack control
- 7.11 Design abutment footing
 - 7.11.1 Design for flexure
 - 7.11.1.1 Minimum steel
 - 7.11.1.2 Required steel
 - 7.11.2 Design for shear
 - 7.11.2.1 Concrete shear resistance
 - 7.11.2.2 Required shear reinforcement

- 7.11.3 Check crack control
- 7.12 Draw schematic of final abutment design

8. Pier Design

- 8.1 Obtain design criteria
 - 8.1.1 Concrete strength
 - 8.1.2 Concrete density
 - 8.1.3 Reinforcing steel strength
 - 8.1.4 Superstructure information
 - 8.1.5 Span information
 - 8.1.6 Required pier height
- 8.2 Select optimum pier type (assume reinforced concrete hammerhead pier)
 - 8.2.1 Hammerhead
 - 8.2.2 Multi-column
 - 8.2.3 Wall type
 - 8.2.4 Pile bent
 - 8.2.5 Single column
- 8.3 Select preliminary pier dimensions
- 8.4 Compute dead load effects
 - 8.4.1 Dead load reactions from superstructure
 - 8.4.1.1 Component dead load, DC
 - 8.4.1.2 Wearing surface dead load, DW
 - 8.4.2 Pier cap dead load
 - 8.4.3 Pier column dead load
 - 8.4.4 Pier footing dead load
- 8.5 Compute live load effects
 - 8.5.1 Placement of live load in longitudinal direction
 - 8.5.2 Placement of live load in transverse direction
- 8.6 Compute other load effects
 - 8.6.1 Centrifugal force
 - 8.6.2 Vehicular braking force
 - 8.6.3 Vehicular collision force
 - 8.6.4 Water loads
 - 8.6.5 Wind loads
 - 8.6.5.1 Wind on live load
 - 8.6.5.2 Wind on superstructure
 - 8.6.5.3 Wind on pier
 - 8.6.6 Ice loads
 - 8.6.7 Earthquake loads
 - 8.6.8 Earth pressure
 - 8.6.9 Temperature loads
 - 8.6.10 Vessel collision
- 8.7 Analyze and combine force effects for each limit state
 - 8.7.1 Service limit states (stress, deformation, and cracking)
 - 8.7.2 Fatigue and fracture limit states (limit cracking)

- 8.7.3 Strength limit states (strength and stability)
- 8.7.4 Extreme event limit states (e.g., earthquake, vehicular or vessel collision)
- 8.8 Design pier cap
 - 8.8.1 Design for flexure
 - 8.8.1.1 Maximum design moment
 - 8.8.1.2 Cap beam section properties
 - 8.8.1.3 Flexural resistance
 - 8.8.2 Design for shear and torsion
 - 8.8.2.1 Maximum design values
 - Shear
 - Torsion
 - 8.8.2.2 Cap beam section properties
 - 8.8.2.3 Required area of stirrups
 - For torsion
 - For shear
 - Combined requirements
 - 8.8.2.4 Longitudinal torsion reinforcement
 - 8.8.3 Check crack control
- 8.9 Design pier column
 - 8.9.1 Slenderness considerations
 - 8.9.2 Interaction of axial and moment resistance
 - 8.9.3 Design for shear
- 8.10 Design pier piles
- 8.11 Design pier footing
 - 8.11.1 Design for flexure
 - 8.11.1.1 Minimum steel
 - 8.11.1.2 Required steel
 - 8.11.2 Design for shear
 - 8.11.2.1 Concrete shear resistance
 - 8.11.2.2 Required reinforcing steel for shear
 - 8.11.2.3 One-way shear
 - 8.11.2.4 Two-way shear
 - 8.11.3 Check crack control
- 8.12 Draw schematic of final pier design

9. Miscellaneous Design

- 9.1 Design approach slabs
- 9.2 Design bridge deck drainage
- 9.3 Design bridge lighting
- 9.4 Check for bridge constructability
- 9.5 Complete additional design considerations

10. Special Provisions and Cost Estimate

- 10.1 Develop special provisions

- 10.1.1 Develop list of required special provisions
- 10.1.2 Obtain standard special provisions from client
- 10.1.3 Develop remaining special provisions
- 10.2 Compute estimated construction cost
 - 10.2.1 Obtain list of item numbers and item descriptions from client
 - 10.2.2 Develop list of project items
 - 10.2.3 Compute estimated quantities
 - 10.2.4 Determine estimated unit prices
 - 10.2.5 Determine contingency percentage
 - 10.2.6 Compute estimated total construction cost

P. Pile Foundation Design

- P.1 Define subsurface conditions and any geometric constraints
- P.2 Determine applicable loads and load combinations
- P.3 Factor loads for each combination
- P.4 Verify need for a pile foundation
- P.5 Select suitable pile type and size based on factored loads and subsurface conditions
- P.6 Determine nominal axial structural resistance for selected pile type and size
- P.7 Determine nominal axial geotechnical resistance for selected pile type and size
- P.8 Determine factored axial structural resistance for single pile
- P.9 Determine factored axial geotechnical resistance for single pile
- P.10 Check driveability of pile
- P.11 Do preliminary pile layout based on factored loads and overturning moments
- P.12 Evaluate pile head fixity
- P.13 Perform pile soil interaction analysis
- P.14 Check geotechnical axial capacity
- P.15 Check structural axial capacity
- P.16 Check structural capacity in combined bending and axial
- P.17 Check structural shear capacity
- P.18 Check maximum horizontal and vertical deflection of pile group
- P.19 Additional miscellaneous design issues